



COWLEY HALL SCIENCE BUILDING

PROGRAM STATEMENT & PRE-DESIGN STUDY

University of Wisconsin – La Crosse
La Crosse, Wisconsin
DSF Project No. 09J2H

Prepared By:
River Architects, Inc.
La Crosse, Wisconsin

August 2011

Approved By:

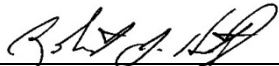
Agency Representative:  Date: August 24, 2011
Robert J. Hetzel

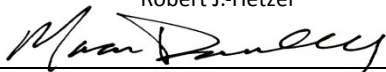
UW-System Representative:  Date: August 15, 2011
Maura Donnelly

A/E Consultant Representative:  Date: August 24, 2011
Valentine J. Schute, Jr.

Table of Contents

Acknowledgements	2
Division 1: Executive Summary	3
Division 2: Building Program	7
2.1 Approach	7
2.2 Objectives and Assumptions – Classroom Programming	7
2.3 Classroom Mix Study	7
2.4 Program Space Allocation	7
2.5 Occupants/Users and Activities	8
2.6 Building Program Summary/Space Tabulation	10
2.7 Graphic Space Analysis	20
2.8 Sample Room Layouts	27
Division 3: Physical Planning Issues	41
3.1 Site/Existing Conditions	41
3.2 Civil Utilities and Plan	45
3.3 Transportation/Circulation	47
3.4 Existing Building Assessment	50
Division 4: Special Planning Issues	65
4.1 Environmental Impact	65
4.2 Zoning Requirements	65
4.3 Accessibility Requirements	65
4.4 Sustainable Facilities and Energy Conservation	66
4.5 Commissioning	72
4.6 Hazardous Substances	72
4.7 Equipment	73
Division 5: Pre-Design Concept	75
5.1 Overview	75
5.2 Approach	75
5.3 Phased Building Program	75
5.4 Design Guidelines/Assumptions	84
5.5 Pre-Design Site Plan Concept	85
5.6 Building Massing and Functional Layout Diagrams	89
5.7 Laboratory Systems	112
5.8 Architectural Systems	132
5.9 Structural Systems	136
5.10 Fire Protection Systems	138
5.11 Plumbing Systems	140
5.12 Mechanical Systems	145
5.13 Electrical Systems	154
5.14 Telecommunications Systems	162
Division 6: Code Review	165
Division 7: Project Cost Estimate	171
Division 8: Schedule	175
Appendices:	
Appendix A: Room Data Sheets	
Appendix B: University of Wisconsin – La Crosse Cowley Hall Science Building Program Space Allocation	

Acknowledgements

University of Wisconsin – La Crosse

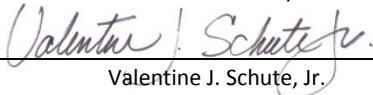
Joe Gow
Chancellor

Kathleen Enz Finken
Provost and Vice Chancellor for Academic Affairs

Robert Hetzel
Vice Chancellor for Administration & Finance

Matt Lewis
Executive Director Facilities Planning & Management

Bruce Riley
College of Science & Health – Interim Dean

Bob Hoar
Faculty Assistant to the Provost

David Howard
Department Chair - Biology

Aaron Monte
Department Chair – Chemistry

Cynthia Berlin
Department Chair – Geography & Earth Science

David Koster
Department Chair – Mathematics

S. N. Rajagopal
Department Chair – Microbiology

Gubbi Sudhakaran
Department Chair – Physics

Jeff Bryan
Radiation Center

Shelly Leshner
Radiation Center

Kurt Grunwald
Radiation Center

Mark Sandheinrich
Director – River Studies Center

Thomas Greiner
Anatomy

University of Wisconsin – System Administration

Maura Donnelly
Senior Facilities Architect

**State of Wisconsin –
Department of Administration
Division of State Facilities**

Jeff Plale
Division Administrator

Gil Funk
Director, Bureau of Architecture & Engineering

Larry Earll/Beth Reid
Project Management

Document Prepared By:

River Architects, Inc.
Architectural Design & Planning
La Crosse, WI

Paulien & Associates, Inc.
Facilities and Space Analysis
Denver, CO

Research Facilities Design
Laboratory Design & Planning
San Diego, CA

Henneman Engineering, Inc.
*Structural, Mechanical, and
Electrical Engineering and Sustainability*
Madison, WI

JJR, LLC
Civil Engineering and Landscape Design
Madison, WI

Division 1: Executive Summary

Introduction

The Cowley Hall Science Building project described in this document is the result of a collaborative effort between the State of Wisconsin Department of Administration-Division of State Facilities, University of Wisconsin System Administration, the University of Wisconsin-La Crosse and the Pre-Design Team with the goal of providing a Program Statement and Pre-Design Study. The Pre-Design Team was strategically assembled by River Architects to engage experts in their respective fields to work together on this science building. The program initiative was lead by Paulien & Associates, while Research Facilities Design (RFD) contributed the expertise in science facility planning. Site analysis and design was conducted by JJR and the overall engineering work was prepared by Henneman Engineering.

Project Scope

This project will construct new space to accommodate the academic programs in the physical and life sciences at the University of Wisconsin-La Crosse. The increased demand for access to the allied health professions programs at UW-L has resulted in greatly increased demand for basic courses in the physical and life sciences. In addition, instruction in the sciences is also required by other degree programs at the university. As such, the large demand for courses in the basic sciences results in greatly increased pressure on the existing laboratory facilities. This intense use of the facilities, coupled with the fact that Cowley Hall, the university's science building, was constructed over forty-five years ago, is making it increasingly problematic to deliver quality instruction.

Also, an increased emphasis on undergraduate and faculty research has put additional strains on the laboratory facilities. These spaces and the aged building infrastructure that supports them are not in adequate condition to accommodate the level or the intensity of use that is required of them.

New space is needed for instructional laboratories, research activities, faculty offices and delivery of general science instruction. The campus Master Plan currently acknowledges a large block of space being added to existing Cowley Hall, with the old laboratory and classroom portion of the building being renovated, and the office wing on the west side of the building being removed. However, one of the tasks of the Pre-Design Report will be to provide a cost benefit analysis of salvaging the existing laboratory and classroom portion of the building versus demolishing the entire existing facility and construction of all new space.

The project site is currently occupied by existing Cowley Hall and a 180 stall parking lot. Surrounding buildings include Murphy Library and Resource Center to the west, Centennial Hall and Hoeschler Clock Tower to the southwest, Wittich Hall to the south, the campus Central Plant to the southeast, and Wimberly Hall to the northwest. A new Student Union is being planned for construction directly to the north of Cowley Hall.

Approach

The Pre-Design Team presented a collaborative process to involve the entire project team in the discovery process. The meetings were systematically scheduled to develop the needs for the Program Statement, assess the physical condition of the existing facility, evaluate the site opportunities and Master Plan directives, develop design options, and prepare project cost estimates for committee review. The meetings were conducted over a fourteen month period and progressed from the detailed definition of the Program Statement to the development of a viable design option for the Study.

Building Program

The development of the Program Statement was a team effort with River Architects leading, Paulien & Associates adding their higher education programming expertise, and Research Facilities Design focusing on the science laboratories spaces. The overall objective was to provide the science programs with an adequate amount of space to conduct the activities required in each type of space represented in the building program. To the degree possible, space efficiencies, including sharing of certain spaces like conference rooms, core laboratory service spaces, and storage were explored and are reflected in the program. A classroom mix analysis was not conducted as part of the scope of services. Rather the outcome of the 2007 Campuswide Classroom Mix Study prepared by Paulien & Associates was used with some modifications to determine classroom needs.

For the science programs included in the building program, it is anticipated that there will be undergraduate student growth of three percent (3%) by 2015 and an overall growth of five percent (5%) by 2020. No growth in graduate students is expected. The teaching laboratories are meeting the University of Wisconsin System utilization goal of 19.2 hours per seat. Because the use of the existing laboratories is very strong with the occupancy rates being very good, there is little room for student growth. This is why more laboratories are needed than currently exist.

Division 1: Executive Summary

Due to UW-La Crosse’s commitment to grant funded faculty and undergraduate student research, there is a very strong need for additional research space. UW-La Crosse at \$2.9 million, has 54% more sponsored research activity than the average of its IPED’s peer list. This research space is assigned to each faculty member, and it is assumed that it will be shared with assigned students. The arrangement and size of research lab space is unique to each discipline.

The 27% shortage of office space in the existing Cowley Hall is primarily due to space limitations, and results in shared offices or being located in other buildings on campus. When you factor office needs for graduate and teaching assistants, the deficit in the number of office spaces increases to 50%.

The table below summarizes the program space allocation by unit and then by space type. A total of 208,149 Assignable (Net Usable) Square Feet has been programmed which includes: 13 classrooms and 40 laboratories; the College of Science and Health Dean’s suite; the departments of Biology, Chemistry, Geography & Earth Science, Mathematics, Microbiology, Physics, Radiation Center, River Studies Center and building support spaces.

Program Summary by Unit and Space Use Type

Unit	Classroom Space (100s)	Teaching Laboratory Space (210s)	Open Laboratory Space (220s)	Research Laboratory Space (250s)	Office Space (300s)	Other Departmental Space (400s - 700s)	Student Lounge and Dining (630 and 650)	Faculty Support (650)	Building Support	TOTAL AREA	Percent of Total
1 • Classrooms	21,800									21,800	10%
2 • Misc. Instructional/Support Spaces		3,240	3,844		5,121	3,040	2,350	1,280		18,875	9%
3 • Biology Department		19,200	480	13,200	8,498	8,330				49,708	24%
4 • Chemistry Department		24,160	1,320	6,600	4,496	360				36,936	18%
5 • Geography & Earth Science		6,880		2,640	1,808	360				11,688	6%
6 • Mathematics Department		3,200		720	4,988	1,215				10,123	5%
7 • Microbiology Department		10,240		5,760	3,403	360				19,763	9%
8 • Physics Department		5,760	3,680	5,440	1,902	3,840				20,622	10%
9 • Radiation Center			2,720	2,560	120					5,400	3%
10 • River Studies Center				3,520						3,520	2%
11 • College of Science and Health – Dean’s Office					1,994					1,994	1%
12 • Building Support						1,740			5,980	7,720	4%
TOTAL AREA	21,800	72,680	12,044	40,440	32,330	19,245	2,350	1,280	5,980	208,149	100%
Percent of Total	10%	35%	6%	19%	16%	9%	1%	1%	3%	100%	

The building program is primarily comprised of instructional space (51%), research space (19%), and offices (16%). Approximately eleven percent (11%) of the building is other academic support space (such as vivarium, herbarium, greenhouse, planetarium, specimen space, and resource spaces), student lounge and dining services, and faculty support spaces.

Existing Building Assessment

Cowley Hall was originally constructed in 1963 and had two primary additions to the north and east in 1968. Numerous classroom, laboratory, and mechanical renovations have occurred over the past 48 years, but haven’t changed the original 1963-68 footprint. The 180,000 square foot, shaped four story building has a full basement and fifth floor mechanical penthouse. The assessment of the facility condition is summarized by components as follows:

- **STRUCTURE**
 - The cast in place concrete structure appears to be in good condition and has marginal loading capacity. The floor-to-floor height of 12’-0” severely limits renovation potential for many laboratory and classroom uses.

- **ENVELOPE**
 - The exterior walls have no thermal insulation and do not meet DSF standards for flashing and rain-screen cavity walls. The curtain wall and window glazing system is original construction and has non-thermally broken frames with ¼” glazing and allows water to infiltrate during storm events. The roof was replaced in 2002 with a 45 mil EPDM membrane over 5 1/2” of insulation board and is in good condition.

- **MECHANICAL/ELECTRICAL**
 - The engineering system infrastructure is well beyond their useful life expectations and needs to be replaced.

Overall, the building’s structural frame is the best system component for reuse, with the caveat that the floor-to-floor height constraints will severely limit many proposed uses. The envelope deficiencies can be remedied, but will require careful detail analysis and the improvements may be cost prohibitive.

Division 1: Executive Summary

Pre-Design Concept

The development of the design response for the project was influenced by the needs outlined in the Program Statement, the requirement that the existing facility stay in use until the new building is complete, and the cost to provide a new 327,522 GSF science facility. The study team accepted the premise of the need for a phased implementation approach to divide the project into the manageable phases. The decision to focus on the teaching, open, and research laboratories in Phase 1 equates to 107,880 ASF, or approximately 179,800 GSF of new construction that would then connect to the existing building until Phase 2 is started. Phase 2 would provide the balance of the program needs, including classrooms, collaborative learning spaces, conference rooms, faculty offices, and other ancillary departmental spaces in 93,065 ASF, or approximately 147,722 GSF of new or combination of new and renovated space.

The study's design scheme positions the Phase 1 work on the northern parking lot in a T plan configuration that connects to the middle of the existing building. The facility is 4 stories above grade at 16 feet floor-to-floor with a basement and mechanical penthouse. The new addition to existing building connection matches the first floor level height and then uses a new stair tower and elevator to connect the differing floor heights at levels 2 through 4 to ease the vertical circulation challenges.

The floor plan on each level is a loop configuration with a single loaded corridor to the north and a double loaded corridor at the south. This arrangement positions the modular laboratories back-to-back for layout and venting flexibility. The exit stairs are positioned at the east (service) and west (Mall) entrances and at the south where the new building links to the existing building. The two new elevators are located at the southern linkage to the existing building and in the southeastern corner to align with the east first floor service entrance. The departmental distribution of the laboratories positions the Radiation Center in the basement for shielding, Physics on the first floor for vibration control, Biology on the second floor, Microbiology on the third floor, and Chemistry on the fourth floor.

Phase 2 has two options for consideration. A new addition that replaces the existing Cowley Hall building or a combination of a renovated 1963 center wing with a new addition to the east. The west office wing will remain in both options for interim office use until Phase 2 is ready for occupancy and will then be demolished. Both options will include the classrooms, collaborative learning spaces, departments, offices, conference rooms, and ancillary support spaces to complete the program needs.

Both Phase 2 options use a central double loaded corridor scheme oriented east-west to maximize the area available for the large classrooms. The upper floors use a loop circulation plan with offices positioned on the perimeter to maximize the natural light opportunities. The vertical circulation is deliberately positioned at the east (service) and west (Mall) ends at the entrances to simplify wayfinding. The departments are distributed to align with their laboratory functions as space permits on each level, and they are never separated more than one level.

The final design configuration positions an H shape plan with two formal entrances and a courtyard facing west on the proposed central mall to strategically anchor the northeast quadrant on this important campus Master Plan element. The east facing courtyard on East Avenue is screened and serves as a limited parking and service area for the complex.

The overall 208,695 ASF/340,325 GSF plan addresses the numerous campus planning issues outlined in the Campus Master Plan and delivers a modular laboratory layout for teaching efficiency and future flexibility.

Project Cost

The estimated project cost for Phase 1 is \$79,452,100. The Phase 2 option for a new facility is \$54,986,350 and the option with renovation of the 1963 original building and a new addition to the east is \$60,124,800. The cost estimates are adjusted for inflation to the projected start dates of construction.

Recommendation

This Study recommends that Phase 2 focuses on the new facility option and demolishes the existing Cowley Hall building. The excessive renovation costs and the inability to match the floor levels with Phase 1 severely limit the existing building's renovation potential and because ceiling heights will be compromised, renovation of the existing building will result in a project that won't fully meet the requirements of the building program. The combination of Phase 1 and a new facility Phase 2 option delivers a state-of-the-art science facility that is programmed for flexibility to meet decades of intensive science use.

Division 1: Executive Summary

Executive Summary Overview

Project Scope:

Create adequate, modern-day space for instructional laboratories, research facilities, faculty offices, and delivery of general science education.

Project Phasing:

Because the budget for Phase 1 was set, UW-La Crosse administration determined it would be in the best interest of the University to assign as many teaching, research, and open laboratory spaces as possible to Phase 1, while keeping existing office and classroom space operational in existing Cowley Hall and in doing so, some spaces were allocated to Phase 2 but are preferred to be in Phase 1.

<u>Phase</u>	<u>Total Area ASF/GSF</u>	<u>Estimated Cost</u>
Phase 1:	107,670 ASF/179,800 GSF	\$79,452,100
Phase 2:	93,065 ASF/147,722 GSF	\$50-60,000,000

Project Budget:

The University of Wisconsin-System Administration has set the project budget for Phase 1 at \$80,000,000. The budget for Phase 2 was undecided at the time this report was written, but the outcome of this report has an estimated value between 50 and 60 million dollars.

Project Schedule:

Begin design of Phase 1	September 2013
Bidding of Phase 1	February 2015
Occupancy of Phase 1	Fall 2017

Although a definitive schedule for Phase 2 is unknown at this time, UW-La Crosse would prefer the Phase 2 work begin immediately following Phase 1.

Project Issues:

UW-La Crosse and UW-System Administration have determined that a new chiller plant or renovations to the existing central plant will need to occur prior to the completion of Phase 1. This work is to be separate from the Cowley Hall project.

Division of State Facilities has indicated that the existing lecture halls in Cowley Hall be universally accessible providing access to each level within the lecture hall. Due to an increase in the number of sections taught, along with the requirement for universal access, the result is a need to construct new lecture hall space. Since the existing building footprint and structural bay spacing won't support the sizes of lecture halls currently programmed, demolition of the existing east wing and construction of a new addition was agreed upon to be the best approach in a renovation/new addition scenario. If reuse of the existing Cowley Hall is deemed unfeasible as recommended in this report, the new lecture halls will be integrated into Phase 2 as appropriate.

The existing west wing of Cowley Hall currently serves as the office space for the building. This wing will need to remain in use until the completion of Phase 2.

Phase 1 will need to include a connecting link that will allow access to the floors of both the new laboratory facility as well as the existing Cowley Hall.

The existing Cowley Hall, built in 1963 has numerous issues that need to be addressed if the facility is to be reused. Issues related to water infiltration during rain events, envelope thermal performance, structural floor heights, outdated mechanical systems, non ADA compliance, outdated finishes, and other factors all influence the recommendation to demolish existing Cowley Hall and reconstruct a new facility.

Division 2: Building Program

2.1 Approach

In March 2010, River Architects, Inc. along with Paulien & Associates and Research Facilities Design (RFD) were commissioned by the Division of State Facilities to provide the Building Program and Pre-Design services for the University of Wisconsin – La Crosse’s Cowley Hall Science Building. This report consists of three primary objectives – building program, pre-design concept design, and existing building assessment. The Building Program will focus on the needs of the project and allocate square footages accordingly. The Pre-Design will test fit these square footages and graphically represent a possible design solution.

The first meeting, held in April 2010, was to familiarize the user groups with current trends in science facility design at other institutions across the country. RFD presented a modular laboratory design concept which offers flexibility for future needs.

The intent of the second meeting, held in May 2010, was to collect data from each user group to determine the programming needs for the building with a primary focus on space needs outside of the teaching laboratories.

A detailed workshop held in June 2010 focused on the equipment and spacial needs of the teaching laboratories, research areas, and other departmental support spaces.

The fourth programming meeting held in July 2010 focused on the first draft of the Building Program space needs. Departments reviewed and revised their area requirements in depth and a final draft of the Building Program was developed.

2.2 Objectives and Assumptions – Classroom Programming

The consultants and University of Wisconsin La Crosse representatives outlined the planning strategies to be used in this analysis. A classroom mix analysis was not conducted for this project, but rather the outcomes of the 2007 Campuswide Classroom Mix Analysis were used with some modifications to determine classroom needs.

2.3 Classroom Mix Study

Review of Existing Facilities

The consultants toured a number of classrooms across campus that showed little to no scheduled use and recommended reclassifying those spaces so that the room use codes reflect the actual usage of the rooms. A list of these spaces was submitted to the Office of Facilities Management during the course of the 2007 study. The consultants adjusted the inventory used in the study to reflect the changes.

Right Size Existing Classrooms

The existing inventory of type “A” classrooms and type “B” classrooms were reviewed as part of the 2007 Classroom Mix Analysis. An important outcome of the analysis directed the construction of the New Academic Building in order to allow for the removal of a significant percentage of the type “B” classrooms from the classroom mix on the UW-L campus. Another outcome was to allow for the right-sizing of all type A classrooms to 25 assignable square feet (ASF) per student station with the exception of fixed seat classrooms.

Recommendation

The final program statement recommends construction of 13 classrooms in the Cowley Hall Science Building. These classrooms are recommended to vary in size from 24 seats to 150 seats.

2.4 Program Space Allocation

Building Program Development

Work sessions were held with the UW-La Crosse Planning Committee, Department Chairs and faculty of the departments that were chosen to be included in the Cowley Hall Science Building. These work sessions reviewed the initial program documentation and updated the program to reflect current thinking and projected needs for these individual units upon occupancy of the Cowley Hall Science Building. Units included in the program include Biology, Chemistry, Geography & Earth Science, Mathematics, Microbiology, Physics, River Studies Center, Radiation Center and the College of Science and Health – Dean’s Office. The Cowley Hall Science Building is projected to contain 200,945 ASF of space.

2.5 Occupants/Users and Activities

Classrooms

Classrooms programmed to be in the Cowley Hall Science Building range in size from 24 seats to 150 seats. Each classroom should be carefully designed to accommodate a maximum depth to width aspect ratio of 1:1.5 and shall provide proper viewing angles to the presentation wall. Seating types may include table and chairs as well as tablet arm chairs. It is desired by the University to use fixed tables and movable chairs in the 120 and 150 seat classrooms.

Technology levels as per the UW-System standards should be a minimum of Level 3+, which includes a marker board, projection screen, overhead projector, lighting fixtures switched in groups and controlled by electronic touch-screen control, darkening shades, voice and data connections, podium, VCR, DVD or Bluray player, CD player, sound system, and computer.

Miscellaneous Instructional/Support Spaces

Spaces allocated as Miscellaneous Instructional/Support Spaces are those that provide additional resources for learning and collaboration outside of the classroom. These include a cyber café, faculty resource center, student collaborative learning spaces, conference rooms, and vending areas. Collaborative learning spaces may include open lounge areas, enclosed quiet study spaces, or enclosed group study areas equipped with technology. UW-La Crosse prefers these functions to be dispersed on all levels of the building rather than concentrated on one level.

Biology Department

The Biology Department offers a Bachelor of Science in Biology with a concentration in five primary areas; General Biology, Biomedical Science, Cellular and Molecular Biology, Aquatic Science, and Environmental Science. In addition, a graduate program provides the opportunity for a Master of Science in Biology with several specialties. Biology currently serves over 700 majors and consists of over 20 faculty and academic staff.

Chemistry Department

The Chemistry Department offers a Bachelor of Science in Chemistry and Biochemistry with a strong effort to providing a broad-based education that seeks to develop problem-solving skills through challenging coursework and hands-on laboratory experiences with modern equipment, instrumentation, and computation. Chemistry currently serves over 250 majors and each year, approximately 20 students graduate with Bachelor's degrees, of which 30-50% apply to, and are accepted by, graduate programs in major research universities.

Geography & Earth Science

Since the department founding in 1909, the mission has focused on promoting geographical awareness and environmental literacy through classroom activities, research projects, and outreach programs. In addition to stimulating classroom discussions led by the faculty, students gain extensive hands-on experience using the latest GIS and remote sensing software, GPS, and many other geographic and earth science tools.

UW-La Crosse's geographical location and proximity to the Mississippi River, towering limestone bluffs, and a 900 acre urban wetland, provide an abundance of opportunities for student projects, research, and exploration.

Mathematics Department

The Mathematics Department currently consists of twenty-five teacher-scholars who are dedicated to excellence in undergraduate education. In addition to the teaching program, department members are engaged in a variety of scholarship, research, and professional service activities, including traditional research-scholarship, support for undergraduate mathematics research programs, participation in national mathematics organizations, and outreach in middle/high school mathematics. Research interests within the department include algebra, fluid dynamics, graph theory, harmonic analysis, mathematical biology, mathematics education, numerical analysis, operator theory, and statistics.

Microbiology Department

The Microbiology Department offers four different curricular tracks in the undergraduate microbiology major, and two MS concentrations. The Clinical Laboratory Science major is also included in Microbiology, and provides employment opportunities using skills of microbiology and chemistry to make clinical diagnoses. UW-La Crosse sets itself apart from other comprehensive universities by having a major in Microbiology.

Division 2: Building Program

Physics Department

The Physics Department offers both a Bachelor of Science degree in Physics and a dual degree in Physics/Engineering. In addition, the Department features emphases in special areas: Astronomy, Optics, and Computational Physics, as well as physics degrees with Business or Biomedical Concentrations.

The Physics Department has a strong emphasis on undergraduate research. Students typically work with a faculty member on a research project in their specialty area. This mode of instruction gives students hands-on learning opportunities which are very different from the traditional classroom experience.

Radiation Center

The Radiation Center is a multi-discipline facility with two primary uses - laboratory space used for instructional support in the sciences and research space or research support space that supports faculty members from Chemistry and Physics.

River Studies Center

The River Studies Center is a non-curricular unit focusing on research and informational programs pertinent to the Upper Mississippi River and its related resources. During the past 30 years, the River Studies Center has expanded its research program to other aquatic resources, including rivers, streams, lakes, and wetlands across Wisconsin, the Upper Midwest, and the Nation.

College of Science and Health – Dean's Office

The primary focus of the College of Science and Health is to provide an education in the diverse discipline of science, health, and mathematics. The College is dedicated to student learning where enthusiastic faculty and staff intellectually challenge students in a supportive and professional environment.

Building Support

Building Support has been identified as spaces typically included in the net to gross factor of a building. These spaces will be critical as they serve as primary functional space needed for the operation of the building. Spaces assigned to Building Support include arrival space, general building storage, equipment and supply storage, IT storage and work room spaces, custodial rooms, loading and temporary storage, recycling areas, and gender neutral restrooms. The programmed ASF of these spaces has been determined during the program development process and should be taken into careful consideration during the design phase.

Division 2: Building Program

2.6 Building Program Summary

<u>UNIT</u>	<u>DESCRIPTION</u>	<u>TOTAL ASF</u>	<u>% of TOTAL</u>
1	General Access Classrooms	21,800	10.8%
2	Miscellaneous Instructional/Support Spaces	18,881	9.4%
3	Biology	50,188	25.0%
4	Chemistry	36,936	18.4%
5	Geography & Earth Science	11,688	5.8%
6	Mathematics	10,123	5.0%
7	Microbiology	19,763	9.8%
8	Physics	20,622	10.3%
9	Radiation Center	5,400	2.8%
10	River Studies Center	3,520	1.7%
11	College of Science and Health – Dean’s Office	2,024	1.0%
12	<i>Building Support (Non-Assignable)</i>	<i>7,720</i>	<i>0%</i>
TOTAL ASF		200,945	100%

Division 2: Building Program

UNIT NO.	UNIT	NO. OF OCC.	ASF / OCC	ASF / SPACE	NO. OF SPACES	TOTAL ASF	TOTAL AREA
1	Classrooms						
1A	24 Seat Classroom	24	25	600	2	1,200	
1B	32 Seat Classroom	32	25	800	3	2,400	
1C	40 Seat Classroom	40	25	1,000	1	1,000	
1D	48 Seat Classroom	48	25	1,200	3	3,600	
1E	120 Seat Classroom *	120	24	2,880	2	5,760	
1F	150 Seat Classroom *	150	24	3,600	2	7,200	
1G	Classroom Support – Lecture Prep Storage			320	2	640	
	<i>* Style of seating and size of room TBD</i>						21,800
2	Miscellaneous Instructional/Support Spaces						
2A	Science Education Methods Laboratory						
2A1	Lab Area	40	45	1,800	1	1,800	
2A2	Prep Area and Storage (Share with Math Ed Labs)			320	1	320	
2B	Building Laboratory Support						
2B1	Dark Room			160	1	160	
2B2	Dry Chemical Storage			800	1	800	
2B3	Acid Storage			160	1	160	
2C	Student Collaborative Learning Spaces			3,364	1	3,364	
2D	Testing Room(s)	2	60	120	4	480	
2E	Office Suite Circulation			2,727	1	2,727	
2F	Conference Room	20	30	600	4	2,400	
2G	Shared Printing Areas			80	4	320	
2H	Chemical Waste Holding			160	1	160	
2I	Field Equipment Storage			1,280	1	1,280	
2J	Shop			1,280	1	1,280	
2K	Faculty Resource Center	20	32	640	2	1,280	
2L	Vending & Seating Area			450	3	1,350	
2M	Cyber Café					1,000	
	<i>Vending/Food Cart</i>			100	1	100	
	<i>Seating</i>	30	30	900	1	900	
							18,881
3	Biology						
3A	Department Chair's Office	1	120	120	1	120	
3B	Ranked Faculty Office	1	120	120	22	2,640	
3C	Future Ranked Faculty Office	1	120	120	7	840	
3D	Lecturer – Full Time	1	120	120	5	600	
3E	Lecturer – Part Time	2	60	120	1	120	
3F	Support Staff/Reception Area/Files					458	
	<i>Academic Department Associate</i>	1	80	80	1	80	
	<i>Future Office Staff</i>	1	80	80	1	80	

Division 2: Building Program

UNIT NO.	UNIT	NO. OF OCC.	ASF / OCC	ASF / SPACE	NO. OF SPACES	TOTAL ASF	TOTAL AREA
	<i>Student Workers</i>	1	35	35	2	70	
	<i>Reception Area</i>	6	25	150	1	150	
	<i>Storage Cabinets</i>	2	6	12	1	12	
	<i>Lateral Files</i>	6	11	66	1	66	
3G	Secure Office Storage (4 storage cabinets)	1	120	120	1	120	
3H	Workroom			120	2	240	
3I	Teaching Assistants	2	60	120	8	960	
3J	Graduate Students	2	60	120	17	2,040	
3K	Lab Support Staff	1	120	120	3	360	
3L	Introductory Biology Laboratory	28	46	1,280	3	3,840	
3M	Anatomy/Physiology Laboratory (includes ESS)	24	53	1,280	3	3,840	
3N	Aquatics Laboratory	20	64	1,280	1	1,280	
3O	Animal/Organizimal Laboratory	24	53	1,280	1	1,280	
3P	Botany Laboratory (adjacent to Greenhouse)	24	53	1,280	1	1,280	
3Q	Cell Laboratory	20	64	1,280	1	1,280	
3R	Genetics Laboratory	20	64	1,280	1	1,280	
3S	Laboratory Support						
3S1	Anatomy/Physiology Prep. & Cadaver Storage			1,280	1	1,280	
3S2	Introductory Biology/Aquatics Prep/Storage			320	2	640	
3S3	Animal/Organizimal & Botany Prep/Storage			640	1	640	
3S4	Cell Genetics Preparation/Autoclave			960	1	960	
3S5	Core Microscope Suite			960	1	960	
3S6	PCR Suite – shared with Microbiology			320	1	320	
3S7	Cold Room			320	1	320	
3T	Biology Special Projects Laboratory	10	48	480	1	480	
3U	Faculty/Student Research (large paired lab)	3	480	1,440	7	10,080	
3V	Faculty/Student Research (paired lab)	2	320	640	3	1,920	
3W	Environmental Sample Processing Room			1,280	1	1,280	
3X	Environmental Chamber Room			400	1	400	
3Y	Vivarium						
3Y1	Animal Rooms	1	120	120	8	960	
3Y2	Procedures Room	1	480	480	2	960	
3Y3	Cage Wash	1	320	320	1	320	
3Y4	Storage	1	160	160	2	320	
3Y5	Dirty Room	1	160	160	1	160	
3Y6	Lab Manager	1	120	120	1	120	
3Z	Herbarium	1	960	960	1	960	
3AA	Greenhouse						
3AA1	Greenhouse	1	960	960	1	960	
3AA2	Headhouse	1	160	160	1	160	

Division 2: Building Program

UNIT NO.	UNIT	NO. OF OCC.	ASF / OCC	ASF / SPACE	NO. OF SPACES	TOTAL ASF	TOTAL AREA
3AA3	Aquatics Space	1	160	160	1	160	
3AA4	Isolation Space	1	320	320	2	640	
3AB	Specimen Museum						
3AB1	Display Specimen	1	640	640	1	640	
3AB2	Specimen Non-Display	1	320	320	2	640	
3AB3	Office Area	1	60	60	1	60	
3AB4	Rock Collection			160	1	160	
3AB5	Table and Chairs	30	25	750	1	750	
3AC	General Lab/Departmental Storage			120	3	360	
							50,188
4	Chemistry						
4A	Department Chair's Office	1	120	120	1	120	
4B	Ranked Faculty Office	1	120	120	16	1,920	
4C	Future Ranked Faculty Office	1	120	120	1	120	
4D	Lecturer – Full Time	1	120	120	9	1,080	
4E	Lecturer – Part Time	1	60	60	2	120	
4F	Support Staff/Reception Area/Files					446	
	<i>Academic Department Associate</i>	1	80	80	1	80	
	<i>Future Support Staff</i>	1	80	80	1	80	
	<i>Student Workers</i>	1	35	35	2	70	
	<i>Reception Area</i>	6	25	150	1	150	
	<i>Lateral Files</i>	6	11	66	1	66	
4G	Workroom			120	1	120	
4H	Secure Storage (1 storage; 3 file cabinets)	1	120	120	1	120	
4I	Lab Support Staff	1	120	120	2	240	
4J	Student Workers	6	35	210	1	210	
4K	General Chemistry I Laboratory	24	53	1,280	3	3,840	
4L	General Chemistry II Laboratory	24	53	1,280	2	2,560	
4M	Biochemistry Laboratory	24	53	1,280	2	2,560	
4N	Survey of Organic Chemistry Laboratory	24	53	1,280	1	1,280	
4O	Organic Chemistry Majors Laboratory	24	53	1,280	2	2,560	
4P	Analytical Chemistry Laboratory	24	53	1,280	2	2,560	
4Q	Instrumental Chemistry Laboratory	12	107	1,280	1	1,280	
4R	Physical Chemistry Laboratory	24	53	1,280	1	1,280	
4S	Laboratory Support						
4S1	General Chemistry Prep/Balance			640	1	640	
4S2	General/Survey of Organic Prep/Balance			640	1	640	
4S3	General Chemistry II Prep/Balance			640	1	640	
4S4	Biochemistry Prep/Equipment			640	1	640	
4S5	Organic Chemistry Majors Prep/Equipment			640	1	640	

Division 2: Building Program

UNIT NO.	UNIT	NO. OF OCC.	ASF / OCC	ASF / SPACE	NO. OF SPACES	TOTAL ASF	TOTAL AREA
4S6	Analytical Chemistry Prep/Balance			640	1	640	
4S7	Instrumental /Physical Chemistry Prep/Balance			640	1	640	
4S8	NMR (should be in basement)			480	1	480	
4S9	Stock Dispensing			960	1	960	
4S10	Flammable Storage			320	1	320	
4T	Chemical Analysis Computer Lab	24	35	840	1	840	
4U	Computerized Instrument. Lab (computational)	12	40	480	1	480	
4V	Faculty/Student Research (standard)						
4V1	Faculty/Student Research – Biochemistry	1	400	400	4	1,600	
4V2	Faculty/Student Research – Synthesis	1	400	400	6	2,400	
4V3	Faculty/Student Research – Analytical	1	400	400	3	1,200	
4V4	Faculty/Student Research – Chemistry Education	1	400	400	1	400	
4V5	Faculty/Student Research – Physical/Instrumental	1	400	400	2	800	
4W	Faculty/Student Research (computational)	1	200	200	1	200	
4X	General Lab/Departmental Storage			120	3	360	
							36,936
5	Geography & Earth Science						
5A	Department Chair's Office	1	120	120	1	120	
5B	Ranked Faculty Office	1	120	120	7	840	
5C	Future Ranked Faculty Office	1	120	120	2	240	
5D	Lab Support Staff	1	120	120	1	120	
5E	Support Staff/Reception Area/Files					248	
	<i>Academic Department Associate</i>	<i>1</i>	<i>80</i>	<i>80</i>	<i>1</i>	<i>80</i>	
	<i>Student Workers</i>	<i>1</i>	<i>35</i>	<i>35</i>	<i>1</i>	<i>35</i>	
	<i>Reception Area</i>	<i>4</i>	<i>25</i>	<i>100</i>	<i>1</i>	<i>100</i>	
	<i>Lateral Files</i>	<i>3</i>	<i>11</i>	<i>33</i>	<i>1</i>	<i>33</i>	
5F	Office Storage			120	1	120	
5G	Workroom			120	1	120	
5H	Earth Science Laboratory	30	43	1,280	1	1,280	
5I	Geomorphology & Weather Laboratory	30	43	1,280	1	1,280	
5J	Introductory GIS Laboratory	30	43	1,280	1	1,280	
5K	Advanced GIS Laboratory						
5K1	Main Laboratory	36	44	1,600	1	1,600	
5K2	Server Room			160	1	160	
5L	Laboratory Support						
5L1	Earth Science Prep Storage			320	1	320	
5L2	Geomorphology Prep Storage			320	1	320	
5L3	Geography Storage			480	1	480	
5L4	Cold Room			160	1	160	
5M	Faculty/Student Research (standard)	1	400	400	5	2,000	

Division 2: Building Program

UNIT NO.	UNIT	NO. OF OCC.	ASF / OCC	ASF / SPACE	NO. OF SPACES	TOTAL ASF	TOTAL AREA
5N	Faculty/Student Research (computational)	1	160	160	4	640	
5O	General Lab/Departmental Storage			120	3	360	
							11,688
6	Mathematics						
6A	Department Chair's Office	1	120	120	1	120	
6B	Ranked Faculty Office	1	120	120	24	2,880	
6C	Future Ranked Faculty Office	1	120	120	3	360	
6D	Lecturer – Full Time	1	120	120	5	600	
6E	Lecturer – Part Time	1	60	60	2	120	
6F	Lab Support Staff	1	120	120	1	120	
6G	Support Staff/Reception Area/Files					428	
	<i>Academic Department Associate</i>	1	80	80	1	80	
	<i>Future Office Staff</i>	1	80	80	1	80	
	<i>Student Workers</i>	1	35	35	1	35	
	<i>Reception Area</i>	8	25	200	1	200	
	<i>Lateral Files (lockable, secure)</i>	3	11	33	1	33	
6H	Graduate Students	2	60	120	1	120	
6I	Workroom			120	1	120	
6J	Office Storage			120	1	120	
6K	Laboratory – Math Education Space	40	40	1,600	2	3,200	
6L	Math Research Team Rooms/Collaboratorium	8	30	240	3	720	
6M	Undergraduate Research/Library					1,095	
	<i>Bookshelves</i>	20	4	80	1	80	
	<i>Comfortable Seating</i>	6	40	240	1	240	
	<i>Computer Stations</i>	1	35	35	5	175	
	<i>Tables and Chairs</i>	1	30	30	20	600	
6N	General Lab/Departmental Storage			120	1	120	
							10,123
7	Microbiology						
7A	Department Chair's Office	1	120	120	1	120	
7B	Ranked Faculty Office	1	120	120	6	720	
7C	Future Ranked Faculty Office	1	120	120	1	120	
7D	Lecturer – Full Time	1	120	120	5	600	
7E	Support Staff/Reception Area/Files					283	
	<i>Academic Department Associate</i>	1	80	80	1	80	
	<i>Student Workers</i>	1	35	35	2	70	
	<i>Reception Area</i>	4	25	100	1	100	
	<i>Lateral Files</i>	3	11	33	1	33	
7F	Graduate Assistants/Students	2	60	120	9	1,080	
7G	Office Storage			120	1	120	

Division 2: Building Program

UNIT NO.	UNIT	NO. OF OCC.	ASF / OCC	ASF / SPACE	NO. OF SPACES	TOTAL ASF	TOTAL AREA
7H	Lab Support Staff	1	120	120	3	360	
7I	Fundamental Microbiology Laboratory	20	64	1,280	1	1,280	
7J	Pathogenic Bacteriology/Medical Mycology Lab	24	53	1,280	1	1,280	
7K	Bacterial Physiology/Genetics/Microbial Ecology	24	53	1,280	1	1,280	
7L	Gen Ed/Food Microbiology/Nutrition Laboratory	24	53	1,280	1	1,280	
7M	Immunology/Virology Laboratory	24	53	1,280	1	1,280	
7N	Laboratory Support						
7N1	Gen Microbiology Prep/Autoclave			1,600	1	1,600	
7N2	Tissue Culture			320	1	320	
7N3	Centrifuge Room			480	1	480	
7N4	Fermentation Lab			800	1	800	
7N5	Cold Room			160	1	160	
7N6	Equipment/Instrumentation Room and Storage			480	1	480	
7O	Faculty/Student Research (large)						
7O1	Faculty/Student Research - Virology	1	960	960	1	960	
7O2	Faculty/Student Research – Pathogenic	1	960	960	1	960	
7O3	Faculty/Student Research – Genetics	1	960	960	1	960	
7P	Faculty/Student Research (medium)						
7P1	Faculty/Student Research – Immunology	1	640	640	1	640	
7P2	Faculty/Student Research – Bacterial Physiology	1	640	640	1	640	
7P3	Faculty/Student Research – Microbial Ecology	1	640	640	1	640	
7Q	Faculty/Student Research (standard)						
7Q1	Faculty/Student Research – Microbiology	1	480	480	1	480	
7Q2	Faculty/Student Research – Food Microbiology	1	480	480	1	480	
7R	General Lab/Departmental Storage			120	3	360	
							19,763
8	Physics						
8A	Department Chair's Office	1	120	120	1	120	
8B	Ranked Faculty Office	1	120	120	7	840	
8C	Future Ranked Faculty Office	1	120	120	1	120	
8D	Lecturer – Part Time	2	60	120	1	120	
8E	Support Staff/Reception Area/Files					237	
	<i>Academic Department Associate</i>	1	80	80	1	80	
	<i>Student Workers</i>	1	35	35	1	35	
	<i>Reception Area</i>	4	25	100	1	100	
	<i>Lateral Files</i>	2	11	22	1	22	
8F	Workroom			120	1	120	
8G	Office Storage			120	1	120	
8H	Lab Support Staff	1	120	120	1	120	
8I	Student Workers (Lab Prep)	1	35	35	3	105	

Division 2: Building Program

UNIT NO.	UNIT	NO. OF OCC.	ASF / OCC	ASF / SPACE	NO. OF SPACES	TOTAL ASF	TOTAL AREA
8J	Introductory Physics Laboratory	30	64	1,920	1	1,920	
8K	Electronics/Astronomy Laboratory	30	43	1,280	1	1,280	
8L	Studio Lab	24	53	1,280	1	1,280	
8M	Laboratory Support						
8M1	Introductory Prep & Storage			320	1	320	
8M2	Electronics Prep & Storage			320	1	320	
8M3	Studio Prep & Storage			640	1	640	
8N	Holography Laboratory	6	53	320	1	320	
8O	Optics Laboratory	24	40	960	1	960	
8P	Advanced/Experimental Physics Laboratory	24	53	1,280	1	1,280	
8Q	Laboratory Support						
8Q1	Optics Prep & Storage			320	1	320	
8Q2	Advanced Prep & Storage			320	1	320	
8R	Computational Computer Lab	12	40	480	1	480	
8S	Faculty/Student Research (x-large)	1	1,280	1,280	2	2,560	
8T	Faculty/Student Research (Theorists)	3	320	960	1	960	
8U	Faculty/Student Research (Experimentalists)	1	640	640	3	1,920	
8V	Planetarium						
8V1	Planetarium (two-story space)	70	15	1,050	1	1,050	
9V2	Storage	1	120	120	2	240	
8V3	Prefunction/Welcome Area	1	500	500	1	500	
8V4	Display Cases	10	4	40	1	40	
8W	Rooftop Observatory						
8W1	Telescopes	6	60	360	1	360	
8W2	Observation Platform	50	15	750	1	750	
8W3	Waiting Area	20	15	300	1	300	
8W4	Storage	1	120	120	1	120	
8X	General Lab/Departmental Storage			120	2	240	
8Y	Student Organization Space	2	60	120	2	240	
							20,622
9	Radiation Center						
9A	Director/Safety Officer	1	120	120	1	120	
9B	Sealed Source Laboratory	24	53	1,280	1	1,280	
9C	Open Source Laboratory	24	53	1,280	1	1,280	
9D	Laboratory Support – Stock Room			160	1	160	
9E	Shared Isotope Prep	1	400	400	1	400	
9F	Faculty/Student Research (Chemistry)	1	400	400	1	400	
9G	Faculty/Student Research (Physics)	1	1,280	1,280	1	1,280	
9H	Laboratory Support						
9H1	Special Instruments			267	1	267	

Division 2: Building Program

UNIT NO.	UNIT	NO. OF OCC.	ASF / OCC	ASF / SPACE	NO. OF SPACES	TOTAL ASF	TOTAL AREA
9H2	Nuclide Storage			160	1	160	
9H3	Neutron Howitzer			53	1	53	
							5,400
10	River Studies Center						
10A	Faculty/Student Research Wet Lab	1	1,440	1,440	1	1,440	
10B	Class 100 Clean Research Lab	1	320	320	1	320	
10C	Faculty Student Research	1	1,440	1,440	1	1,440	
10D	Laboratory Support						
10D1	Microscope – 11			160	1	160	
10D2	Fish Culture – 42D			160	1	160	
							3,520
11	College of Science and Health – Dean’s Office						
11A	Dean’s Office	1	185	185	1	185	
11B	Associate Dean’s Office	1	145	145	1	145	
11C	Assistant to Dean’s Office	1	135	135	1	135	
11D	Dean’s Assistant	1	135	135	1	135	
11E	Assistant to Dean	1	135	135	1	135	
11F	Support Staff/Reception Area/Files					449	
	<i>Academic Department Associate</i>	1	80	80	1	80	
	<i>Student Workers</i>	1	120	120	1	120	
	<i>Reception Area</i>	6	25	150	1	150	
	<i>Lateral Files</i>	9	11	99	1	99	
11G	Workroom			120	1	120	
11H	Conference Room	12	30	360	1	360	
11I	Storage	1	120	120	1	120	
11J	Grad Assistant/Advisor	1	120	120	1	120	
11K	Administrative Specialist	1	120	120	1	120	
							2,024
12	Building Support						
12A	Arrival Space Primary			1,500	1	1,500	
12B	Arrival Space Secondary			900	2	1,800	
12C	Equipment Storage			500	1	500	
12D	Supply Storage			400	1	400	
12E	Custodial Maintenance Room			200	1	200	
12F	Loading Dock			320	1	320	
12G	Temporary Storage			640	1	640	
12H	Building Recycling Collection Area			200	1	200	
12I	Recycling Area (two per floor)			25	8	200	
12J	IT & Electrical Closets			100	16	1,600	
12K	Sustainability Support Space			0	0	0	

Division 2: Building Program

UNIT NO.	UNIT	NO. OF OCC.	ASF / OCC	ASF / SPACE	NO. OF SPACES	TOTAL ASF	TOTAL AREA
12L	Custodial Closets			100	8	800	
12M	IT Storage/Workroom			200	1	200	
12N	Uni-Sex Restrooms	1	70	70	8	560	
Total Non-Assignable Space							8,920
(Non-assignable space not included in total ASF)							
TOTAL ASSIGNABLE SQUARE FEET (ASF)							200,945

Division 2: Building Program

2.7 Graphic Space Analysis

Unit 1: Classrooms

Total Area: 21,800 ASF

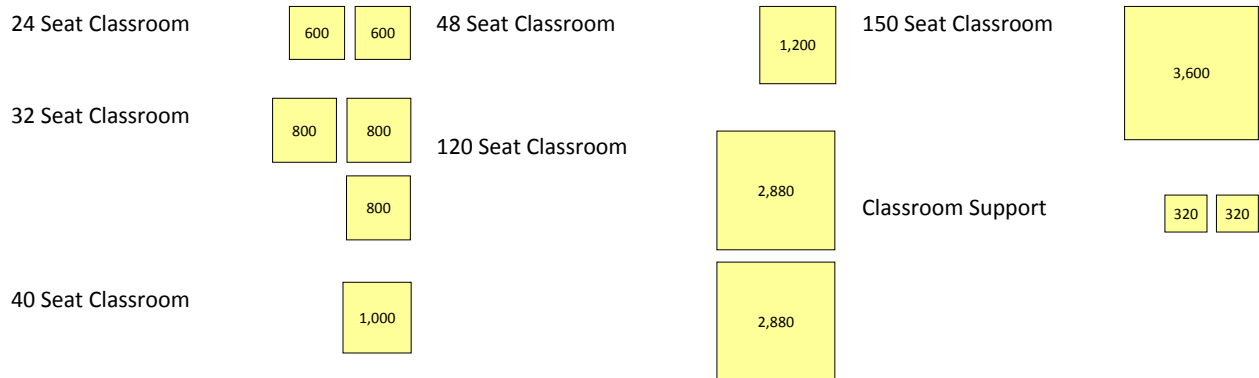

Unit 2: Miscellaneous Instructional/Support Spaces

Total Area: 18,881 ASF

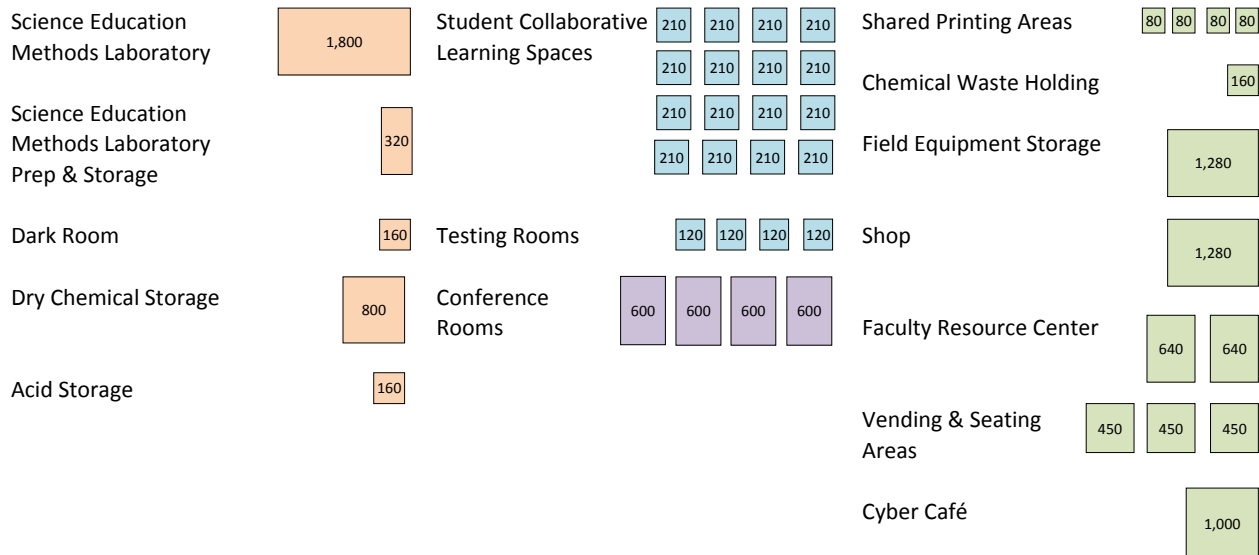

Legend

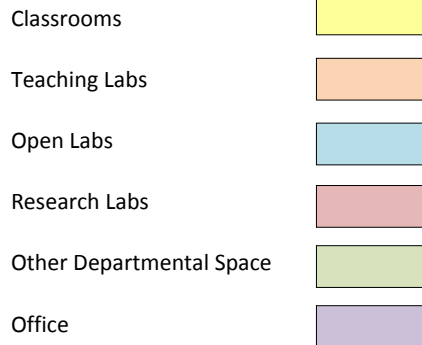

Division 2: Building Program

Unit 3: Biology

Total Area: 50,188 ASF

Department Chair's Office	120	Animal/Organizimal Laboratory	1,280	Environmental Chamber Room	400
Ranked Faculty Office	120 120 120 120 120 120 120 120 120 120 120 120 120 120 120 120 120 120 120 120	Botany Laboratory	1,280	Animal Rooms	960 960 960
		Cell Laboratory	1,280		960 960 960
	120 120	Genetics Laboratory	1,280		960 960
Future Ranked Faculty	120 120 120 120 120 120 120	Anatomy/Physiology Prep & Cadaver Storage	1,280	Procedure Rooms	480 480
Lecturer – Full Time	120 120 120 120			Cage Wash	320
	120	Introductory/Aquatics Prep/Storage	320 320	Storage	160 160
Lecturer –Part Time	120			Dirty Room	160
Support Staff/ Reception Area/Files	458	Animal/Organizimal/ Botany Prep/Storage	640	Lab Manger	120
Secure Office Storage	120	Cell Genetics Prep/ Autoclave	960	Herbarium	960
Workroom	120 120	Core Microscope Suite	960	Greenhouse	960
Teaching Assistants	120 120 120 120 120 120 120 120	PCR Suite	320	Headhouse	160
Graduate Assistants	120 120 120 120 120 120 120 120 120 120 120 120 120 120 120 120	Cold Room	320	Aquatics Space	160
	120	Biology Special Projects Laboratory	480	Isolation Space	320 320
Lab Support Staff	120 120 120	Faculty/Student Research (large paired lab)	1,440 1,440	Display Specimen	640
Introductory Biology Laboratory	1,280 1,280 1,280		1,440 1,440	Specimen Non-Display	320 320
			1,440 1,440	Office Area	60
Anatomy/ Physiology Laboratory	1,280 1,280 1,280	Faculty/Student Research (paired lab)	640 640 640	Rock Collection	160
				Table and Chairs	750
Aquatics Laboratory	1,280	Environmental Sample Processing Room	1,280	General Lab/ Departmental Storage	120 120 120

Division 2: Building Program

Unit 4: Chemistry

Total Area: 36,936 ASF

Department Chair's Office	120	Instrumental Chemistry Laboratory	1,280	Chemical Analysis Computer Lab	840
Ranked Faculty Office	120 120 120 120 120 120 120 120 120 120 120 120 120 120 120 120	Physical Chemistry Laboratory	1,280	Computerized Instrument. Lab	480
Future Ranked Faculty	120	General Chemistry Prep/Balance	640	Faculty/Student Research – Biochemistry	400 400
Lecturer – Full Time	120 120 120 120 120 120 120 120	General/Survey of Organic Prep/Balance	640	Faculty/Student Research – Synthesis	400 400
Lecturer –Part Time	60 60	General Chemistry II Prep/Balance	640	Faculty/Student Research – Analytical	400 400
Support Staff/ Reception Area/Files	446	Biochemistry Prep/Equipment	640	Faculty/Student Chemistry Education	400
Workroom	120	Organic Chemistry Majors Prep/Equipment	640	Faculty/Student Research – Physical/ Instrumental	400 400
Secure Office Storage	120	Analytical Chemistry Prep/Balance	640	Faculty/Student Research (computational)	200
Lab Support Staff	120 120	Instrumental /Physical Chemistry Prep/Balance	640	General Lab/ Departmental Storage	120
Student Workers	210	NMR	480		
General Chemistry I Laboratory	1,280 1,280	Stock Dispensing	960		
General Chemistry II Laboratory	1,280 1,280	Flammable Storage	320		
Biochemistry Laboratory	1,280 1,280				
Survey of Organic Chemistry Laboratory	1,280				
Organic Chemistry Majors Laboratory	1,280 1,280				
Analytical Chemistry Laboratory	1,280 1,280				

Division 2: Building Program

Unit 5: Geography & Earth Science

Total Area: 11,688 ASF

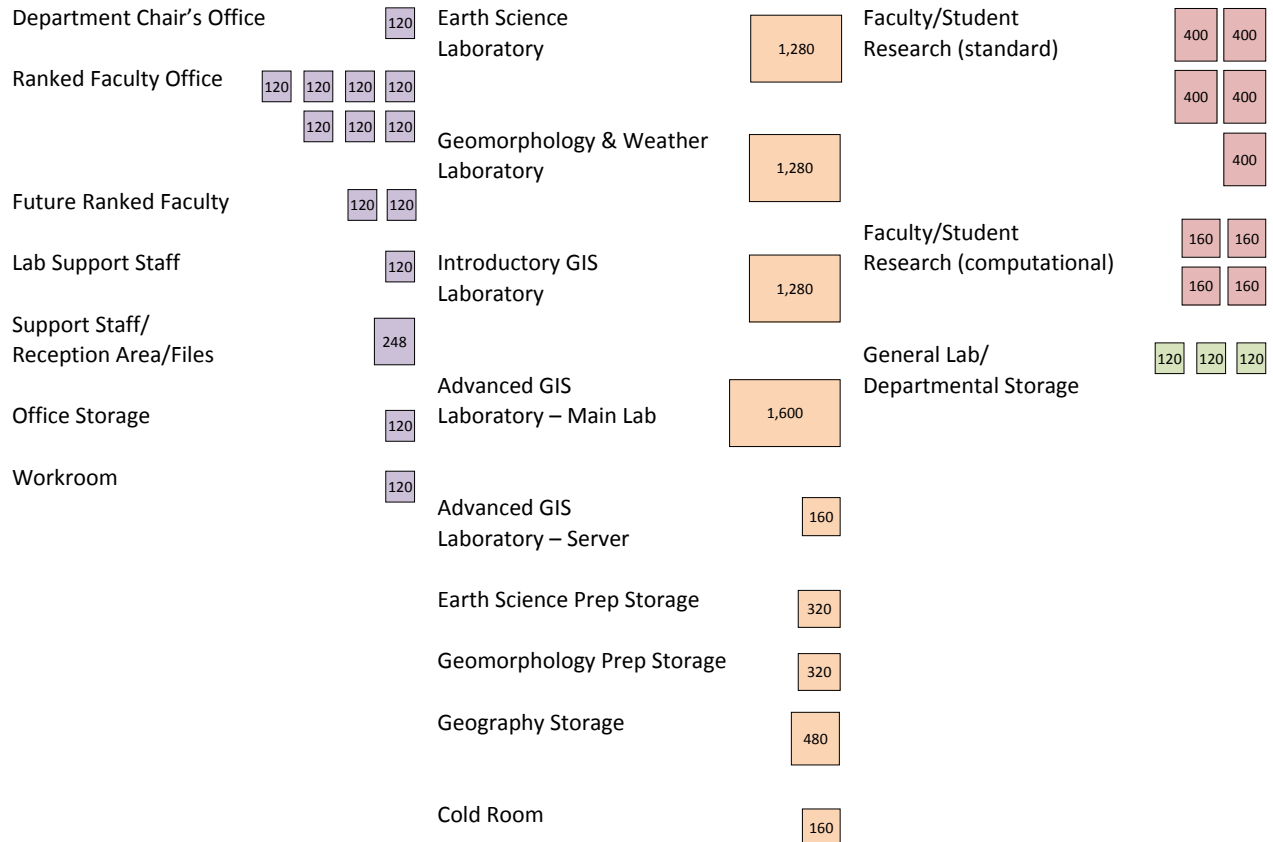

Unit 6: Mathematics

Total Area: 10,123 ASF

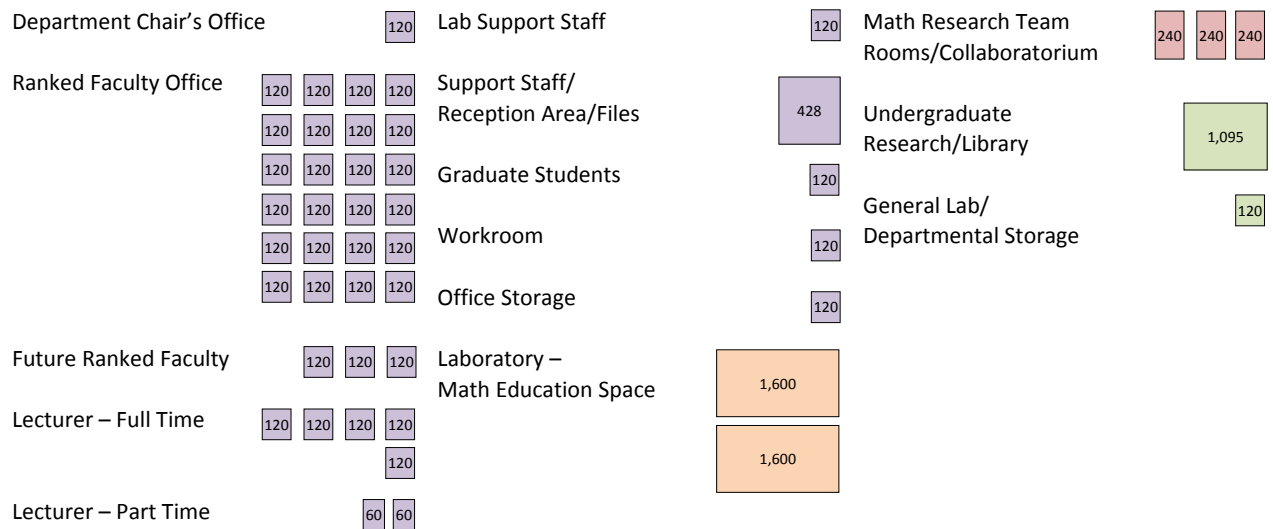

Division 2: Building Program

Unit 7: Microbiology

Total Area: 19,763 ASF

Department Chair's Office	120	Fundamental Microbiology Laboratory	1,280	Faculty/Student Research - Virology	960
Ranked Faculty Office	120 120 120 120	Pathogenic Bacteriology/ Medical Mycology Lab	1,280	Faculty/Student Research – Pathogenic	960
	120 120				
Future Ranked Faculty	120	Bacterial Physiology/ Genetics/Microbial Ecology	1,280	Faculty/Student Research – Genetics	960
Lecturer – Full Time	120 120 120 120				
Support Staff/ Reception Area/Files	283	Gen Ed/Food Microbiology/ Nutrition Laboratory	1,280	Faculty/Student Research – Immunology	640
Graduate Assistants/ Students	120 120 120 120	Immunology/Virology Laboratory	1,280	Faculty/Student Research – Bacterial Physiology	640
	120 120 120 120				
		120	Gen Microbiology Prep/ Autoclave	1,600	Faculty/Student Research – Microbial Ecology
Office Storage	120	Tissue Culture	320	Faculty/Student Research – Microbiology	480
Lab Support Staff	120 120 120	Centrifuge Room	480	Faculty/Student Research – Food Microbiology	480
		Fermentation Lab	800		
		Cold Room	160	General Lab/ Departmental Storage	360
		Equipment/Instrumentation Room and Storage	480		

Division 2: Building Program

Unit 8: Physics

Total Area: 20,622 ASF

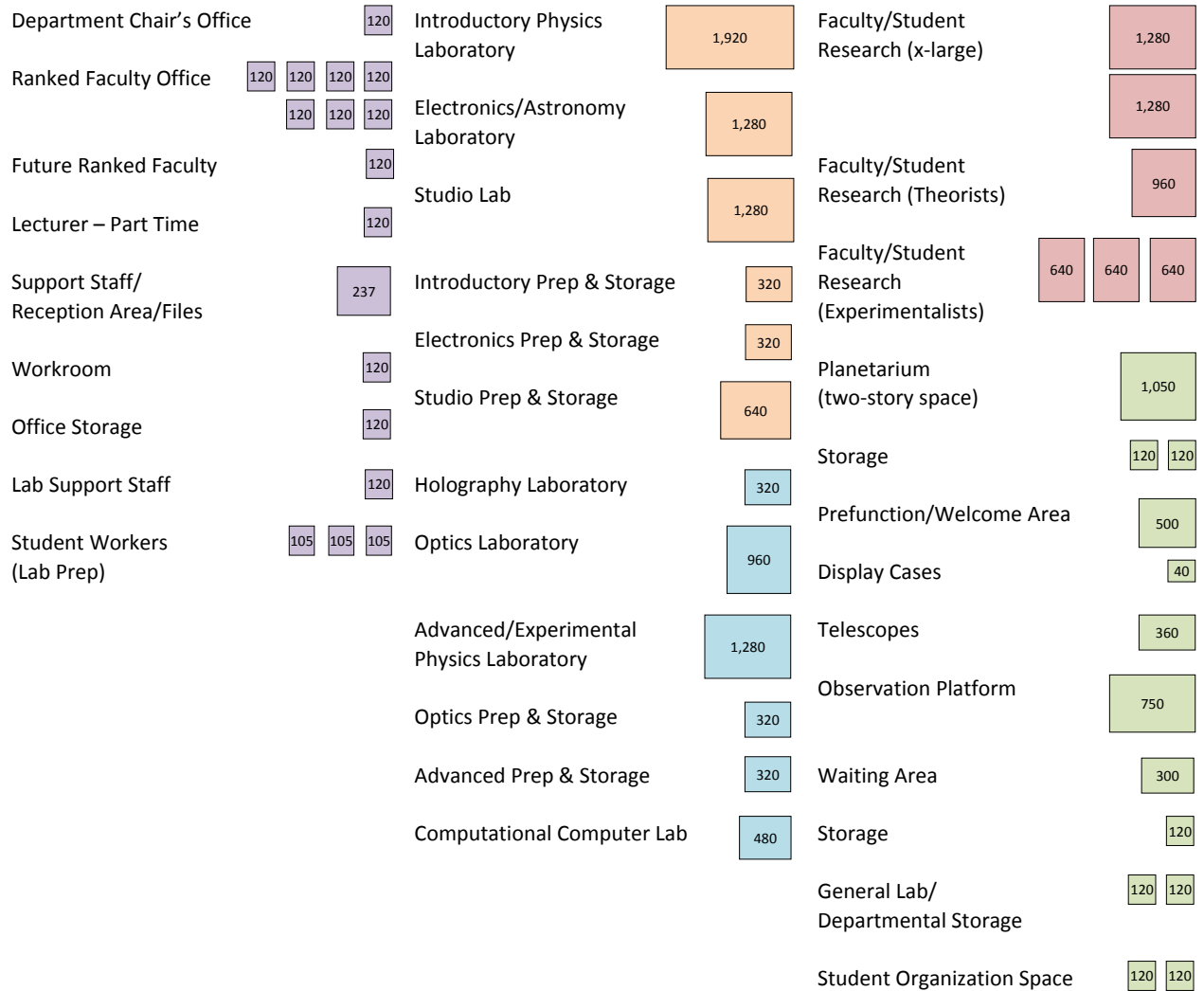

Division 2: Building Program

Unit 9: Radiation Center

Total Area: 5,400 ASF

Director/Safety Officer	120	Shared Isotope Prep	400	Nuclide Storage	160
Sealed Source Laboratory	1,280	Faculty/Student Research (Chemistry)	400	Neutron Howitzer	53
Open Source Laboratory	1,280	Faculty/Student Research (Physics)	1,280		
Laboratory Support – Stock Room	160	Special Instruments	267		

Unit 10: River Studies Center

Total Area: 3,520 ASF

Faculty/Student Research Wet Lab	1,440	Microscope – 11	160
Class 100 Clean Research Lab	320	Fish Culture – 42D	160
Faculty Student Research	1,440		

Unit 11: College of Science and Health – Dean’s Office

Total Area: 2,024 ASF

Dean’s Office	185	Support Staff/ Reception Area/Files	469	Storage	120
Associate Dean’s Office	145	Workroom	120	Grad Assistant/Advisor	120
Assistant to Dean’s Office	135	Conference Room	360	Administrative Specialist	120
Dean’s Assistant	135				
Assistant to Dean	135				

Unit 12: Building Support

Total Area: 7,720 NASF

Arrival Space Primary	1,500	Loading Dock	320	Custodial Closets	100 100 100 100
Arrival Space Secondary	900 900	Temporary Storage	640	IT Storage/Workroom	100 100 100 100
Equipment Storage	500	Building Recycling Collection Area	200	Uni-Sex Restrooms	70 70 70 70
Supply Storage	400	Recycling Area	25 25 25 25		70 70 70 70
Custodial Maintenance Room	200	IT & Electrical Closets	100 100 100 100 100 100 100 100		

2.8 Sample Room Layouts
TYPICAL 150 SEAT CLASSROOM

This layout is conceptual and is intended to show required furnishings, equipment, and general room proportions. The actual configuration may change.

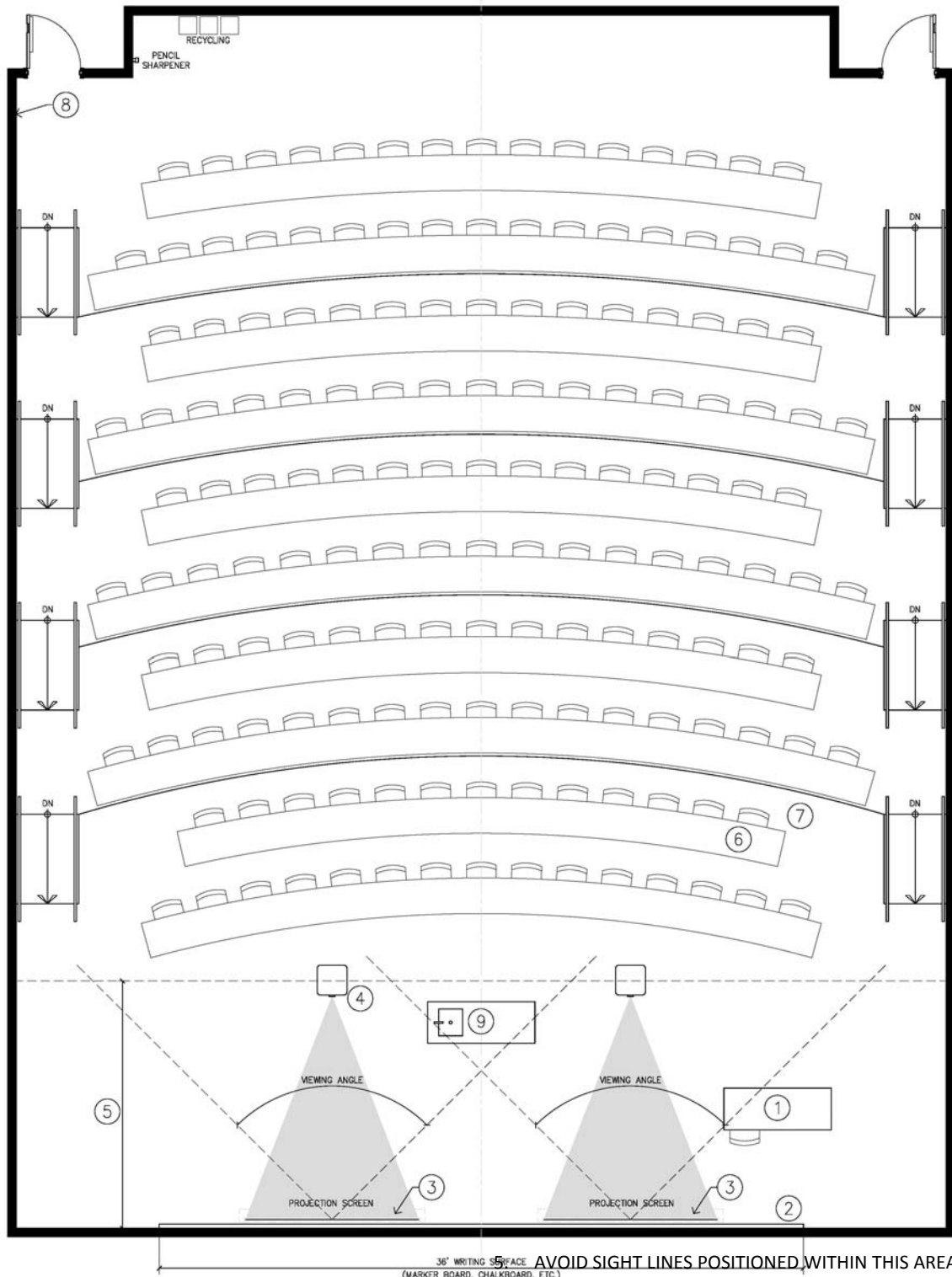

CLASSROOM FEATURES

- | | |
|-----------------------|------------------------------|
| 1. TEACHING PODIUM | 6. FIXED TABLE |
| 2. WRITING SURFACE | 7. MOVABLE CHAIR |
| 3. PROJECTION SCREEN | 8. ACOUSTICAL WALL TREATMENT |
| 4. OVERHEAD PROJECTOR | |

9. LABORATORY WORKSTATION

TYPICAL 120 SEAT CLASSROOM

This layout is conceptual and is intended to show required furnishings, equipment, and general room proportions. The actual configuration may change.

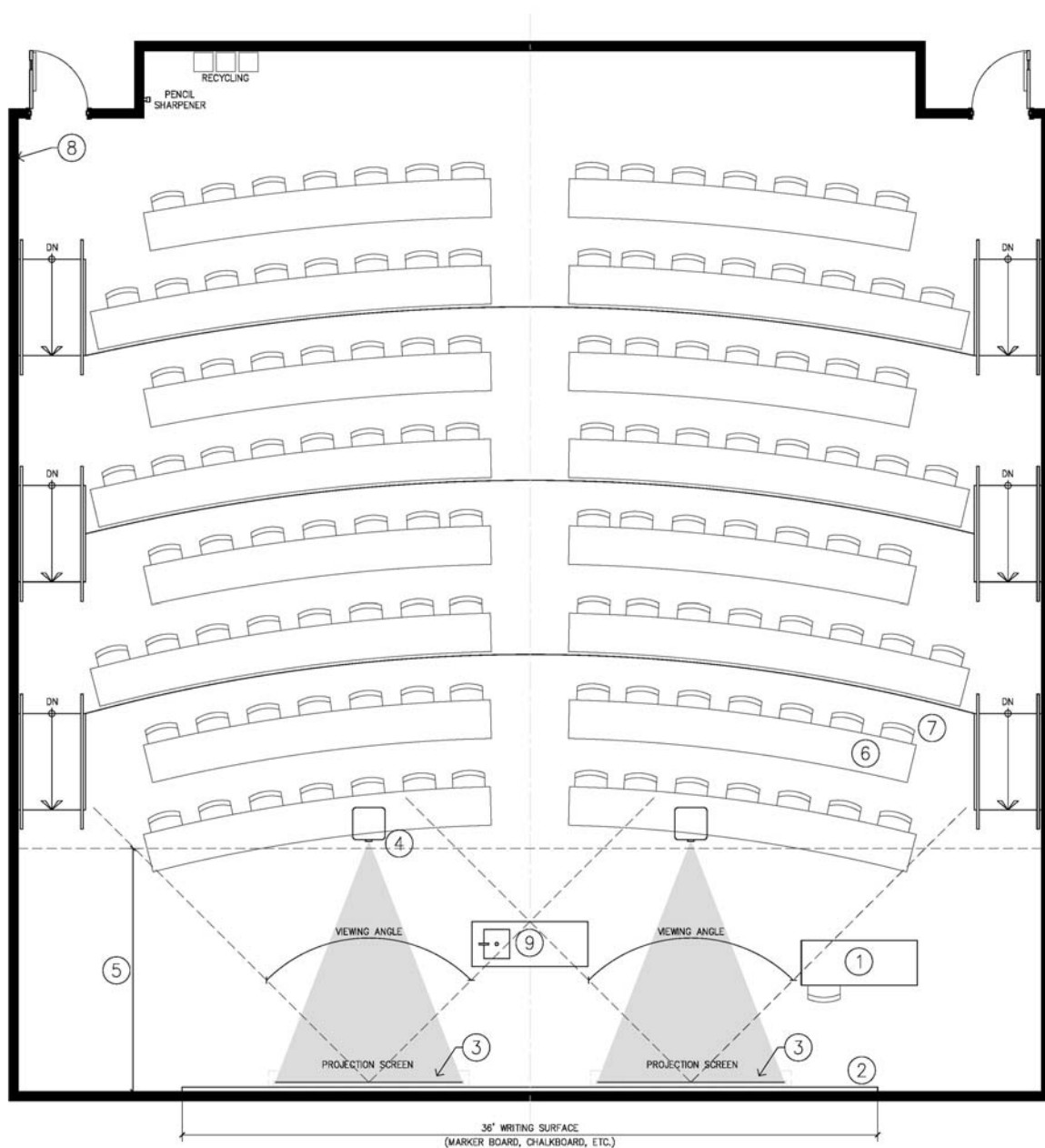

CLASSROOM FEATURES

1. TEACHING PODIUM
2. WRITING SURFACE
3. PROJECTION SCREEN
4. OVERHEAD PROJECTOR
5. AVOID SIGHT LINES POSITIONED WITHIN THIS AREA
6. FIXED TABLE
7. MOVABLE CHAIR
8. ACOUSTICAL WALL TREATMENT
9. LABORATORY WORKSTATION

Division 2: Building Program

TYPICAL 48 SEAT CLASSROOM

This layout is conceptual and is intended to show required furnishings, equipment, and general room proportions. The actual configuration may change.

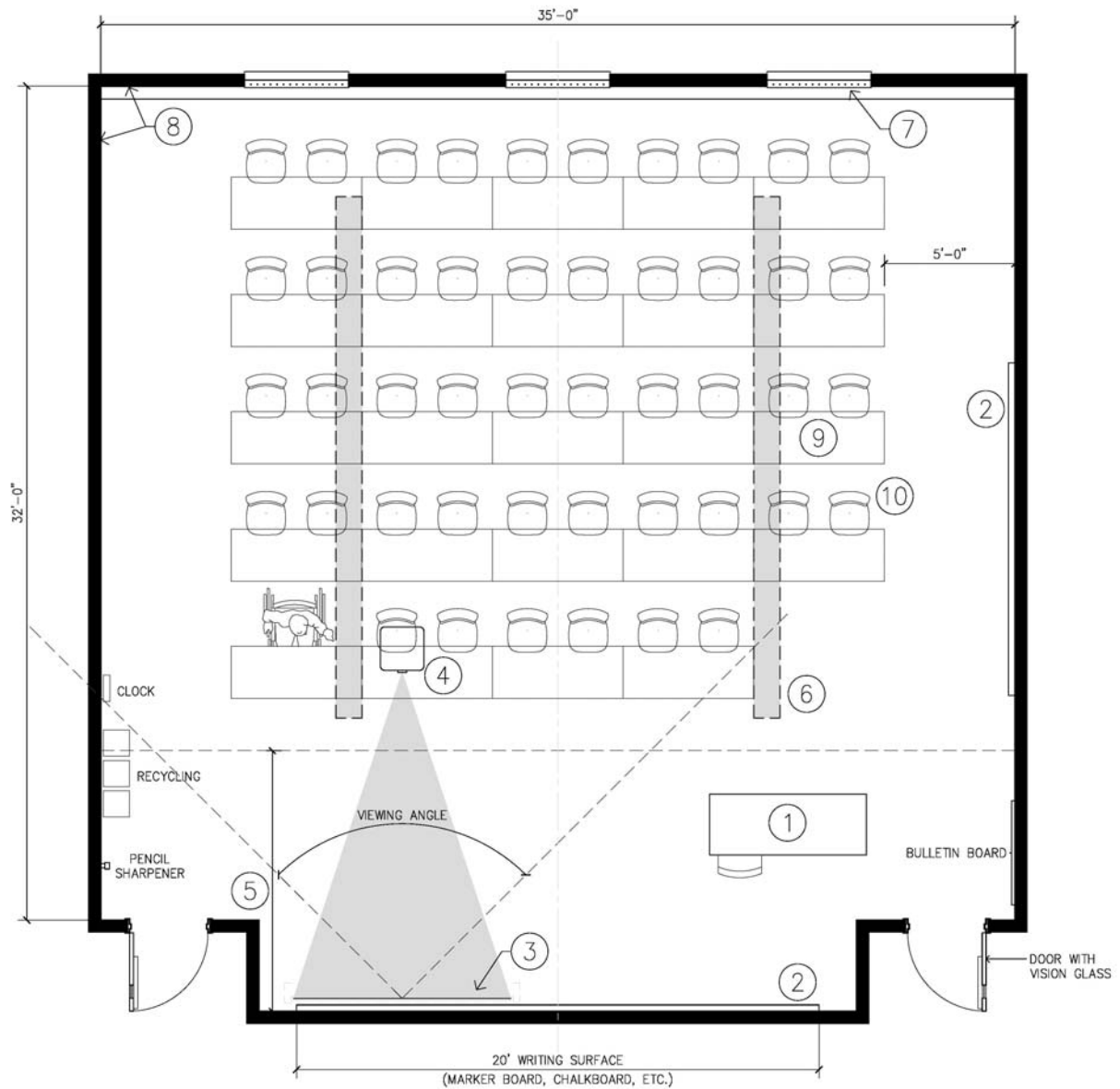

CLASSROOM FEATURES

1. TEACHING PODIUM
2. WRITING SURFACE
3. PROJECTION SCREEN
4. OVERHEAD PROJECTOR
5. AVOID SIGHT LINES POSITIONED WITHIN THIS AREA
6. DIRECT/IN-DIRECT LIGHT FIXTURE
7. ROLLER SHADE
8. WALL PROTECTION (CHAIR RAIL)
9. MOVABLE DESK
10. MOVABLE CHAIR
11. LEVEL FLOOR
12. ASPECT RATIO 1.1:1

Division 2: Building Program

TYPICAL 40 SEAT CLASSROOM

This layout is conceptual and is intended to show required furnishings, equipment, and general room proportions. The actual configuration may change.

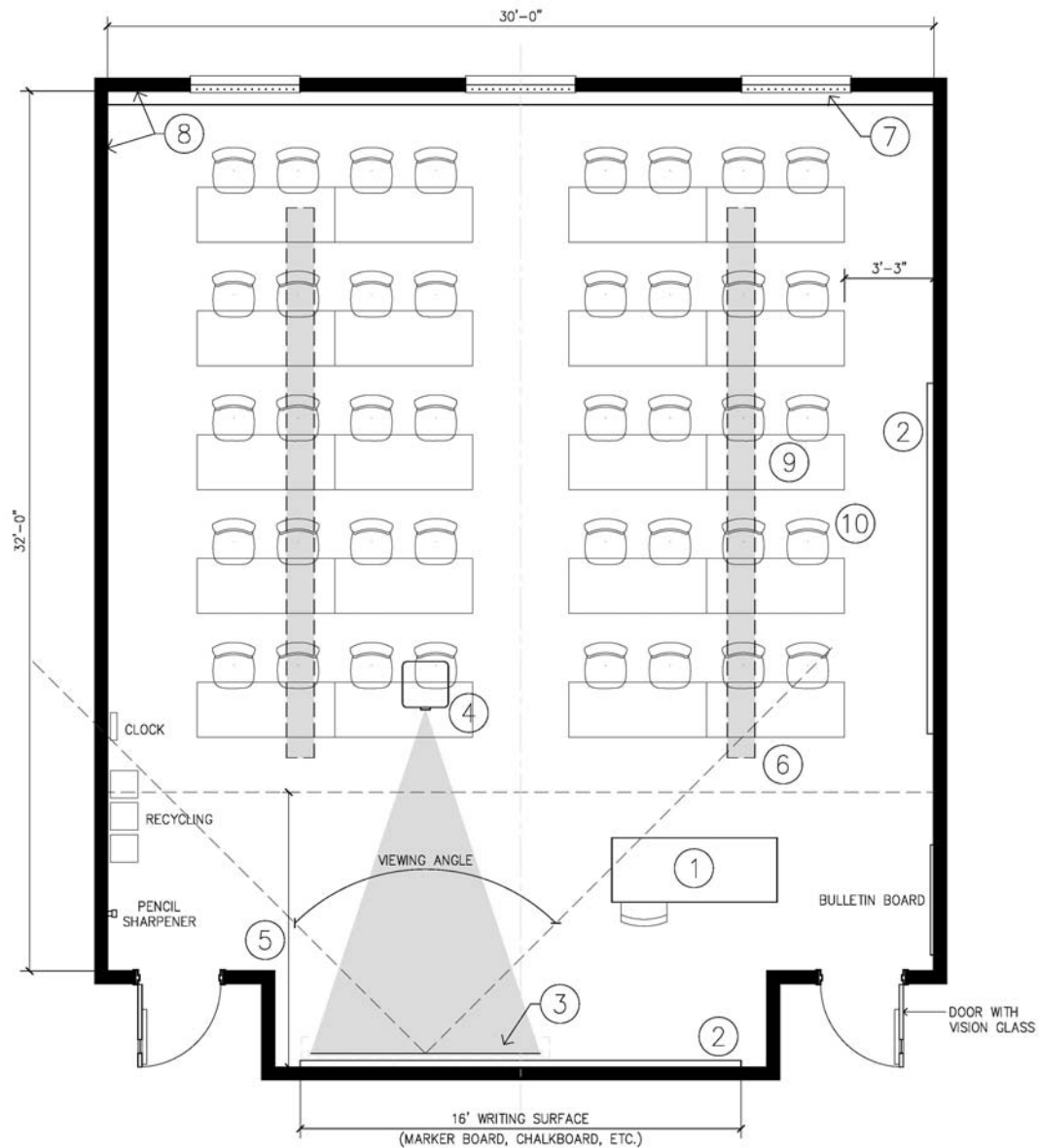

CLASSROOM FEATURES

1. TEACHING PODIUM
2. WRITING SURFACE
3. PROJECTION SCREEN
4. OVERHEAD PROJECTOR
5. AVOID SIGHT LINES POSITIONED WITHIN THIS AREA
6. DIRECT/IN-DIRECT LIGHT FIXTURE
7. ROLLER SHADE
8. WALL PROTECTION (CHAIR RAIL)
9. MOVABLE DESK
10. MOVABLE CHAIR
11. LEVEL FLOOR
12. ASPECT RATIO 1:1.1

TYPICAL 32 SEAT CLASSROOM

This layout is conceptual and is intended to show required furnishings, equipment, and general room proportions. The actual configuration may change.

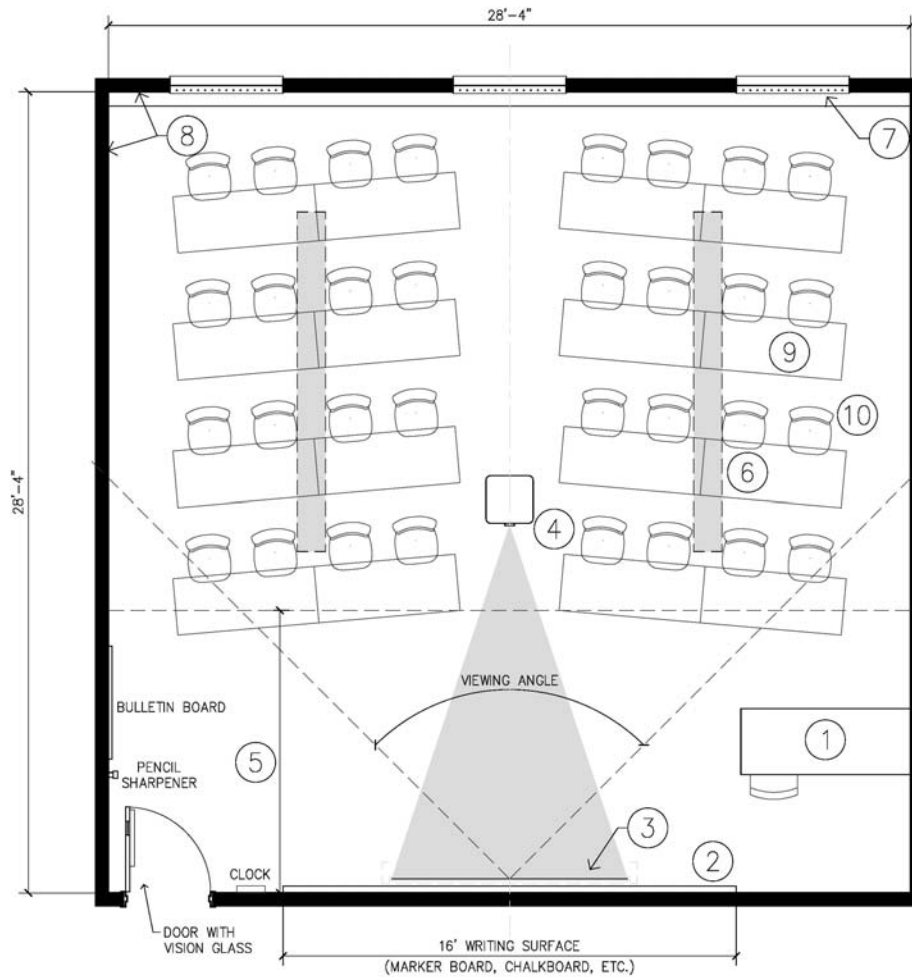

CLASSROOM FEATURES

1. TEACHING PODIUM
2. WRITING SURFACE
3. PROJECTION SCREEN
4. OVERHEAD PROJECTOR
5. AVOID SIGHT LINES POSITIONED WITHIN THIS AREA
6. DIRECT/IN-DIRECT LIGHT FIXTURE
7. ROLLER SHADE
8. WALL PROTECTION (CHAIR RAIL)
9. MOVABLE DESK
10. MOVABLE CHAIR
11. LEVEL FLOOR
12. ASPECT RATIO 1:1

TYPICAL 24 SEAT CLASSROOM

This layout is conceptual and is intended to show required furnishings, equipment, and general room proportions. The actual configuration may change.

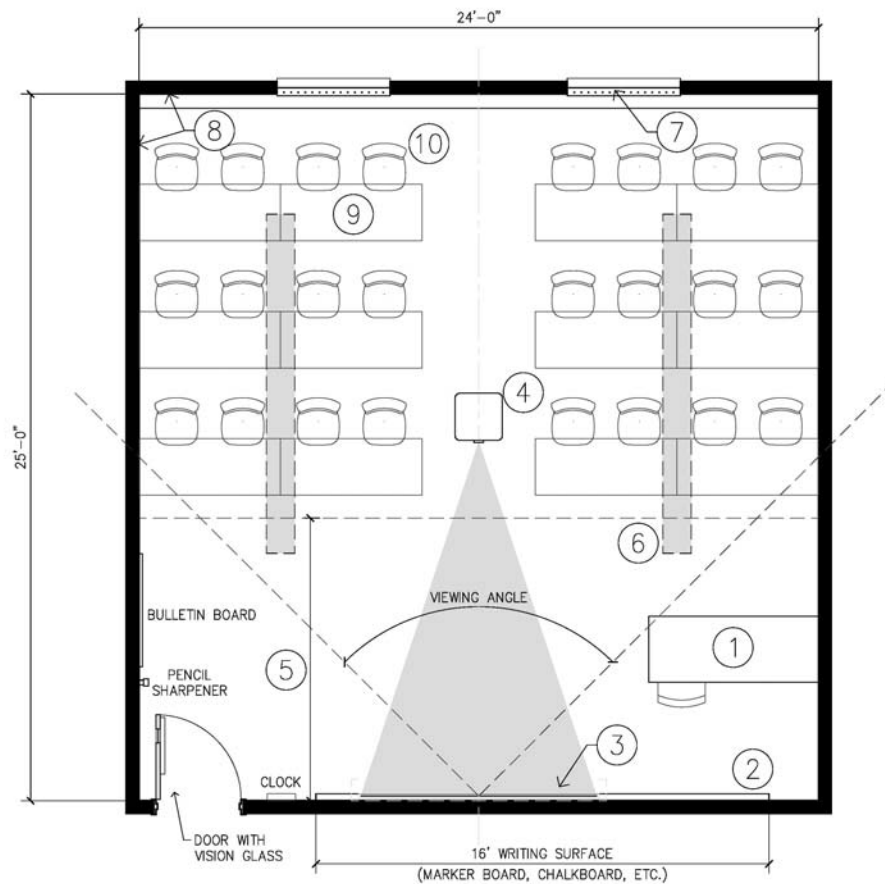

CLASSROOM FEATURES

1. TEACHING PODIUM
2. WRITING SURFACE
3. PROJECTION SCREEN
4. OVERHEAD PROJECTOR
5. AVOID SIGHT LINES POSITIONED WITHIN THIS AREA
6. DIRECT/IN-DIRECT LIGHT FIXTURE
7. ROLLER SHADE
8. WALL PROTECTION (CHAIR RAIL)
9. MOVABLE DESK
10. MOVABLE CHAIR
11. LEVEL FLOOR
12. ASPECT RATIO 1:1

Division 2: Building Program

TYPICAL TEACHING LABORATORY

This layout is conceptual and is intended to show required furnishings, equipment, and general room proportions. The actual configuration may change. Refer to Room Data Sheets for concept layouts for the various laboratory spaces.

Diagram represents (5) General Chemistry teaching labs.
See Appendix A: Room Data Sheets for the opportunity to reduce the number of CFH's from (6) to one by replacing the rest with down draft units at the student stations.

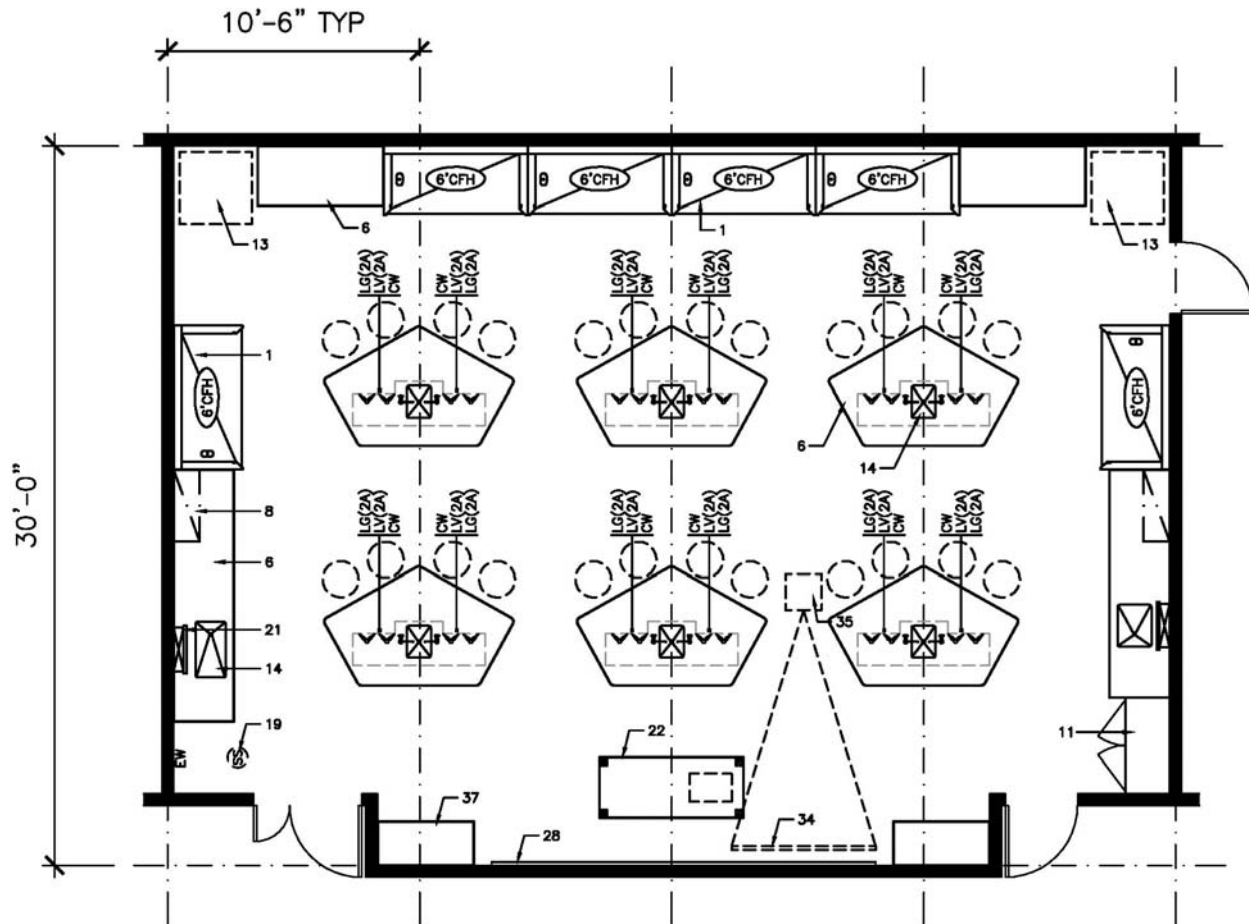

FURNISHINGS

- | | | |
|--------------------------------------|----------------------------------|---|
| 1. Chemical Fume Hood | 13. Equipment Space | 25. Autoclave |
| 2. Biological Safety Cabinet | 14. Laboratory Sink | 26. Moveable Laboratory Table |
| 3. Radioisotope Hood | 15. Cupsink | 27. Wire Shelving |
| 4. Vented Workstation | 16. Processing Sink | 28. White Markerboard |
| 5. Snorkel Exhaust | 17. Cylinder Rack | 29. Black Chalkboard |
| 6. Laboratory Bench, Standing Height | 18. Gas Cabinet | 30. Tackboard |
| 7. Laboratory Bench, Sitting Height | 19. Safety Shower/Eyewash | 31. Desk |
| 8. Wall Cabinet | 20. Overhead Service Carrier | 32. Balance Table |
| 9. Adjustable Shelves | 21. Pipe Drop Enclosure | 33. Writing Table |
| 10. Reagent Shelves | 22. Moveable Demonstration Bench | 34. A/V Screen |
| 11. Tall Storage Cabinet | 23. Glassware Washer | 35. Multi-media Projector (Ceiling Mounted) |
| 12. Vented Flammable Storage Cabinet | 24. Glassware Dryer | 36. File Cabinet |
| | | 37. Coat/Book Bag Storage Unit |

Division 2: Building Program

TYPICAL 480 SF CONFERENCE ROOM

This layout is conceptual and is intended to show required furnishings, equipment, and general room proportions. The actual configuration may change.

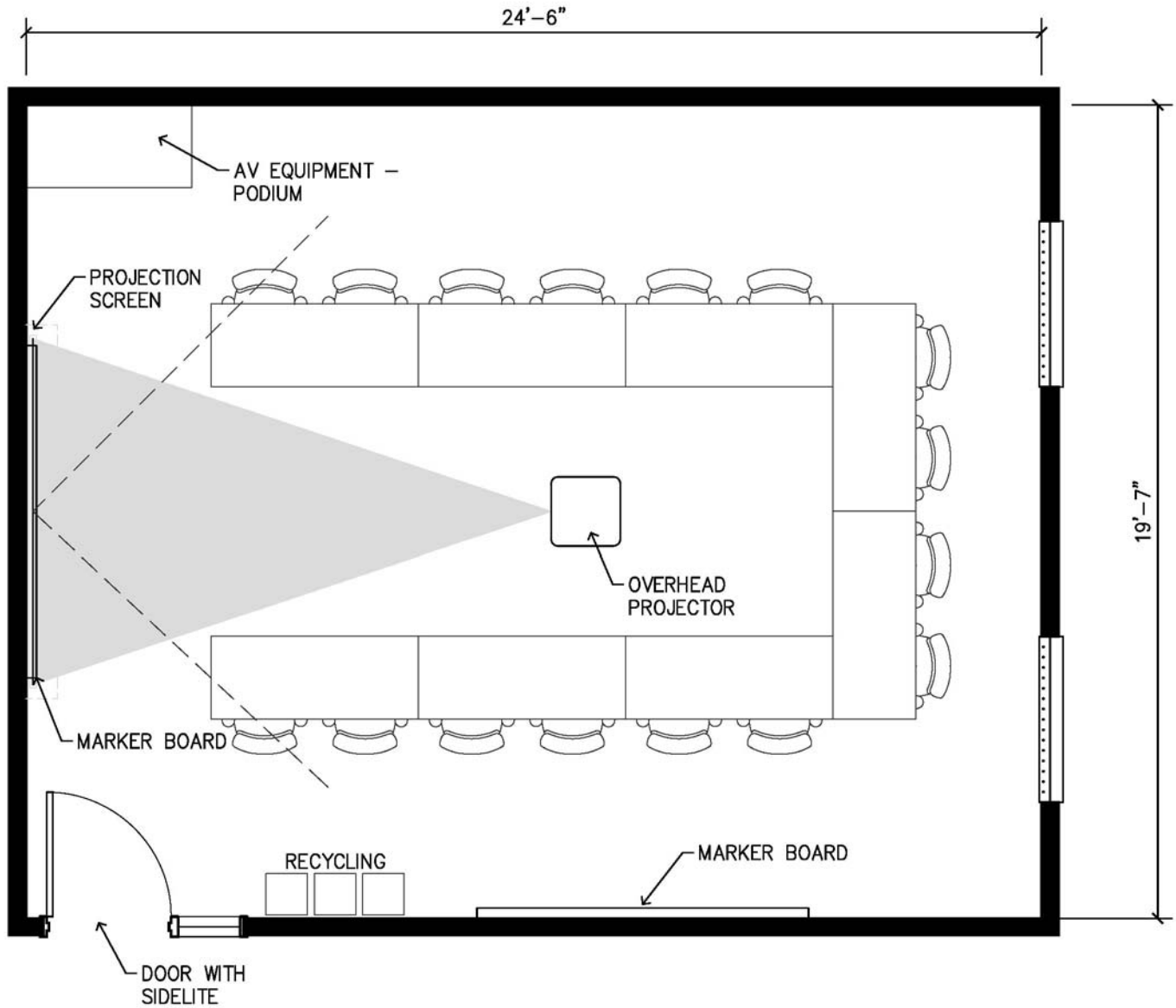

Division 2: Building Program

TYPICAL 240 SF CONFERENCE ROOM

This layout is conceptual and is intended to show required furnishings, equipment, and general room proportions. The actual configuration may change.

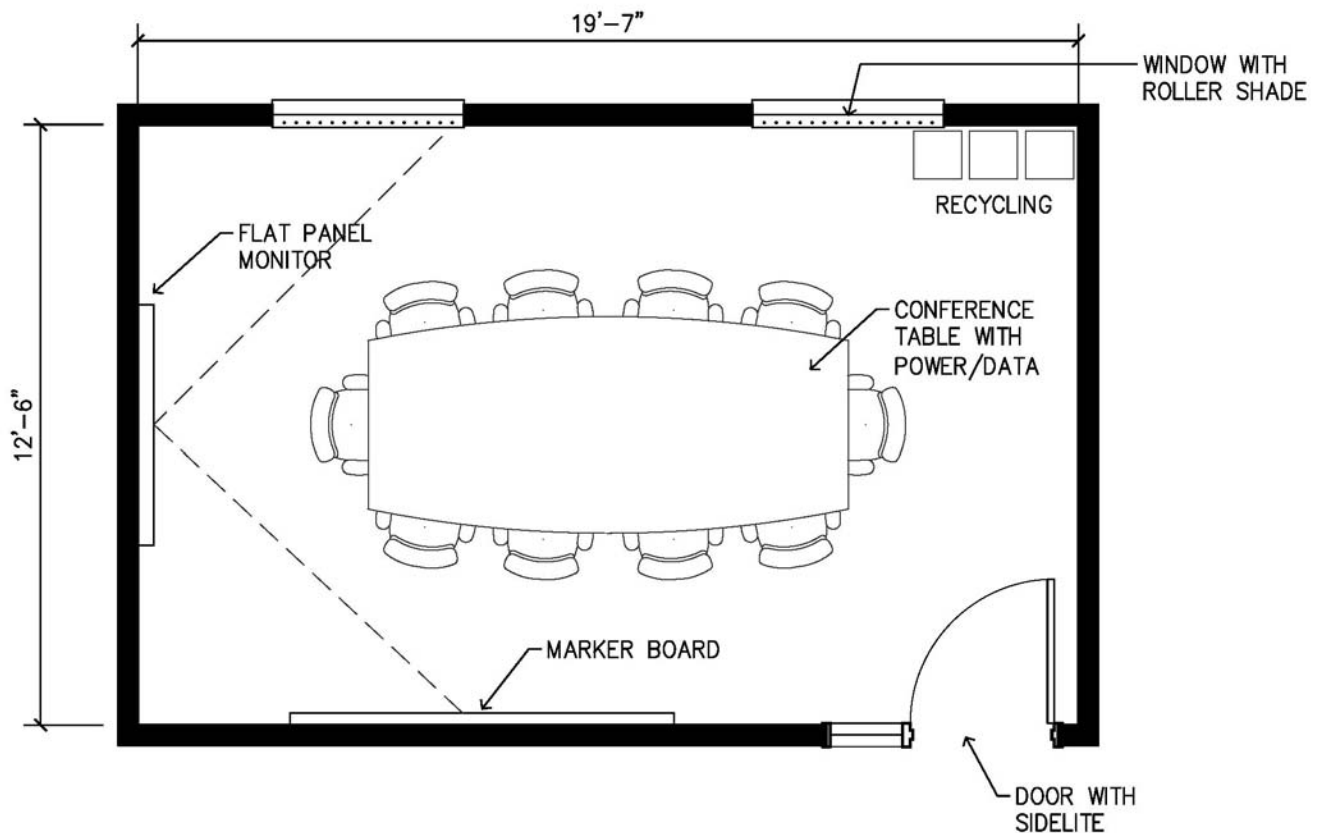

Division 2: Building Program

TYPICAL 185 SF OFFICE

This layout is conceptual and is intended to show required furnishings, equipment, and general room proportions. The actual configuration may change.

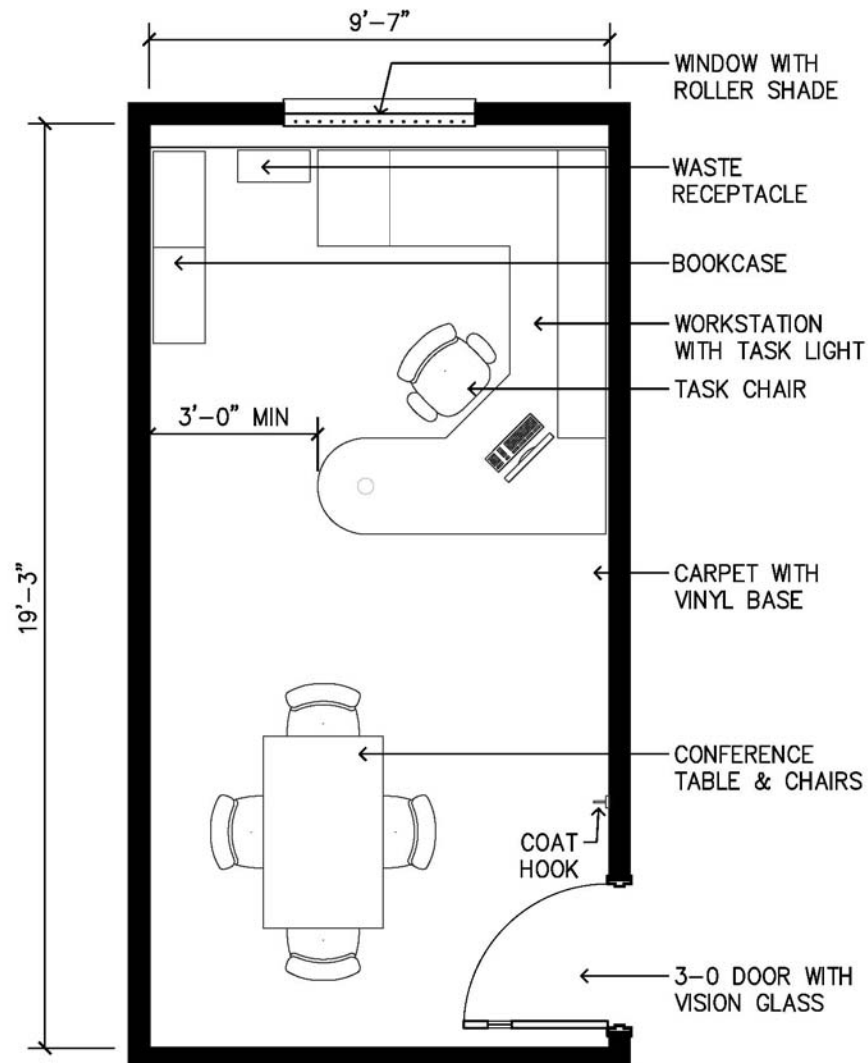

Division 2: Building Program

TYPICAL 160 SF OFFICE

This layout is conceptual and is intended to show required furnishings, equipment, and general room proportions. The actual configuration may change.

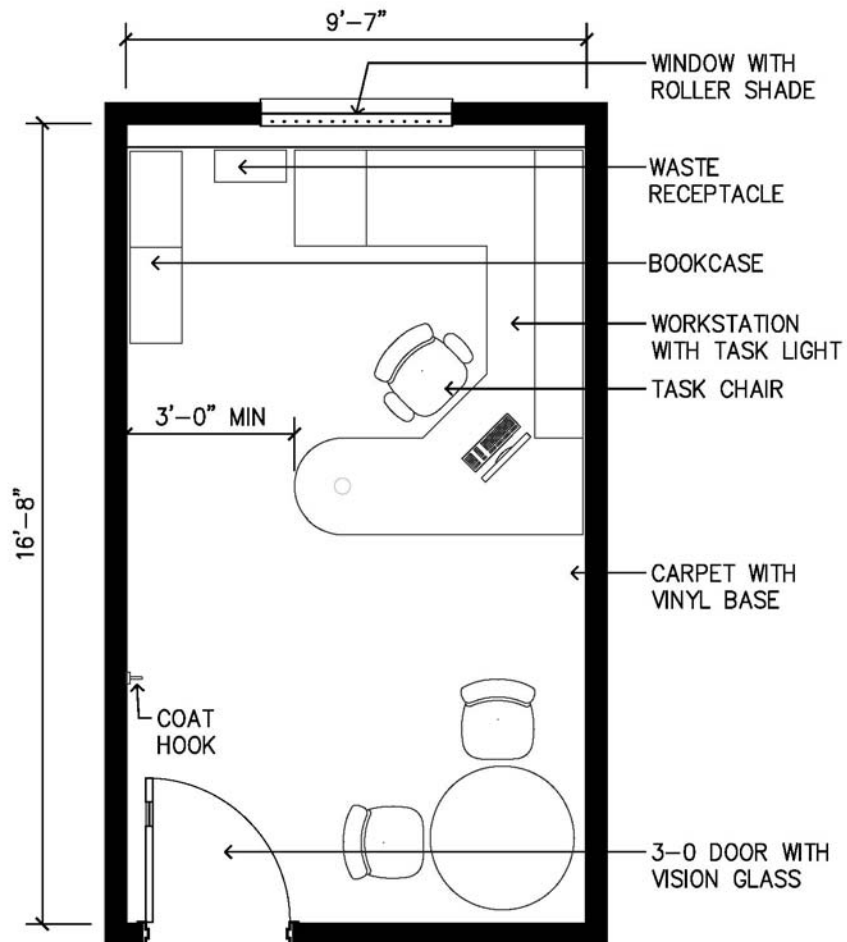

Division 2: Building Program

TYPICAL 120 SF OFFICE

This layout is conceptual and is intended to show required furnishings, equipment, and general room proportions. The actual configuration may change.

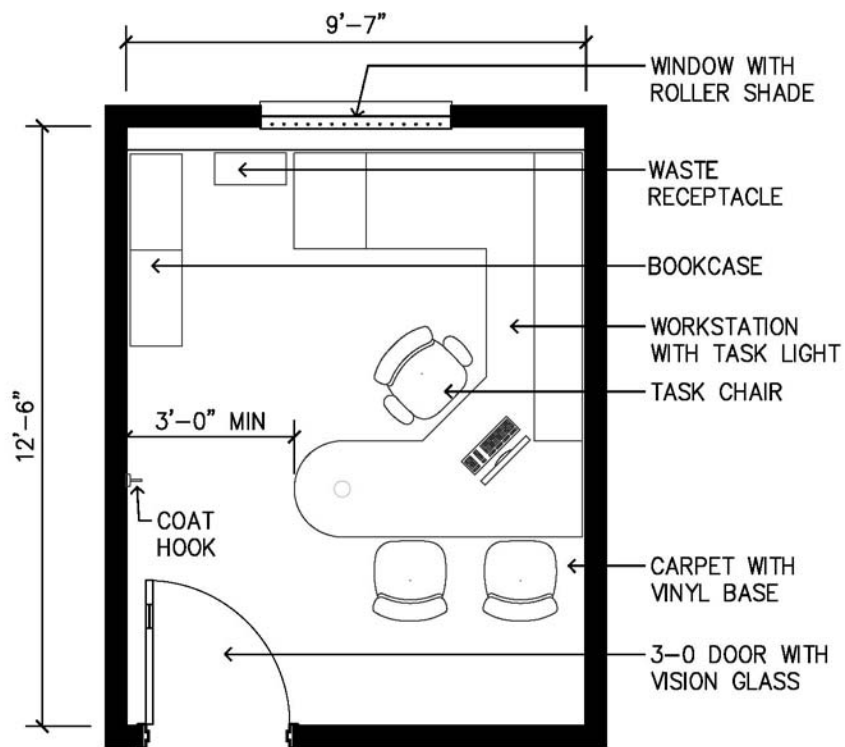

TYPICAL 120 SF STORAGE ROOM

This layout is conceptual and is intended to show required furnishings, equipment, and general room proportions. The actual configuration may change.

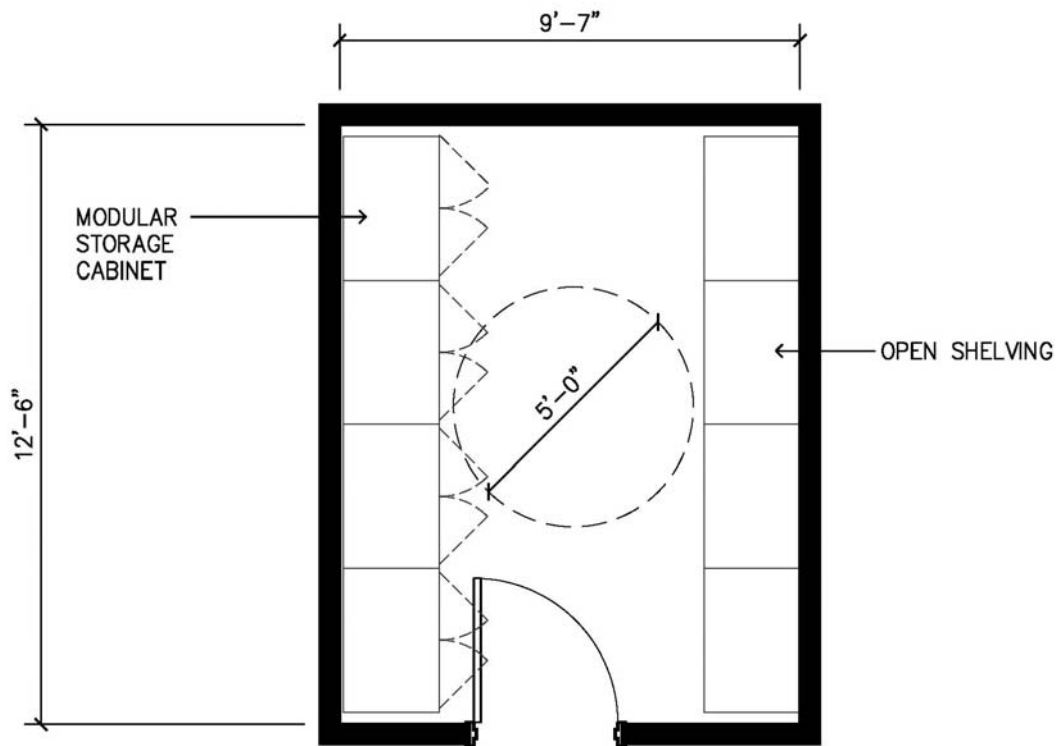

Division 2: Building Program

TYPICAL 120 SF WORK ROOM

This layout is conceptual and is intended to show required furnishings, equipment, and general room proportions. The actual configuration may change.

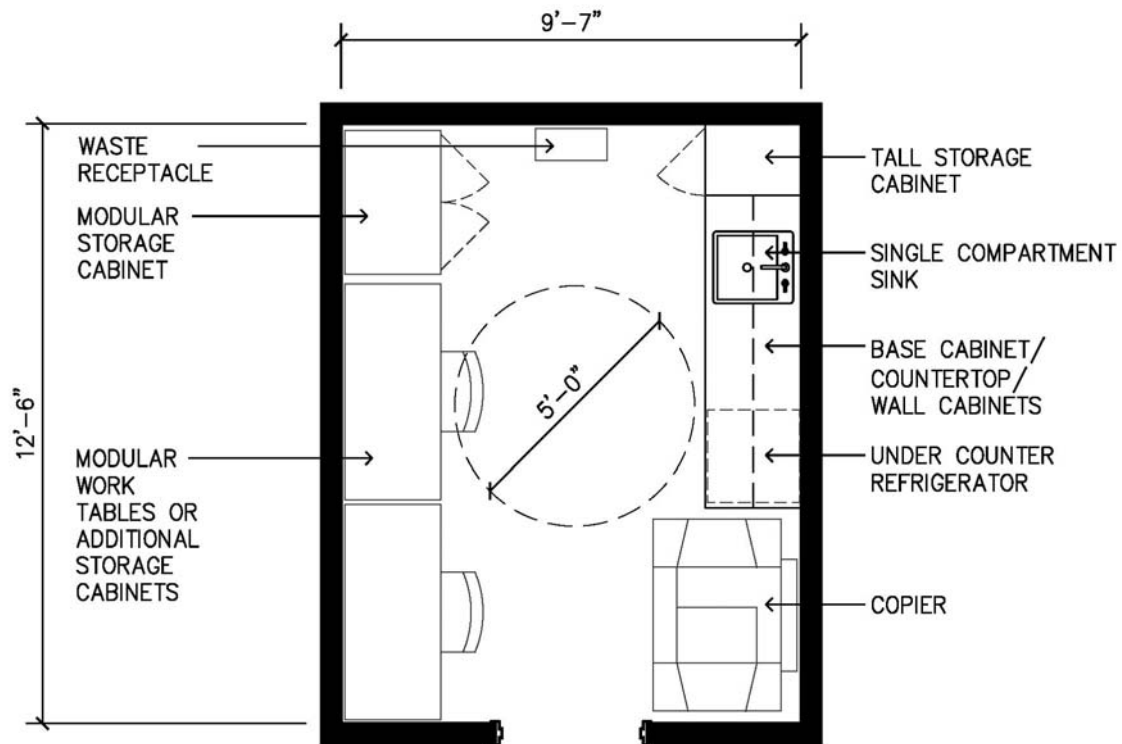

3.1 Site/Existing Conditions

3.1.1 Location, Proximity & Campus Neighborhood Context

The project will use the existing Cowley Hall site for the new expansion/renovation project. The site is essentially at the center of campus and is seated in a prominent location at the northeast corner of the main academic core of the University of Wisconsin-La Crosse campus. Cowley Hall shares the academic core with Wimberly Hall to the north, Murphy Library directly across the Mall to the west, the newly constructed Academic Building to the southeast, Wing Technology Center at the south end of the Mall and Wittich Hall immediately south of the project. The north-south axis of this academic core is intended to be developed into a future Central Campus Mall from Wimberly to Wing.

North of the site across Badger Street (a pedestrian & bicycle only zone), an existing parking lot will be the future site of a new Student Union Center (pre-design of which will be underway by mid 2011). Across East Avenue is the newly completed Veteran's Memorial Stadium and entry plaza. In addition to the prominent mall/academic core location, the site also fronts on East Avenue which is Campus' primary vehicular thoroughfare. Primary campus access is at the signalized intersection of East Ave. and La Crosse St. 2 blocks north of the site and the intersection of Pine St. and Campbell Road southeast of the site. As the site relates to student housing, it is centrally located though slightly closer to the northeast housing area.

The 2005 Campus Master Plan outlines many important factors that need to be considered during the development of the building and site. The Master Plan established three main principles: enhance the campus image and identity, create a Central Campus Mall within an enhanced academic core, and create a more walkable campus environment.

In that respect the proposed site development will play an integral role in fulfilling the master plan. The location, massing and final design will need to enhance the campus image and identity as well as having a lasting effect on the academic core. The building will also play an interactive role for visitors as they enter and explore campus. Visitors will approach campus via the signalized intersection at East and La Crosse, be directed west onto Farwell St. and enter a new parking structure (currently in design development). Now on foot, visitors will interact with a proposed Visitor's Center on the corner of Farwell and East and the new Student Union Center. As they explore the rest of campus, visitors will likely cross the Badger St. pedestrian corridor and head for the Central Campus Mall, passing by or through the new Cowley Science building.

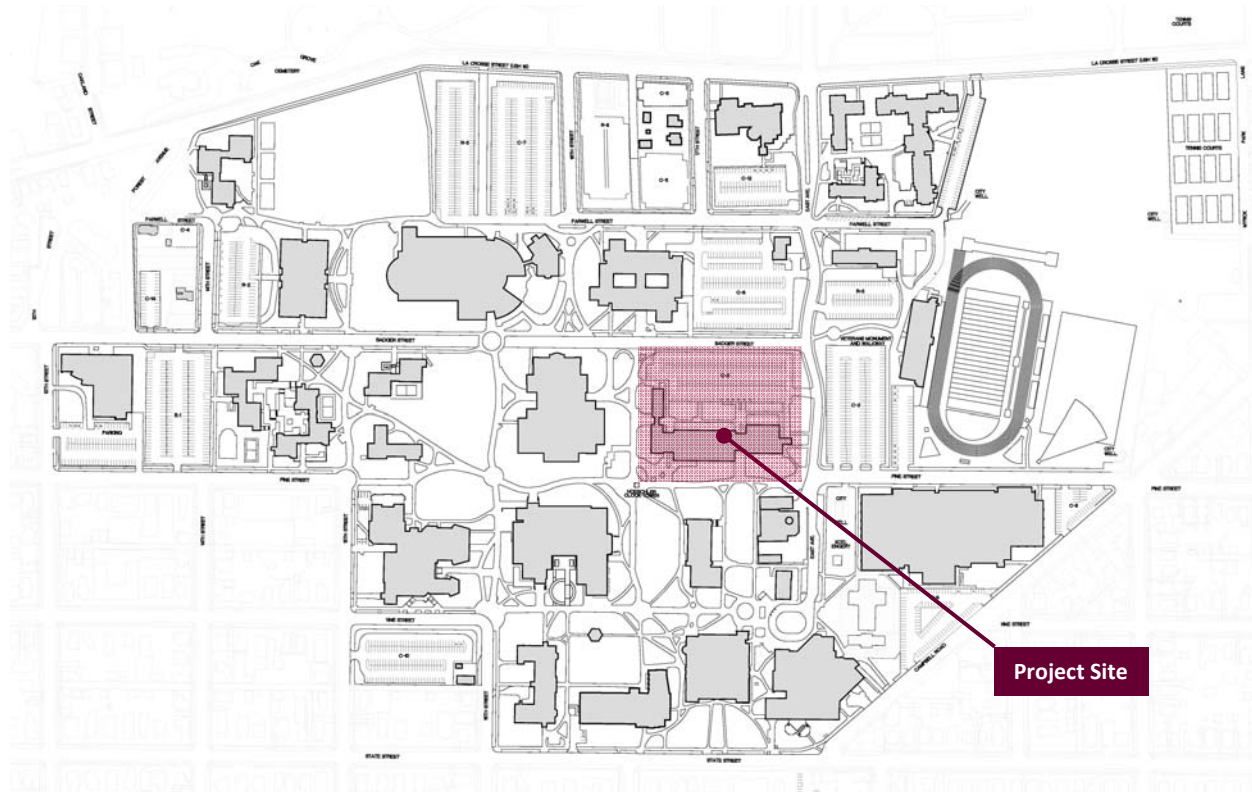

Site Location Map



Division 3: Physical Planning Issues

In addition to the guiding principles there are notable physical and geographical campus changes in the Master Plan. East Ave. may eventually extend south and connect to Campbell Road directly. At such time the road geometry may be straightened. Badger St. is currently an abandoned road profile complete with curb and gutter, terrace and sidewalks on both sides. The Master Plan identifies this as a future Enhanced Pedestrian Corridor, likely to consist of less pavement and more landscape which will give the corridor a pedestrian character and scale. A future Central Campus Mall is planned for the north-south axis east of the site from Wimberly to Wing. As mentioned, the site immediately north will soon be the new Student Union Center. This development will impact a large portion of campus circulation as it exists today. A new parking structure and police station are being planned for the parking lots located just north of Wimberly hall. This development will also affect circulation to and around campus.

The Master Plan intentions and prominent campus location give this site a very urban character suggesting that the new development provide for life and activity on all sides of the building. Given the site location on campus, proximity to the academic core and street frontages, no one side wants to be the back door. Future design development will need to be mindful of campus developments and these influences

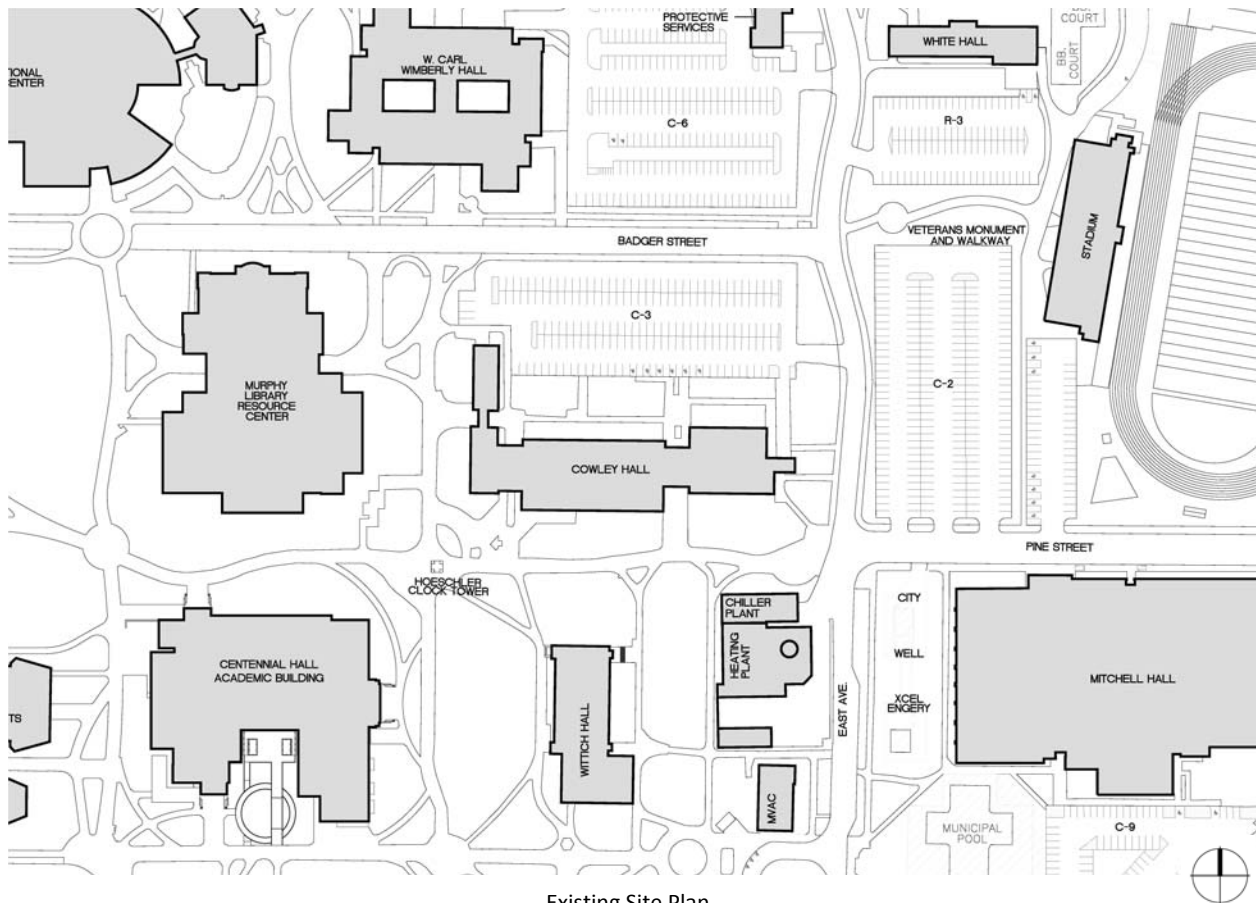

Existing Site Plan

3.1.2 Site Analysis

The existing site is based on the typical City of La Crosse street grid. As with most areas of Campus, the streets have either been abandoned or are closed. The whole of the academic core is based on the street grid layout and as such most of the site utilities occur primarily in the corresponding grid layout (storm, sanitary, water, gas). Additional Campus utilities predominantly follow the same grid but some utilities do vary in location i.e chilled water, primary and signal.

The site itself is relatively free of utilities other than a storm sewer network serving the existing parking lot. The south edge of the project has a primary and signal package encroaching into the project site. Final building placement, foundations and layout will need to assess the feasibility of maintaining these services as is or propose to relocate. Soil borings have not been conducted but recent

projects at the Stadium and Academic Building reveal extremely sandy subsoils below a thin layer of topsoil. This soil structure creates ideal opportunities for infiltration. Unfortunately a portion of the site resides in a City Well Head Protection Zone and as such places infiltration restrictions within that area alone. Areas of the site outside of this zone should be utilized for infiltration if possible.

The site is generally open and free of shade and is predominantly square to the cardinal directions. As such the site is subject to the winter winds from the northwest and summer winds from the southwest. Solar orientation is typical with the south face of the existing building in direct sun and the north portion subject to shadows. Proposed vegetation solutions and site snow removal considerations should be designed in that respect. Vegetation on site includes mature trees, foundation landscaping and miscellaneous landscape beds and sod but nothing of great significance. The site is proximal to the Campus iconic clock tower, undoubtedly a landmark and the extent of site work around the

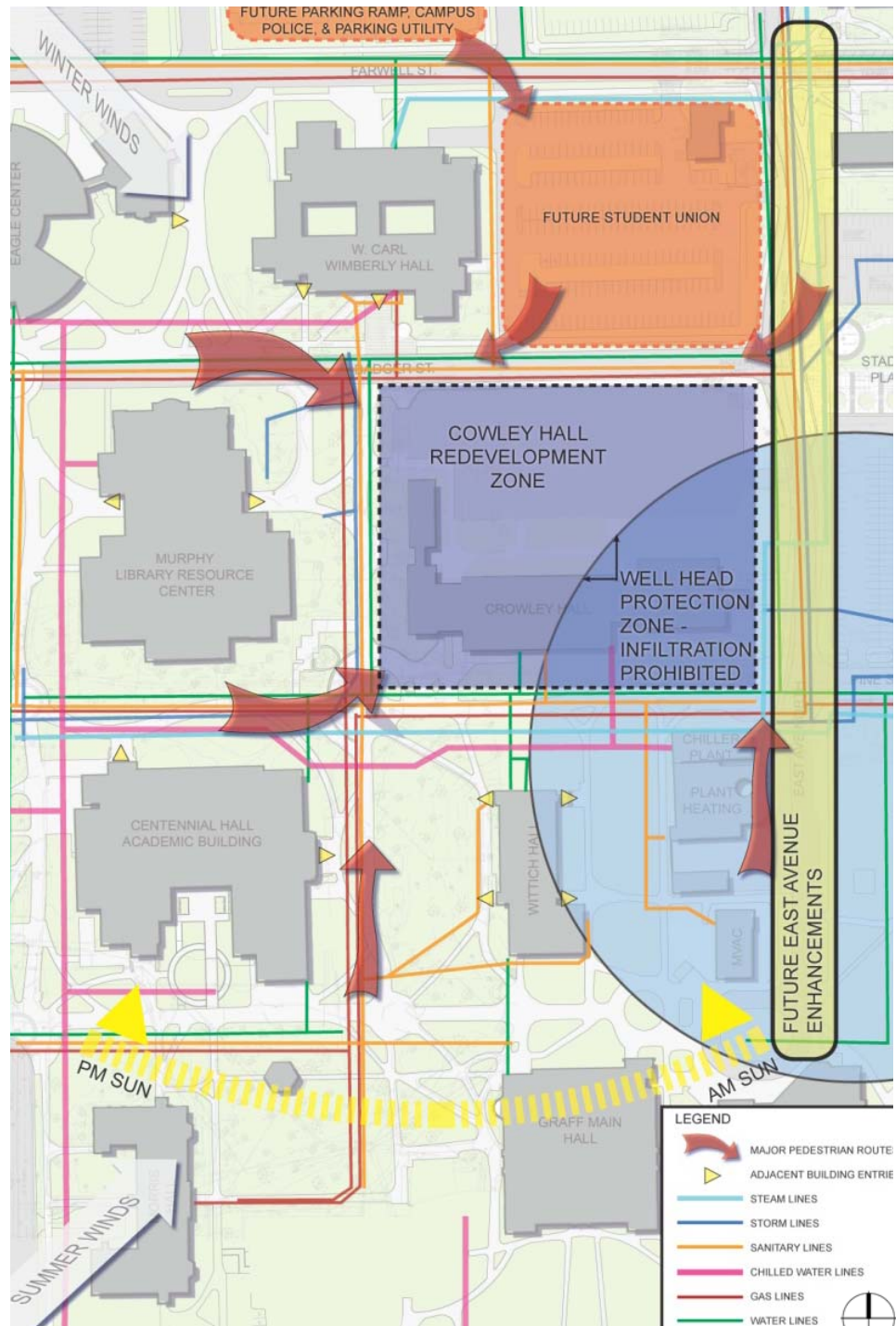

Site Analysis

Division 3: Physical Planning Issues

clock to be included in the final site restoration should be considered early in the design development. Current scope for the Cowley project includes site restoration as it relates to the building design options, but does not include wholesale changes in the Central Campus Mall or clock tower areas. Care should be taken to protect and maintain conditions as feasible in the final project scope.

Badger Street is currently treated as a pedestrian corridor despite the existing street profile. Service vehicles and security are the only motorized vehicles currently allowed. As this project progresses, opportunities to redesign a portion of Badger Street in conjunction with the new Student Union Center should be explored. Together these projects could develop the Campus Master Plan suggested improvements for at least a portion of this corridor.

East Avenue is main vehicular thoroughfare through campus and will remain as such as identified in the Campus Master Plan. East Ave also carries a significant amount of pedestrian traffic on its sidewalks though this will likely change with the Student Union Center project relocation. The Stadium however will continue to generate significant traffic and flow even if only limited to events.

3.1.3 Topography

The overall site slopes gently from northeast to southwest at an average of 0.8%. The northeast corner being the high point with an elevation around 671.5. Grade along Badger Street slopes west resting at 670.0 where Badger St. meets the future central mall. Grade in the mall slopes approximately 1.0% to the south with an elevation of 666.44 at the clock tower in the center of the mall. The south edge of the site slopes moderately at 0.7% east to west. Approximate grade at the intersection of East Ave. and the east-west sidewalk is 670.3. Generally the site appears flat but clearly an elevation change exists across the site and is more prominent when attempting to level a large footprint. Grade may be a factor when attempting to site the building addition and/or renovation. Existing floor elevation of Cowley is 669.59 which is approximately 1' lower than the corner of Badger St. and East Ave.

The existing parking on the north half of the site drains internally and is served by a small stormwater network. Most of the parking area discharges to the storm main in the Central Mall while the southeast corner of the parking lot is served by a catchbasin and connects to the storm main in East Ave.

Topography around the west and south areas of the building allows for surface drainage away from the building and site and is collected via catchbasins in the center of the mall and the corridor south of the building.

3.2 Civil Utilities and Plan
Site Utility Plan

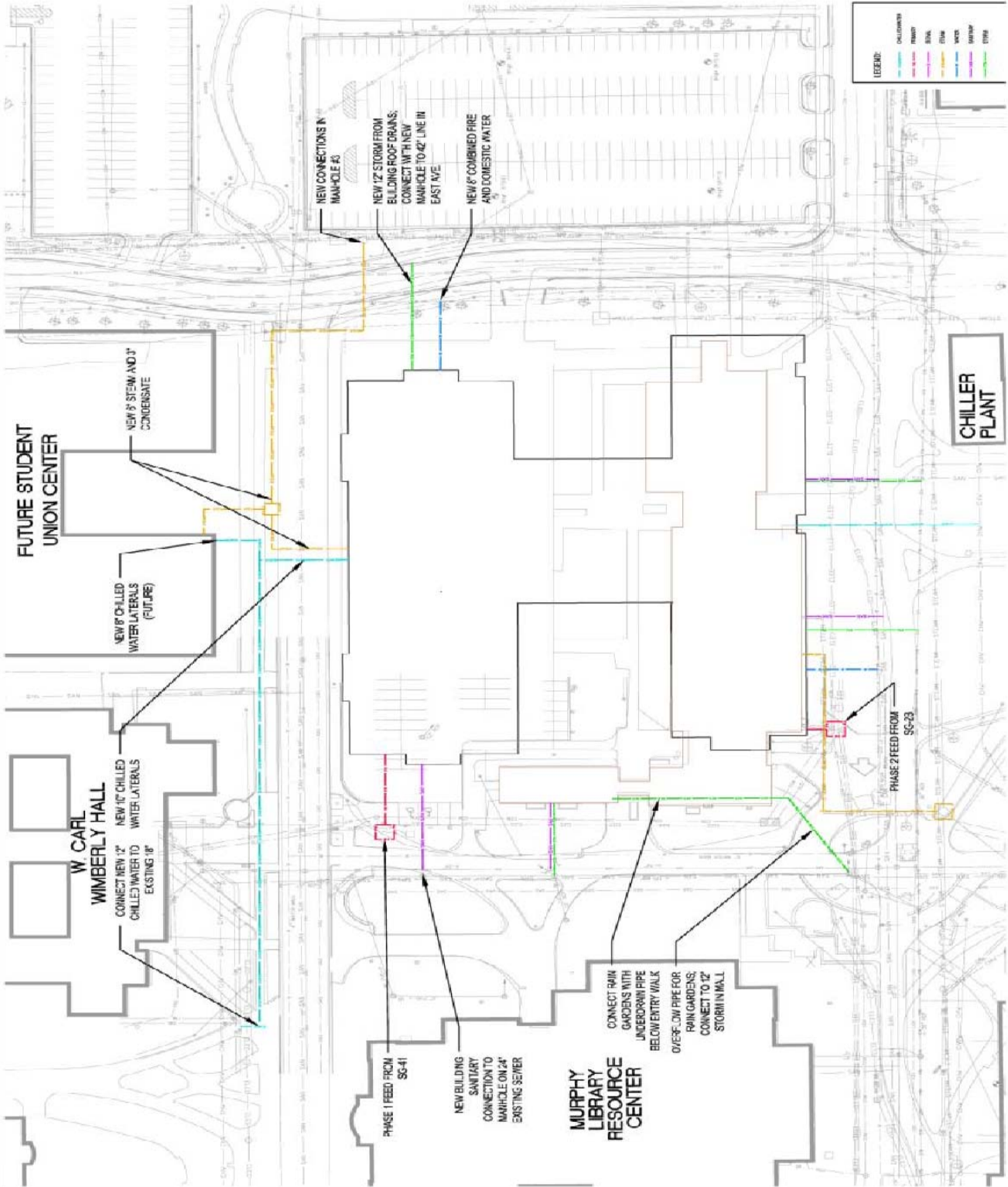

Division 3: Physical Planning Issues

3.2.1 Water

The current Cowley Hall domestic water connection is located on the south side of the building, which connects to a 20-inch water main that runs east-west through the old Pine Street abandoned right of way. A 6-inch main loops around the Cowley site on the north, east and west. A fire flow test performed in June 2007 by the City on the 6-inch line near the corner of East Ave and Badger Street resulted in a flowrate of 1,706 gpm at a residual pressure of 55 psi (static pressure of 78 psi).

All water for domestic, fire protection, and laboratory needs will be drawn from the public supply. The Pre-Design Team has assumed that no gray water will be collected or used for the building plumbing or irrigation. A private well is located on site that currently supplies clean well water for certain water-research laboratories. It is anticipated that this well will be abandoned because of its location and relocated in a manner that doesn't impact the ability to infiltrate storm water on site and is also outside of the City of La Crosse's Well Protection Zone. Final determination of the need for well water will be determined during the design phase.

The Cowley Renovation and Addition project will be done in phases, so the existing building will need to remain occupied and functioning while the new addition is being constructed. It is anticipated that the new addition will require an 8-inch domestic and fire protection water service in addition to the existing service (size unknown).

A water connection to the East Ave water main for the new building is recommended. However, the most capacity is likely to be available via the current water connection to the 20-inch main on the south.

If it is determined that the existing 6-inch water loop is not adequate to provide the fire flow capacities for the new addition, it may be feasible to use the existing building connection to feed the existing and new building additions.

3.2.2 Storm

Drainage & Connections

The existing building has a storm connection for roof drainage near the center of the building on the south side. This storm pipe connects to a 36-inch storm sewer in the old Pine Street that flows west towards the Clock Tower.

There are several existing storm sewer systems near the project site. A 12-inch storm pipe runs towards the south along the mall west of the project site and connects to the 36-inch at the Clock Tower. On East Avenue to the east of Cowley Hall, a 42-inch pipe flows north towards the river. A cross connection between the 42-inch and the 36-inch pipes exists at the intersection of East Ave and Pine Street. The cross connection functions by allowing stormwater to flow in either direction (north or west) to alleviate flooding caused by one system backing up during large storm events.

The parking lot north of Cowley Hall, which is the site of the future addition, is currently drained via several catch basins to the west pedestrian mall. An additional catch basin in the southeast corner of the Cowley project site drains to East Ave. Therefore the project site is located at the divide of two major sewersheds in the vicinity of campus.

In discussions with the City of La Crosse Public Works Department, the 42-inch pipe in East Ave has the greatest capacity of any system near the site.

The area around the Clock Tower currently experiences flooding, according to the UW La Crosse Stormwater Management Plan (2008). This is apparently due to a combination of a lack of positive drainage and lack of capacity of the downstream system. With this in mind, the Design Team recommends that the roof drainage from the future addition be directed to the 42-inch pipe in East Ave.

Infiltration, Peak Flow Reduction & Sediment Removal

Infiltration potential on the eastern half of the site is prohibited due to the fact that it is within 400 feet of a municipal water well. In addition, a new well for water-research laboratories could have an impact on potential infiltration area and process on the remaining site. Soils in the area are generally sandy and have very high infiltration capacity.

Opportunities for treatment of total suspended solids (TSS) and peak flow reduction are somewhat limited on this site during the "interim" condition (after Phase 1 is built but before Phase 2 is done when the west wing will be demolished). The most effective best management practices (BMPs) would be a combination of grass swales and biofiltration areas for infiltration (rain gardens). The site lends itself better to having rain gardens on the west side of the building, where there is more space. However, this is in the footprint of the existing west wing, so BMPs would need to be constructed as part of Phase 2 construction. Unfortunately, the capacity of the existing storm sewer is greater on the east side of the site, where infiltration is prohibited and there is a lack of space for rain gardens. Therefore, the site drainage will need to be split between east and west

Division 3: Physical Planning Issues

to direct some water towards the rain gardens but not so much as to overwhelm the system.

The City reviews all projects on campus for stormwater management goals. The campus (like the City) has a goal of reducing TSS in their runoff by 40 percent over a condition where there are no BMPs. In addition, the City is planning to implement a Stormwater Utility beginning in 2011 that will assess fees against property owners (including the university) based on the amount of impervious area on a property. The Utility will allow credit reductions for property owners who employ BMPs to reduce stormwater peak flows as well as capture TSS. The more TSS captured and the better peak flow reduction, the less the property owner will pay in fees.

The Division of State Facilities (DSF) has Sustainability Guidelines similar to the LEED rating system. Two credits (SS C6.1 and SS C6.2) relate to stormwater management. For this project, these guidelines are summarized as follows:

SS C6.1 – Stormwater Quantity: reduce the rate and volume of stormwater discharge by 25 percent for the 1.5-year, 24 hr storm event.

SS C6.2 – Stormwater Quality: capture 80 percent of TSS and 40 percent of total phosphorus (TP) from the runoff over no controls over an annualized period.

LEED has similar criteria for each credit. Both of these credits are achievable with the use of rain gardens and bioswales on this site, but meeting these will require a portion of the building roof water to be directed to the rain gardens to be infiltrated.

In summary, with the use of two rain gardens on the west side of the site and grass swales elsewhere around the building, it is possible to achieve the stormwater management goals as defined by DSF, DNR, the City of La Crosse, and LEED.

3.2.3 Sanitary

The existing sanitary service line from Cowley Hall is on the south side, which discharges to a 10-inch sanitary sewer that runs west in the abandoned Pine Street right of way towards the Clock Tower. A 24-inch sewer, located just west of Cowley Hall, runs south along the pedestrian mall. This is the best location for receiving sanitary flows from the new Cowley Hall addition, and a manhole already exists near the northwest wing of Cowley Hall. The new addition will require a 6-inch sanitary sewer connection in addition to the existing service connection on the south.

According to the City there should be sufficient capacity in the 24-inch sewer as the only facilities that are serviced by it are university properties to the north.

3.3 Transportation/Circulation

3.3.1 Bus & Vehicular Access

Two bus routes serve campus with one route passing directly by the site on East Ave. The bus system is moderately used though more so during the colder months. No bus shelter exists on East Ave. and the existing site does not generate high ridership. However, the new site development along with the future Student Union Center will increase pedestrian traffic flow to this region of campus and the site. Appropriate accommodations should be considered during the design development of the Cowley project and in conjunction with the new Student Union Center.

Vehicular traffic comes in two forms: service vehicles and general civilian traffic. Current service for Cowley is at the east end of the building with primary access via the existing parking lot. Future service will need to accommodate room for 4 dumpsters (2 trash, 1 recycle, 1 cardboard) with room to maneuver and parking for at least 3 service vehicles as well as 3-4 accessible stalls. In addition parking and loading (small straight body trucks) for lab equipment should be accommodated, likely 2-3 stalls or a general designated loading area. The current parking lot will be removed and no new onsite parking is planned. Campus is currently embarking on a new parking structure project as discussed in the project location section of this report. This parking structure will offset the loss of parking resulting from the Cowley and new Student Union Center projects. An adjacent visitor lot is located across East Ave. at the Stadium but most users of the new building are anticipated to be approaching by bicycle, moped or by foot.

3.3.2 Bicycle & Moped

The Campus Master Plan identifies the academic core of campus as a bike and moped free zone. Bicycles are allowed through the academic core but should be walked through and not ridden. Major bicycle routes are intended to be via Badger, Pine (east of the project site) and East Ave. To encourage and strengthen the academic core pedestrian nature provisions for bicycle and moped parking should be designed on building edges and

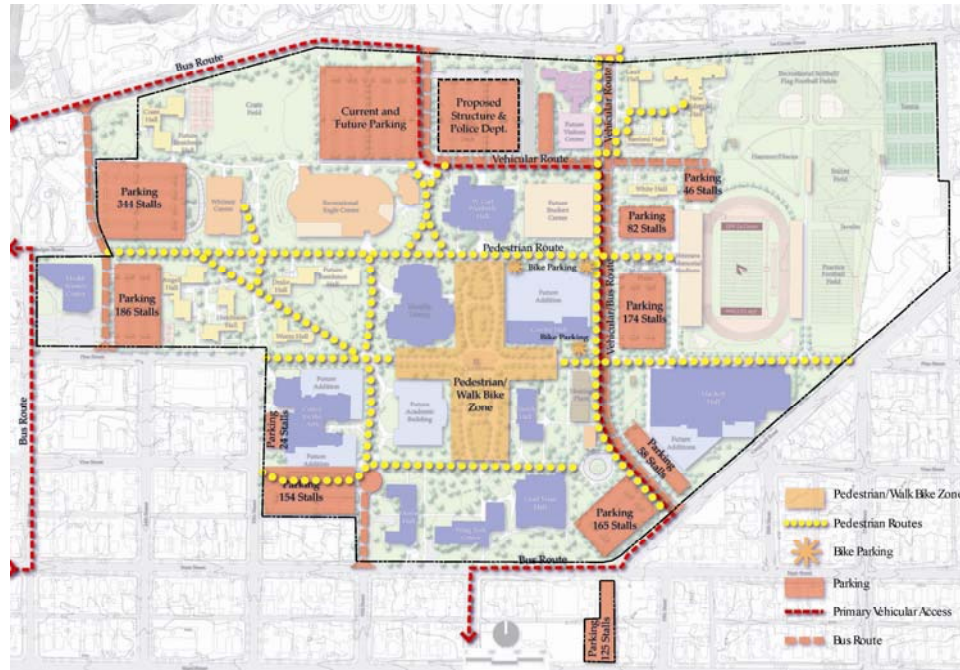

Transportation/Circulation

sides that do not directly front the Central Campus Mall area. These areas should be concentrated where highest traffic counts are anticipated. These areas are likely to include the northeast and northwest project site corners off Badger St., the building frontages on Badger and East, and the southeast building corner. The intent is to encourage bicycle and moped riders to use vehicular based routes for conveyance and then collect them in logical locations and transition to pedestrian transportation.

3.3.3 Pedestrian Access

The UWL Campus remains largely a pedestrian oriented campus in parallel with a principle of the Master Plan to create a more walkable campus environment. The infill on this site in conjunction with the new Student Union Center will greatly increase the pedestrian nature of in this region of campus. In addition, the concentration of civilian parking created by the proposed parking structure away from the academic core and project site will strengthen the pedestrian orientation of Campus. The connections created by these new projects will further strengthen the pedestrian activity on Badger St. and should encourage the development of the pedestrian corridor. All walks should be designed to the minimums as defined in the Campus Master Plan but should be evaluated based on anticipated traffic volume, especially in light of upcoming Campus changes stated.



Transportation/Circulation

3.4 Existing Building Assessment

3.4.1 Overview

Existing Cowley Hall is a 180,000 square foot, four-story building, with a full basement and fifth floor mechanical penthouse. The building was originally built in 1963 with additions to the northwest and east in 1968. The existing structure is an L-shaped building elongated in an east-west direction with north and south orientations. The north and south façade's are primarily glazed curtainwall systems with vertical concrete columns, while the additions to the east and west are brick veneer over a concrete masonry back-up system. The west end of the building aligns the east edge of the northern half of the future campus mall. See 3.1 for an overview of the site and the affects of the future campus mall. A parking lot of 180 spaces is located to the north of the building while a utility corridor is located along the north, south, east, and west edges of the site. These corridors contain steam and chilled water services as well as power, signal, and city water and sewer.



Numerous classroom, laboratory, and mechanical renovations have occurred over the past 47 years, including the following:

Original Building:	1963
Building Addition:	1968
Remodeling:	1976
Roof Replacement:	1987
Elevator Upgrade:	1996
Roof Replacement:	2002
Vestibule Construction:	2004
Fire Alarm System:	2005

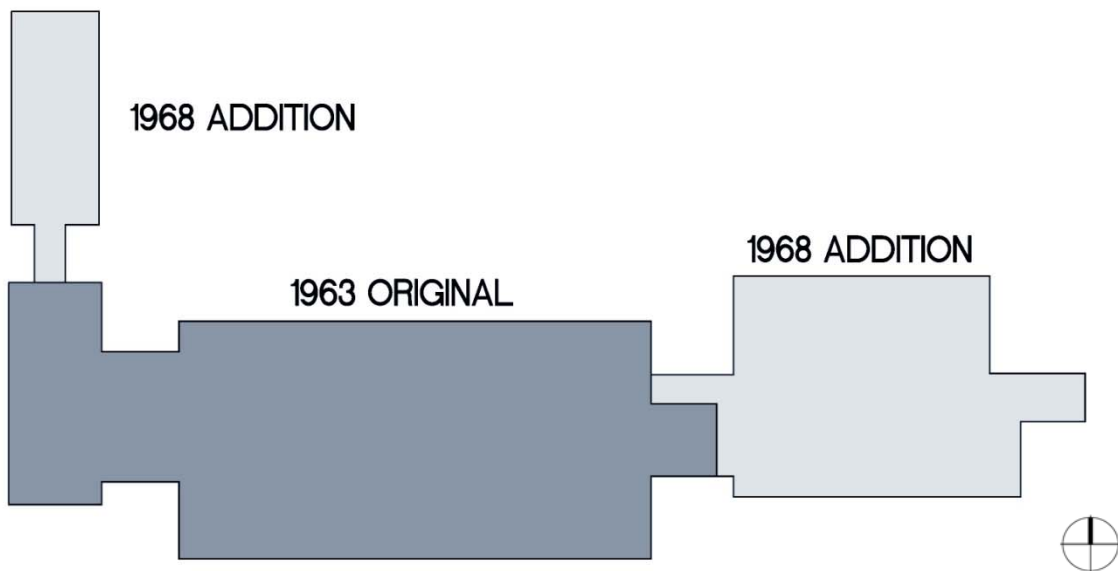

The Existing Building Assessment conducted by this consulting team provides a summary of the existing conditions of Cowley Hall in order to determine if the existing structure can or should be reused. The Existing Building Assessment is divided into Structural, Interior, Mechanical, Electrical, and Plumbing, and Exterior Envelope. This assessment represents the Pre-Design Study teams professional opinion based upon information currently available. This assessment is based upon the tasks outlined in the scope of work requested by the State of Wisconsin, Department of Administration, Division of State Facilities. Further testing, assessment, or demolition, may uncover conditions that would make it necessary to modify our conclusions and recommendations.

3.4.2 Existing Floor Plans

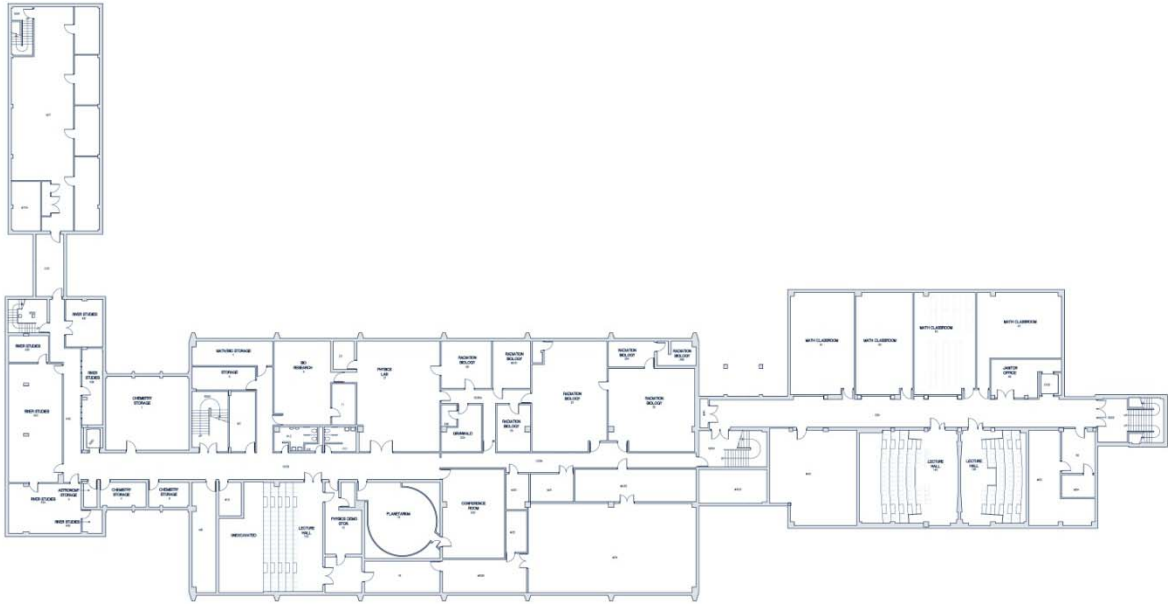

Level 0

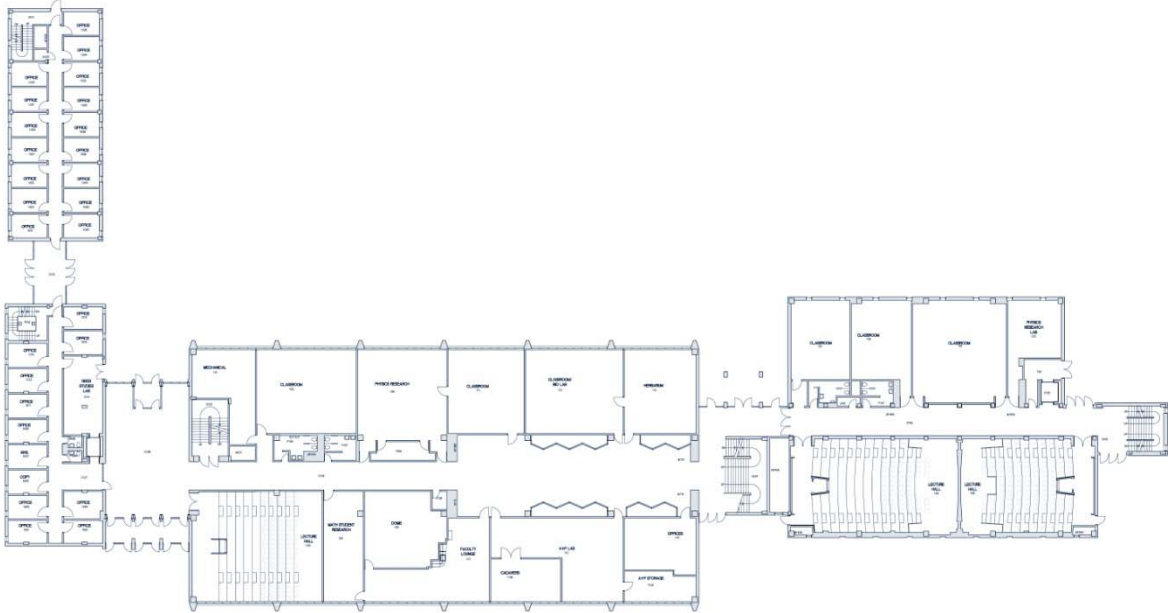

Level 1



Division 3: Physical Planning Issues

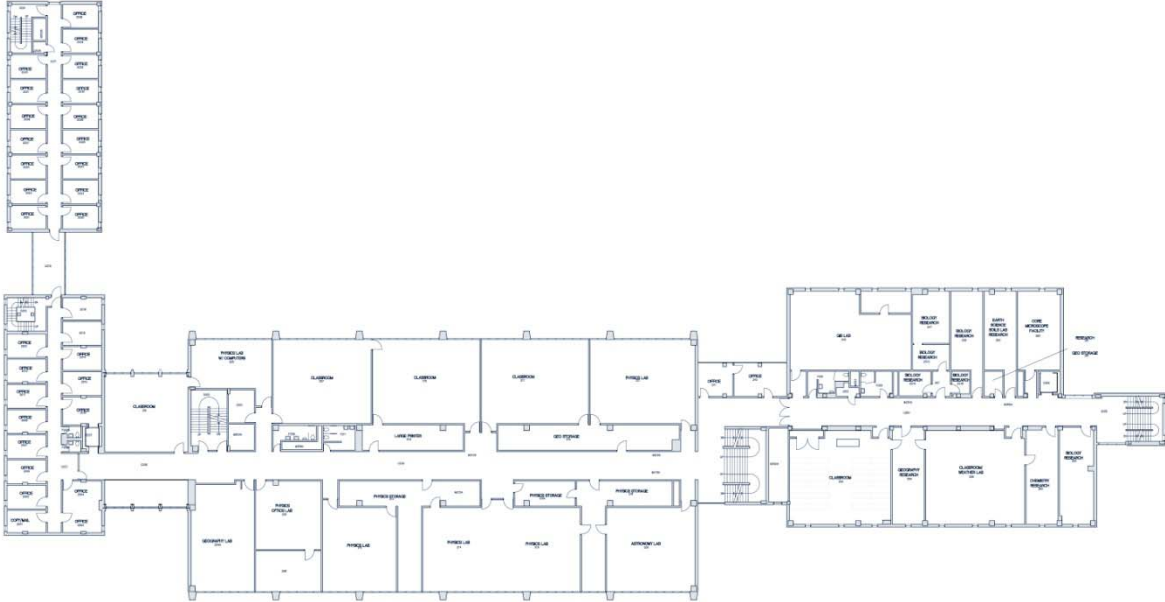

Level 2

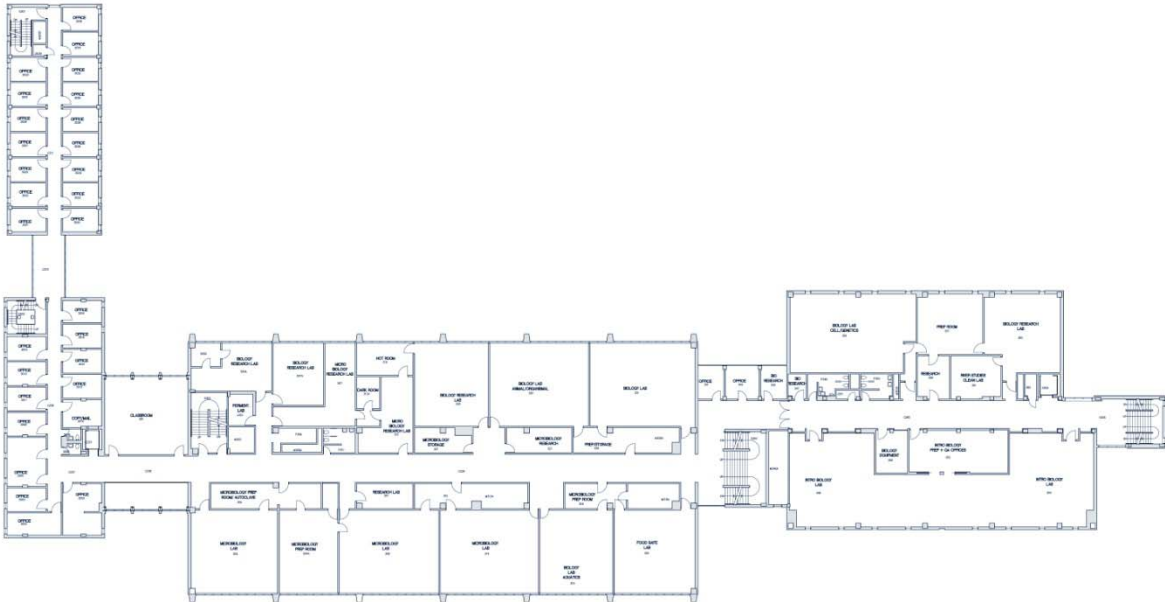

Level 3



Division 3: Physical Planning Issues

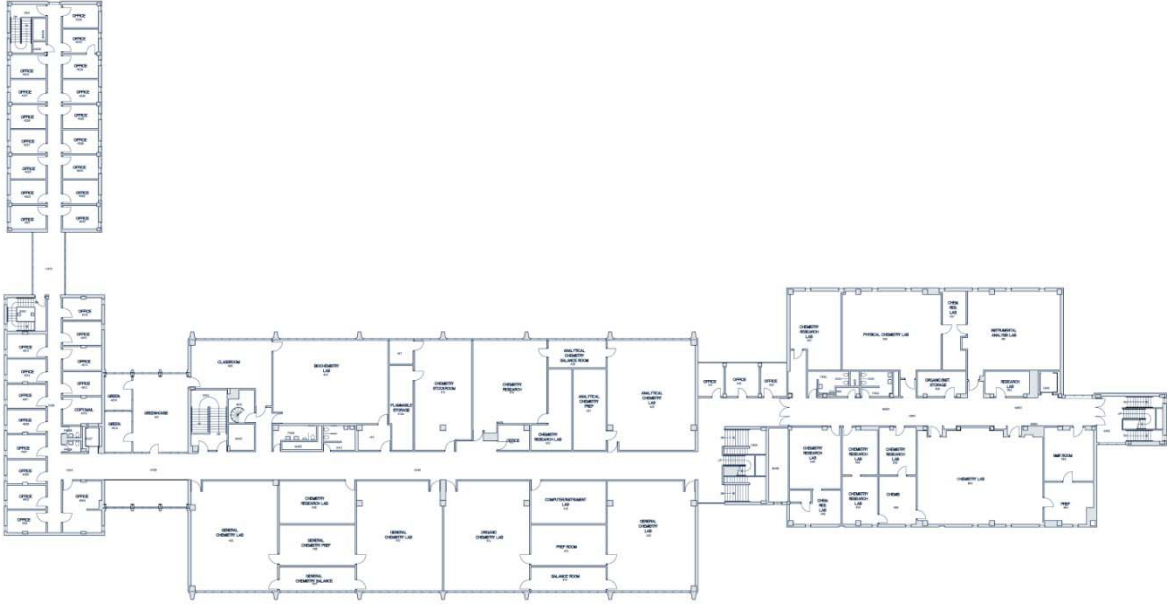

Level 4

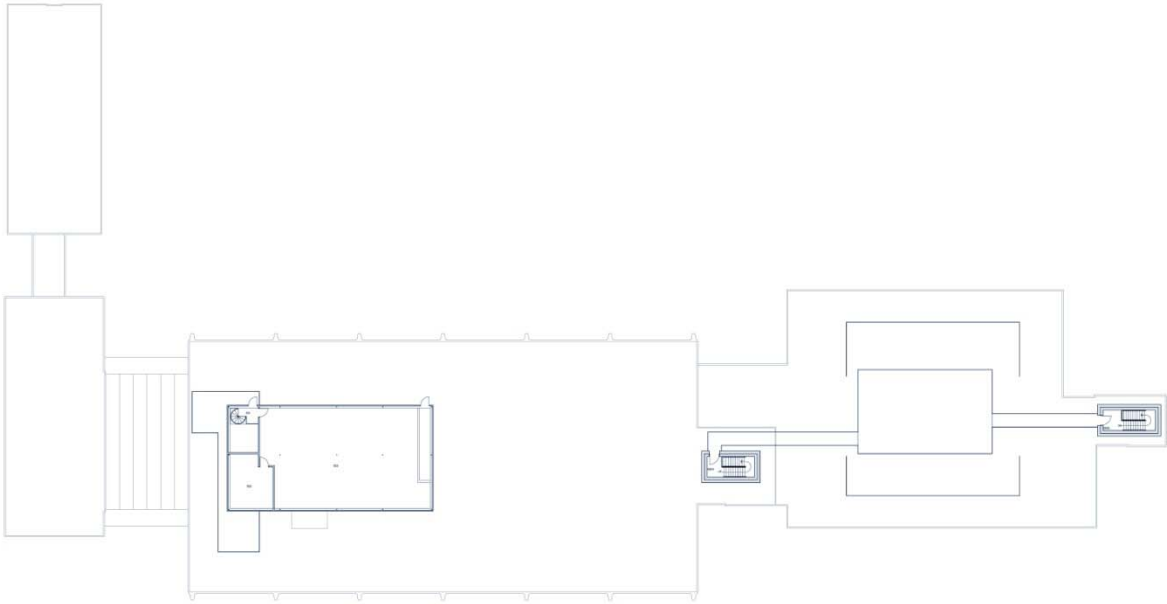

Level 5



Division 3: Physical Planning Issues

3.4.3 Structure

The structural systems within the existing Cowley Hall are made up of concrete columns, beams, floors, and roofs. The structural bay spacing within the existing building range from 18' x 31'-6" at the northwest office wing, 18' x 21' at the west office wing, 30' x 31' at the central portion, and 24' x 34' and 24' x 38' at the east addition. The 1963 building floor system is a two way cast-in-place concrete waffle slab. The domes are 30" x 30" x 14" high with 6" ribs. The slab is 3" thick which results in a 17" deep floor system. The 1968 addition building floor system is a one way concrete joist and beam system. The concrete joists are 6" wide at 3'-0" on center with a 16" pan height and 4" slab resulting in a structure depth of 20". The existing clear height from floor to the underside of the floor structure throughout the building is 10'-6".

The foundation system is spread footings bearing on soil improved by vibrocompaction resulting in an allowable bearing capacity of 7,000 pounds per square foot..

A visual assessment from the interior of the existing structure was conducted and it appears to be in good condition. Concrete floor slabs, columns, and beams have no signs of deterioration, with the exception of the columns noted in Section 3.4.4.4.

Structural Design Load Information		
Item/Description	Original 1963 Building Design Criteria	IBC Table 1607.1 Design Criteria
Classroom Labs	50 psf	50 psf
Lobby, Corridor	80 psf	100 psf - First Floor 80 psf – Corridors above First Floor
Stairs	80 psf	100 psf
Partitions	20 psf	15 psf min.
Roof Load	80 psf	40 psf ground snow load
Allowable Soil Bearing	7,000 ksf	-----

Division 3: Physical Planning Issues

3.4.4 Exterior Envelope

3.4.4.1 General Description

The exterior envelope at the original 1963 core of the existing Cowley Hall consists of a minimally insulated wall with a glazed curtainwall system within a concrete frame. The vertical ribs are exposed concrete columns cast in an architectural precast form. The east and west additions are primarily brick veneer over concrete masonry.



East Addition



Central Core



West Addition

3.4.4.2 Entrances

There are three primary entrance areas to Cowley Hall. The three entrances on the north side of the building serve the parking lot while the entrances to the south and west serve high traffic areas from adjacent academic buildings.

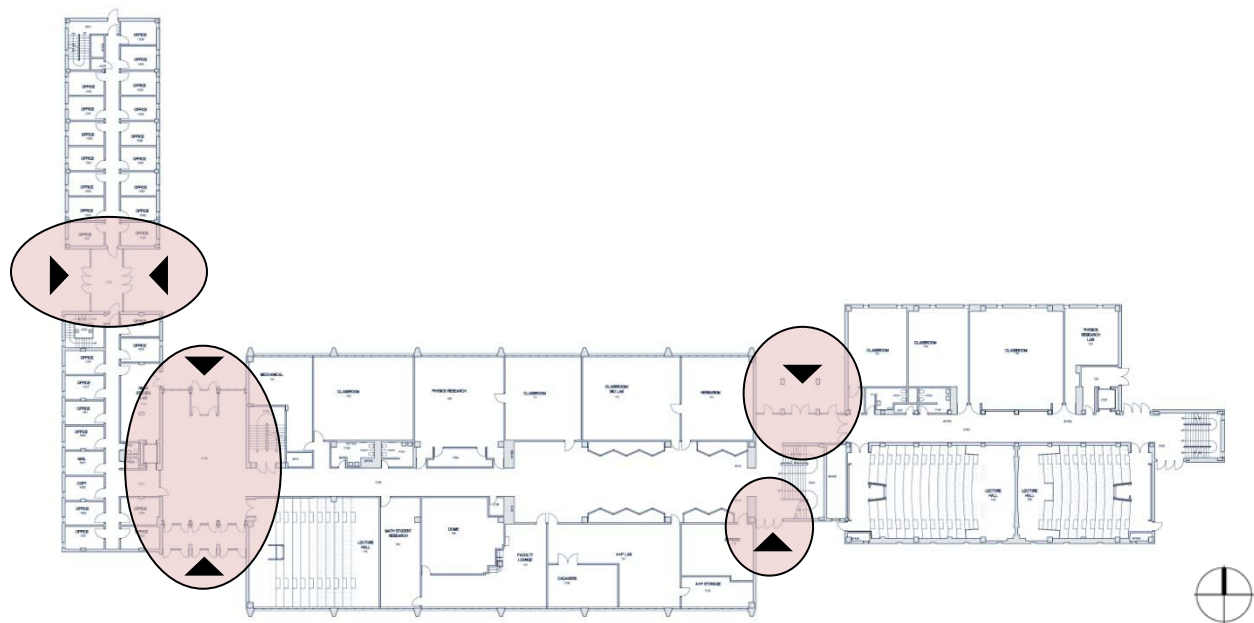

The entrances at the southwest link were renovated in 2004 and incorporated new vestibules with sloped roofs. These entrances appear to be in good condition.

Division 3: Physical Planning Issues

3.4.4.3 Windows & Doors

The existing windows are original to the building and are constructed of aluminum non-thermally broken frames with ¾" glazing. In order to enhance energy performance, it is recommended to replace the existing windows with thermally broken aluminum frames and 1" thick, high-performance glazing.

The existing building's window to wall ratio was compared to DSF Daylighting Standards. The following chart shows the comparison:

ORIENTATION	GLAZING	WALL	%	DSF ACCEPTABLE	DSF PREFERRED
North	6,352 SF	21,792 SF	29%	70%	50%
South	5,328 SF	20,592 SF	26%	30%	26%
East	1,600 SF	13,536 SF	12%	30%	22%
West	1,664 SF	13,392 SF	12%	30%	22%

The existing curtainwall system at the original 1963 portion of the building has failed during storm events and allowed water to infiltrate the building.



3.4.4.4 Masonry

Although the brick veneer is over 40 years old, it appears to be in good condition. No visual cracking or deterioration of the brick veneer is present.

While weep vents are spaced 32" apart, there appears to be no metal flashing present at the base of the wall or at the shelf angles. Original drawings indicate plastic flashing being used at the base of the wall, but there is no drip extension present.

There appears to be cracking in the exterior face of the concrete column precast formliners on the north and south elevations. Further investigation is needed in order to determine if this is a structural failure in progress or if it is a failure of the outer concrete veneer.

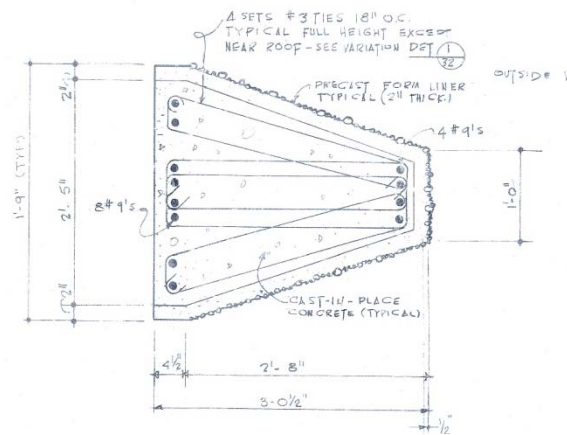
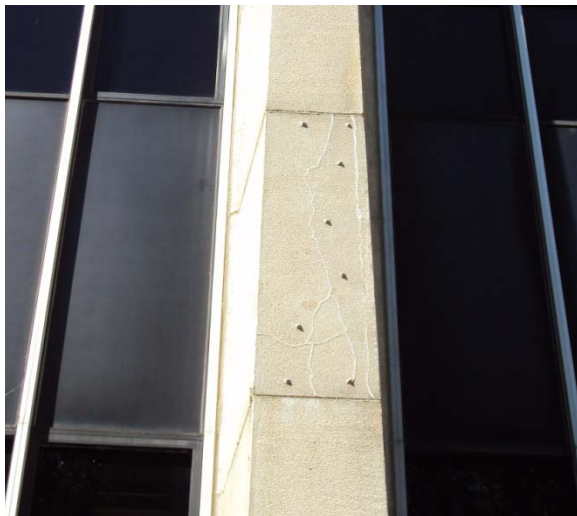

In the event of a major renovation, all caulking should be cleaned and reinstalled. Tuckpointing and washing of the existing brick veneer should also be considered part of a renovation project.

Division 3: Physical Planning Issues

3.4.4.5 Roofing

The roof was replaced in 2002. According to the construction documents for that project, the roof system consists of a 45 mil EPDM membrane with gravel ballast over 5 ½" of insulation board.



Photo of observation platform

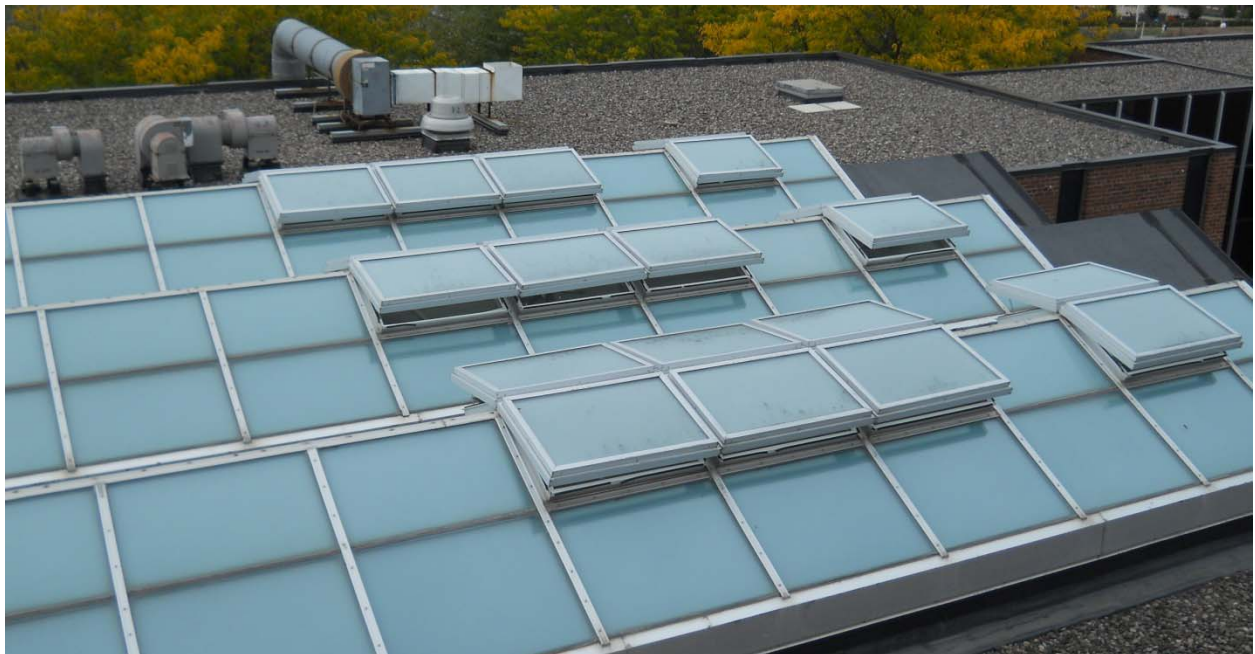

From the interior, previous leaking of the skylights over the fourth floor greenhouse area is visible. Because the Campus Master Plan calls for removal of the western portion of existing Cowley Hall, this entry and skylight area would be removed as part of a renovation project.



Photo above shows mechanical louvers located at the roof level. In order to prevent snow infiltration, this louver should be raised a minimum of 3'-0" above the roof.

3.4.4.6 Thermal Performance

According to the original building construction drawings, insulation does not appear to be present in the masonry construction on the west end of the building. The metal curtainwall system on the north and south sides consists of 1" thick insulated spandrel panels and ¼" thick glazing provide minimal insulation. The drawings also indicate a ½" fiberboard and damproofing being used at the foundation walls.

The existing building's envelope performance was analyzed using the Department of Energy's COMcheck software and the outcome of the analysis shows that the existing Cowley Hall will not meet the 2006 International Building Code, the current code in place at the time of this study.

3.4.5 Interior

3.4.5.1 Interior Finishes

The interior finishes of existing Cowley Hall include concrete masonry partitions, asbestos floor tile, exposed concrete structural slabs, glazed ceramic concrete masonry in the corridors, hollow metal door frames, wood doors, and acoustical ceiling tile. Faculty offices and corridors typically have acoustical ceilings while teaching labs have exposed structural systems. The asbestos containing floor tiles in the west office wing are in poor condition. The floor and ceiling tile in the east wing corridors are also in poor condition.



Division 3: Physical Planning Issues

3.4.5.2 Restrooms

The restrooms within Cowley Hall appear to be original to the building and show no signs of alternations. The 28" doors along with limited floor area, result in layouts that are inaccessible for those with physical challenges. Clearances at the pull and push sides of the restroom doors are inadequate to meet current standards. Most of the restrooms are also not equipped with accessible stalls.

3.4.5.3 Stairs

Constructed with steel stringers and risers, the concrete stair runs appear to be in good condition physically. While the tile treads are durable, they offer no slip resistance or visual demarcation of the nosing. Handrails are 28" above stair nosings and have no extensions at the top or bottom of the stair runs.

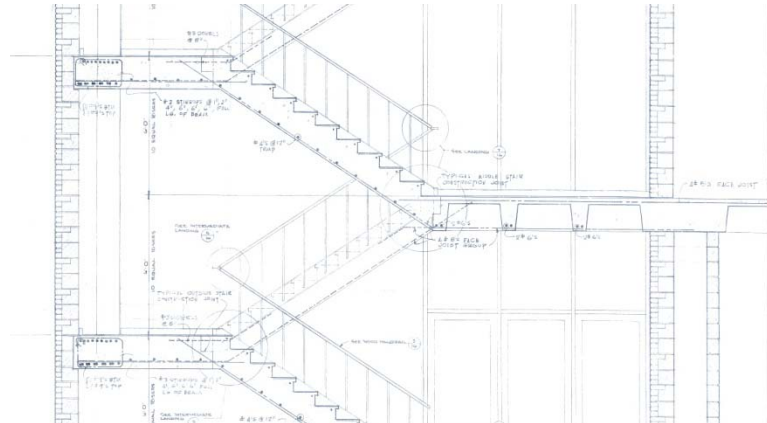

3.4.5.4 Elevators

A passenger elevator is currently located in the west end of the original building and a freight elevator is located in the east addition.

The passenger elevator will be removed with the west office wing demolition.

3.4.6 Mechanical, Electrical and Plumbing Systems

The mechanical systems infrastructure is unworthy of reuse in the existing Cowley Hall. All systems are well beyond their useful life expectancies and are not appropriate to meet the needs of a modern university building. The floor to floor height of twelve feet results in a dimension of about ten feet from the floor to the underside of the structure. Today's modern classroom buildings have minimum nine foot ceilings, with many programmed for ten feet. Even with eight foot ceilings the resulting ceiling space is inadequate for today's HVAC, plumbing, electrical and data systems to fit into. Long term, the result of forcing these infrastructure systems into such a tight space will create energy inefficiencies, make maintenance more difficult, and make future system modifications difficult of even impossible.

3.4.6.1 Mechanical, Electrical and Plumbing Infrastructure Impact of the West Office Wing

Mechanical – Chilled water and steam service is fed from the main building so regardless whether the building is reused or new, temporary services will have to be provided to keep that building in operation.

Plumbing – The west office building is served with dedicated sanitary and storm water mains, however domestic water and hot water is fed from the existing Cowley Hall. Temporary services will need to be provided.

Electrical – Two substations are provided for the building. The smaller (500Kva) substation was installed for air conditioning. We understand the substation is no longer being used for the air conditions system. The remaining substation (750Kva) provides power for the remaining building. Either substation may remain for temporary construction power. We are recommending that new unit substation be installed in a new location to serve the remodeled building.

Information Technology - Drawings of internal telecom wiring were not provided. But because the site plan indicates the campus demarcation point within the main building, it must be assumed that the west wing is serviced from the main demarcation point. If the main building were to be demolished, temporary campus services would need to be provided to the west wing, probably from existing signal MH 40.

Division 3: Physical Planning Issues

3.4.7 Building Reuse Considerations

Structural

Structurally, the existing Cowley Hall appears to be in very stable condition. The original building loading criteria will accommodate today's minimum building code requirements. However, the structural load and performance requirements will not allow the reinstatement of teaching laboratory spaces without significant structural upgrades. The departmental offices are better suited for the bay spacing and structural capacity provided. The current program option of department offices and classrooms in the existing structure is acceptable per minimum building code requirements.

The existing concrete waffle slab thickness in the 1963 building is 3" and will not meet the 1 hour floor assembly requirement for this type of structure. As a result the existing floor slabs will need to be treated with fireproofing material.

The floor to floor height of 12'-0" with a clear height of 10'-6" will not provide efficient routing of mechanical, plumbing, and electrical systems. With a typical interstitial space requirement of even 3'-0" ceiling heights would be limited to 7'-6". An extreme mechanical system design will be needed to minimize the size of horizontal ducts in order to reduce the interstitial space above the ceiling, which results in additional vertical duct chases which will compromise usable square footage within the building. Vertical duct chases in the existing waffle slab will be limited to certain areas unless additional reinforcing and supports are provided.

Interiors

Although the interior finishes are very durable, they are outdated. Asbestos containing floor tile will need to be removed as part of a major renovation project. It is likely that a renovation project would require the removal of most, if not all the interior partitions in order to accommodate the program requirements of the project. Restrooms will need to be completely demolished and reconstructed and should incorporate reduced water usage fixtures and be completely ADA accessible. The existing stairs are in very good condition but need to be updated to today's building code requirements. Handrails and guardrails need to be code compliant and should incorporate durable materials in order to handle high usage. Slip-resistant treads should be provided at all stairs.

Mechanical, Electrical, and Plumbing

The mechanical systems infrastructure is unworthy of reuse in the existing Cowley Hall. All systems are well beyond their useful life expectancies and are not appropriate to meet the needs of a modern university building. Further, the existing building structure has a floor to floor height of just 12 feet, and the program for most spaces list minimum ceiling height of 9'-0" or 10'-0". This results in available ceiling space of only 6" to 18" for mechanical, electrical and plumbing services. A typical university building built today would require a three to four foot interstitial space to contain the HVAC ductwork, piping, and terminal units, along with plumbing piping services, electrical conduits and lighting, and other systems such as data cable trays.

In order to accommodate these services in a building such as this, many compromises must be made, many of which would not be in accordance with DSF standards. Most ceilings would have to be at eight feet vs. the preferred minimum height of nine to ten feet per the space program. Mechanically, ductwork would have an excessive number of fittings resulting in higher pressure drop and resulting fan energy consumption. Piping systems would need to be run over classrooms and terminal units would all be located above classroom ceilings. Service access to equipment and devices would be difficult and not in ideal locations. The need to minimize ductwork sizes will require either the addition of more vertical shafts or a more extreme approach of adding multiple vertical shafts to the exterior of the building. The use of a chilled beam concept will still require the above design efforts in order to work. These issues have been reflected in the cost estimate and contributed to the reason the cost is higher than new construction.

Exterior Envelope

The central core of existing Cowley Hall is most likely to remain in the event of a major renovation/addition type of project and repurposed into departmental offices. The curtainwall systems on the north and south sides will need to be replaced at a minimum with a thermally broken framing system and high performance glazing. An alternative approach would be to remove the curtainwall system and replace it with a masonry cavity wall system.

Although the east addition's exterior is a cavity wall system with insulation, it is minimal by today's standards. In order to increase the thermal performance of the exterior wall, insulation would likely need to be added to the interior side of the building.

The following wall section diagrams show possible strategies for enhancing the performance of the existing Cowley Hall exterior envelope. Upon review of the existing drawings, portions of the building are more insulated than others and as result are treated differently. Further analysis will need to be conducted based on the energy code in place at the time of design submittal.

1963 BUILDING WALL SECTION DIAGRAM

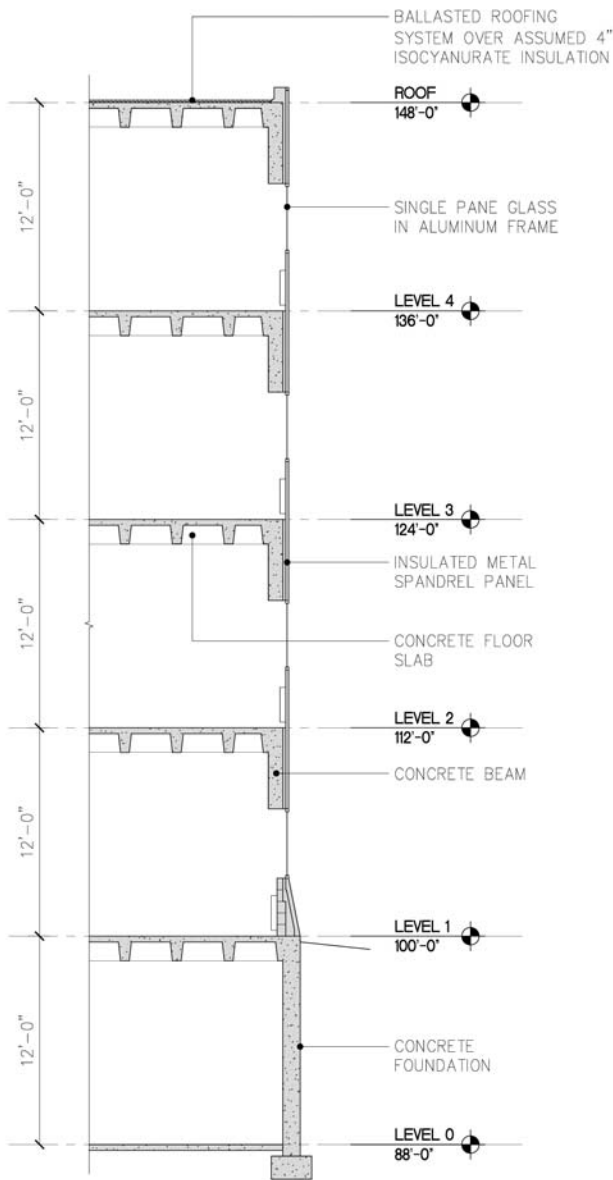

Existing Wall Section

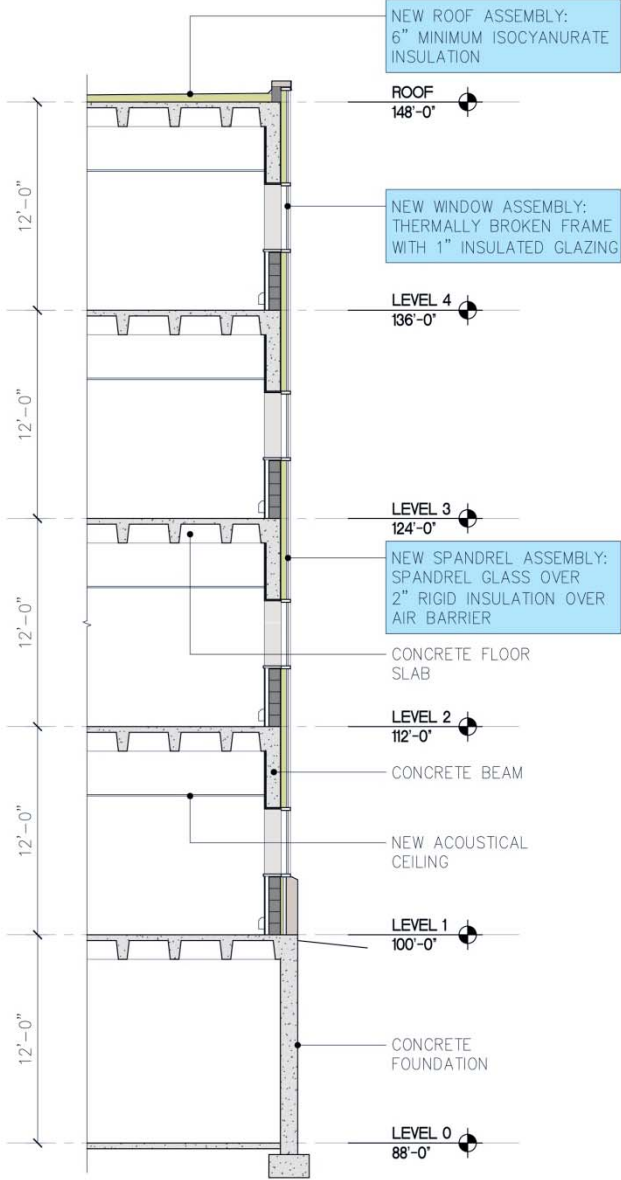

Proposed Wall Section – Option A

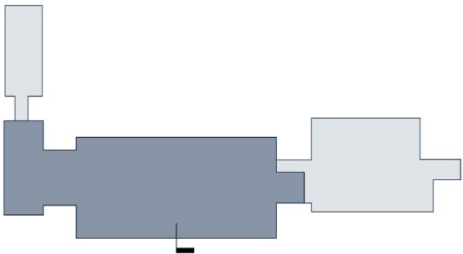

Key Plan



Description:
 Remove existing curtainwall system and replace with concrete masonry back-up, air barrier, insulation, and a high performing curtainwall system while maintaining the architecture of the glazed wall with metal spandrel panels.

1963 BUILDING WALL SECTION DIAGRAM

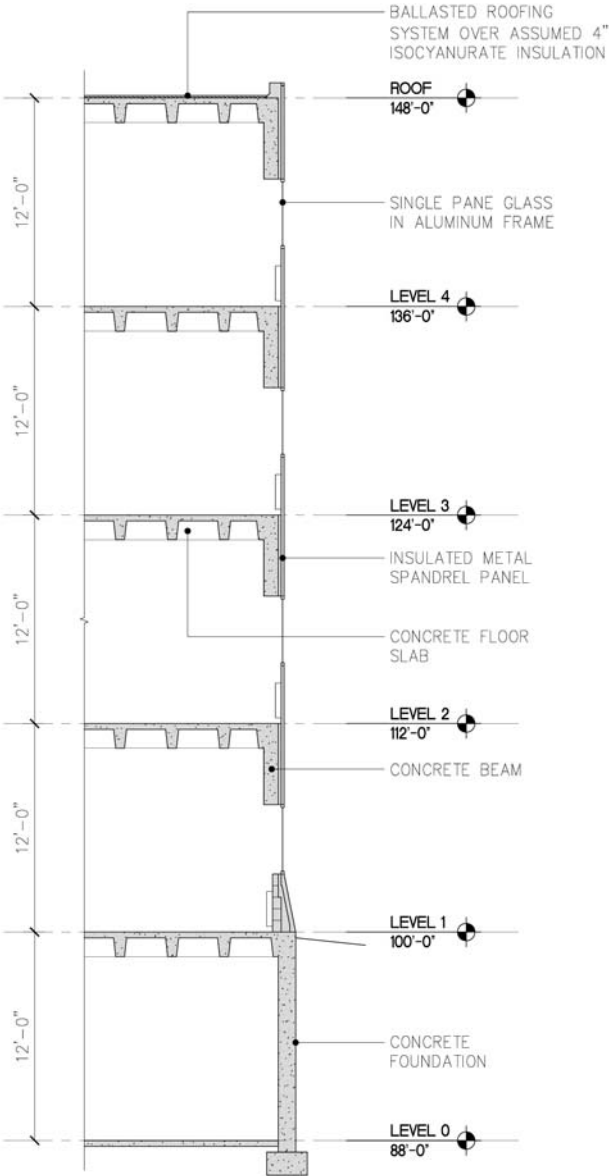

Existing Wall Section

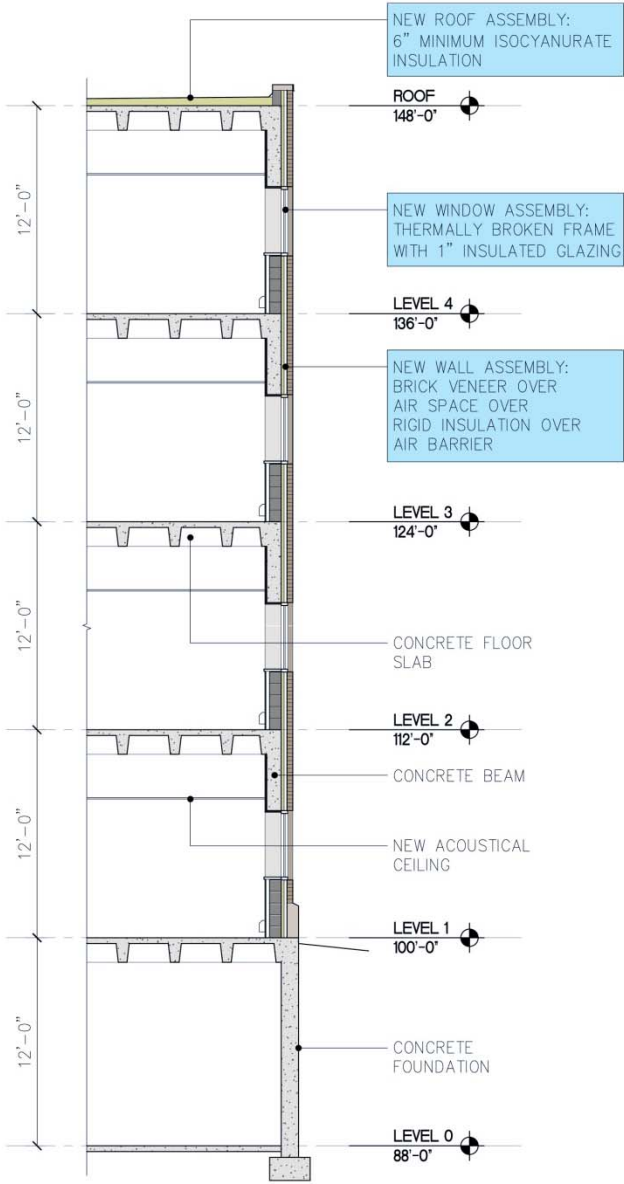

Proposed Wall Section – Option B

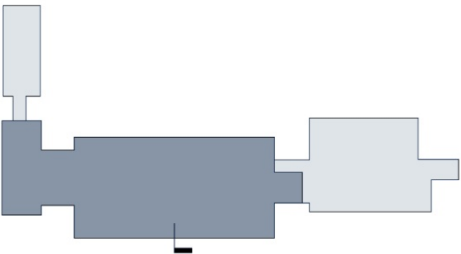

Key Plan



Description:
 Remove existing curtainwall system and replace with concrete masonry back-up and DSF rainscreen wall construction with an air barrier, insulation, and brick veneer.

1963 BUILDING WALL SECTION DIAGRAM

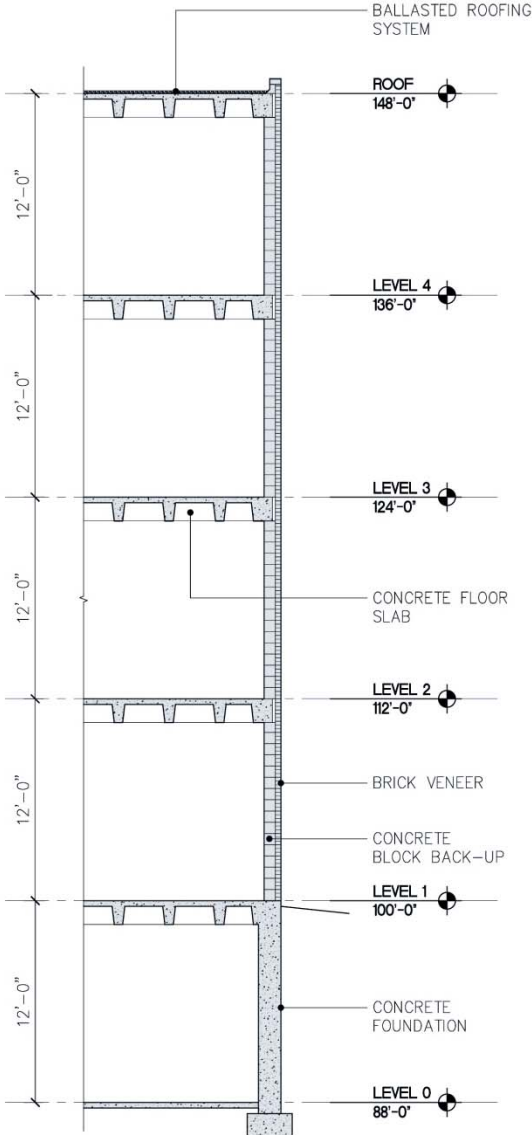

Existing Wall Section

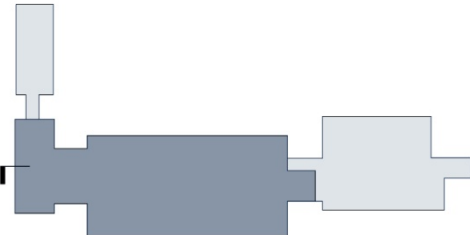

Description:
 Since this portion of the building is to be removed as described in the Campus Master Plan, the Pre-Design Team did not provide a strategy to enhance the exterior wall construction.

Key Plan

1968 BUILDING WALL SECTION DIAGRAM

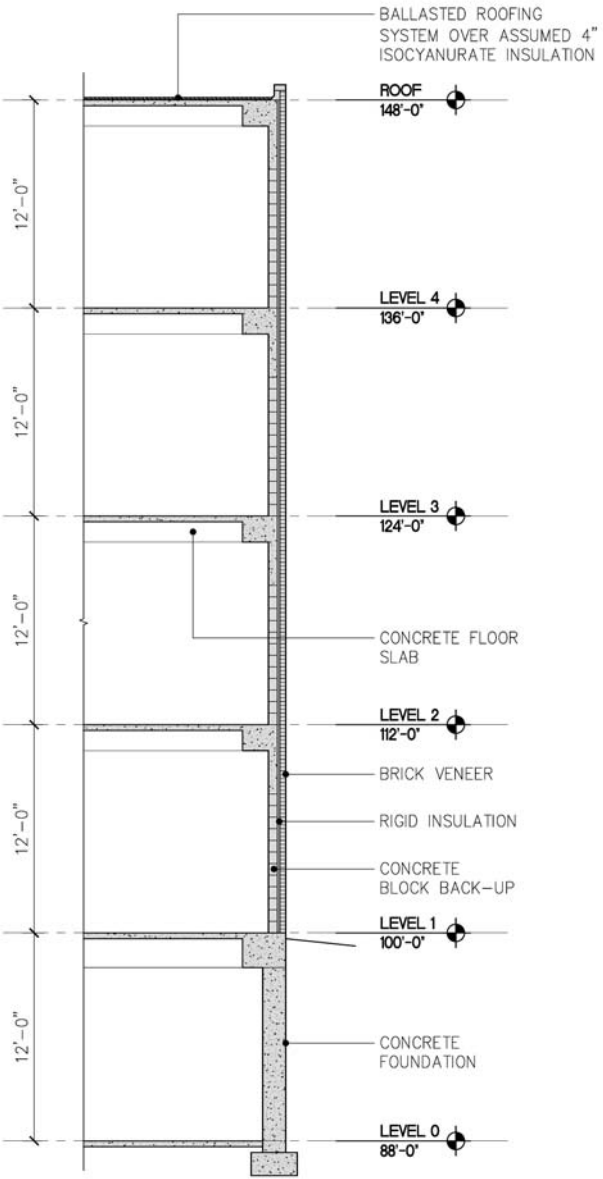

Existing Wall Section

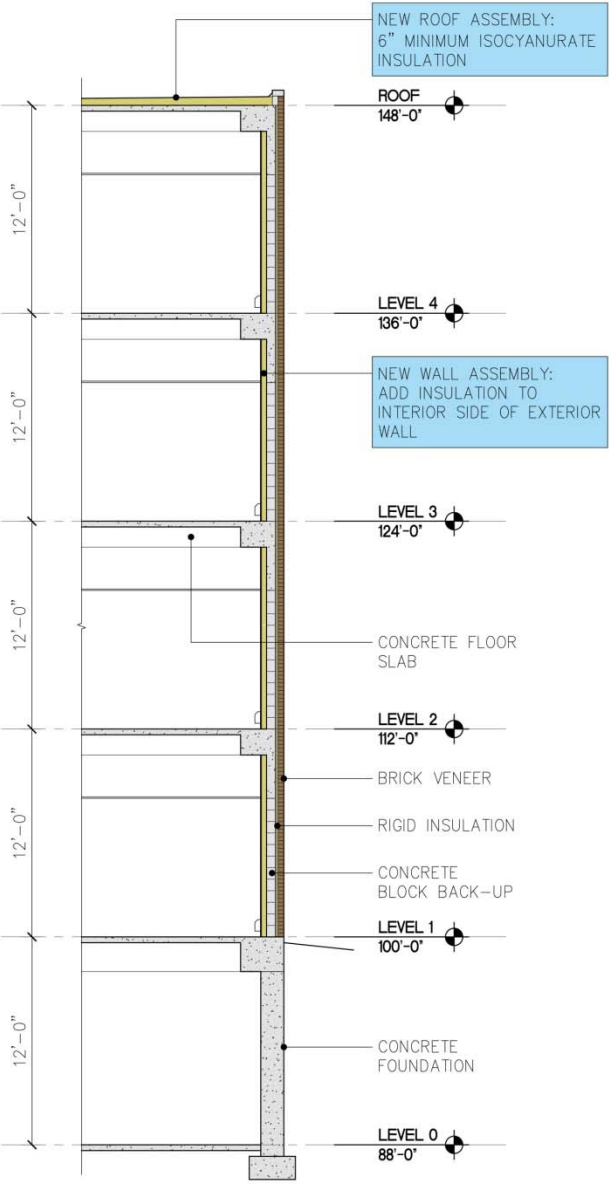

Proposed Wall Section – Option B

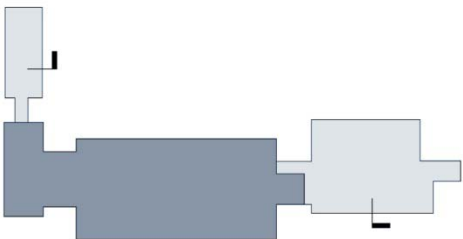

Key Plan



Description:
 The existing drawings of this addition indicate insulation is present within the exterior wall. With a thermal break and drainage plain, additional insulation would be provided at the interior side of the wall to increase envelop performance.

Division 4: Special Planning Issues

4.1 Environmental Impact

In accordance with the Wisconsin Environmental Policy Act (WEPA), this project will require an Environmental Impact Statement (EIS). This requirement ensures that all fiscal impacts raised during the WEPA process will be addressed in the project budget estimate. The entire WEPA process must be completed prior to bid solicitation.

Signed into law in 1972, WEPA spells out the state's environmental policy and requires state agencies to consider the environmental effects of their actions to the extent possible under their other statutory authorities. It also establishes the principle that broad citizen participation should be part of environmental decision-making. WEPA imposes procedural and analytical responsibilities on the agencies but does not provide authority to protect the environment.

DSF will select, hire, and monitor the work of the EIS consultant.

4.2 Zoning Requirements

The site is zoned Public/Semi-Public and will not need to be rezoned.

4.3 Accessibility Requirements

An important goal for the Cowley Hall Science Building is to create an accessible environment for all users. The building will comply with applicable state and federal codes, DSF Accessibility Guidelines, and other applicable standards for accessibility. The design team is encouraged to incorporate a holistic approach to seamlessly integrate architectural solutions that address accessibility with dignity to the widest range of users. There are seven governing principles that enable this process;

1. *Equitable:* Make design appealing and provide the same means of use for all users.
2. *Flexibility:* Accommodate a wide range of individual preferences.
3. *Simplicity:* Use of design is easy to understand.
4. *Perceptible Information:* Communicate necessary information to the user.
5. *Tolerance for Error:* Provide safe features throughout.
6. *Effortless Use:* Allow users to maintain neutral body positions and perform tasks with reasonable force.
7. *Size/Space for Approach and Use:* Provide space for approach, reach, and use regardless of users abilities.

Universal Design comes from incorporating these guideline principles into underlying design thinking. There are no specific goals to reach; there is instead a framework for creating resourceful solutions.

4.3.1 Laboratory Accessibility Guidelines

Accessible work stations and fume hoods should be provided in the laboratories based on code requirements.

Location of accessible work stations as close as possible to eyewash and safety showers.

Some general criteria and guidelines for accessible work stations in laboratories are as follows:

Work surfaces 30" - 34" above floor with wheelchair clearance below. Adjustable work surfaces can provide a range of possible height adjustments.

Laboratory service controls, equipment, and equipment controls within easy reach for persons with limited mobility. Controls should have single-action levers or blade handles for easy operation.

Aisle widths and clearances adequate for maneuvers of wheelchair bound individuals. Aisles 5'-0" wide are recommended with turnaround areas.

4.4 Sustainable Facilities and Energy Conservation

The intent is to create a high environmental performance project that has low operating costs, healthful indoor environments, and low environmental impact. These environmental goals will be integrated into the design strategies for form, function, schedule, and budget.

The design will incorporate sustainable design principles that are sensible and valid, especially those with an emphasis on energy efficiency and long term durability.

4.4.1 Division of State Facilities

The Division of State Facilities (DSF) is committed to sustainable design to promote the environmental and economic benefits of energy conservation in the planning, design, construction, and operation of state facilities. DSF has implemented policies to reduce energy consumption in state facilities without adversely affecting program operations.

Recognizing that the greatest cost of owning state facilities over their lifetime is the cost of energy to heat, cool, light, and operate them, DSF expects the design of every project to:

- Achieve the highest energy efficiency and lowest energy consumption that life-cycle costing will justify;
- Incorporate the most energy-efficient materials, products, equipment, and systems consistent with program and budget;
- Incorporate renewable energy technologies at the earliest possible stages of design whenever they are technically and economically feasible;
- Consider the impact on the utility infrastructure of the existing facility.
- Select environmentally responsible materials and products with reduced maintenance required

4.4.2 Integrated Design Process

DSF expects the A/E to follow an “integrated design approach” on every project. This means that architectural, mechanical, and electrical systems are designed as parts of a whole building/energy system. The architect will consider HVAC and electrical loads in making fundamental decisions about the basic building concept and architectural form: e.g. orientation, massing, treatment of façade, fenestration, interior surfaces and lighting. All architectural decisions are evaluated for how they affect the heating, cooling, and electrical lighting loads of the building. This process requires greater involvement of mechanical and electrical engineers at the earliest stages of design, building energy modeling during conceptual and working design phases and it requires strong energy conservation advocacy and commitment from the prime A/E.

4.4.3 Building Energy Modeling

Building energy modeling is required for new structures, new additions and remodels greater than 20,000 GSF with the exception of utilitarian buildings and remodels which do not replace mechanical/electrical systems and reconfigure the building shell. In addition, building modeling is required for all new buildings to demonstrate that the annual building energy cost is 30% less than a code designed base building, based on the code in effect at the time of design.

The code designed base building comparison must be based on the Total Building Performance method included in Commerce 63/IECC 2009. Alternatively the base building and comparison may be based on ASHRAE Standard 90.1-2007 Building Performance Rating Method.

During schematic design, the A/E shall use integrated design to determine the most energy efficient building configurations and systems. The A/E shall develop multiple building design concept options and/or multiple building envelope options, mechanical system options, lighting system options, and plumbing system options. Building energy modeling will be performed to compare these options.

The building energy modeling used to compare building/system options and used to demonstrate the 30% better than code requirement must utilize a computer based program for the analysis of energy consumption in buildings.

The A/E shall report the modeled energy consumption and code comparison results in the Energy Performance Report portion of the Design Report.

Division 4: Special Planning Issues

For all new buildings, structures, additions and major remodeling projects, the A/E shall use life cycle cost analysis to evaluate all relevant costs for each building alternative.

4.4.4 Renewable Energy Sources:

The Division of State Facilities expects all projects to make maximum practical and economic use of passive solar energy and daylighting. The design of all state facilities will, to the fullest extent possible, incorporate natural lighting, to replace the need for electric lighting during daytime hours. Use geothermal technologies for space and water heating systems where technically feasible and cost effective.

Projects with a total budget exceeding \$500,000 are expected to make maximum practical use of active solar heating and renewable electric generation from solar thermal or photovoltaic systems, wind power, geothermal technology, biomass, fuel cells using renewable fuel or tidal or wave action and small hydro, *when technically and economically feasible*. In the Design Report the A/E shall state what consideration was given to these renewable energy systems.

4.4.5 Design Guidelines:

- Energy Design Guideline
- Sustainable Facilities Guideline
- Daylighting Standards for State Facilities
- Lighting Design Guidelines
- LEED® Silver Certification

4.4.6 Sustainable Facilities and Energy Conservation

UW-La Crosse is committed to becoming a campus that values sustainability. It is a goal of this project to provide a high performance building following the guidelines outlined by the U.S. Green Building Council in order to achieve LEED® Silver Certification. The DSF Sustainable Facilities Standards should also be followed closely throughout the project. It is a goal of the University to emphasize energy efficiency, future maintainability and flexibility, and long term durability. The concept design included in the Pre-Design Study emphasizes the use of natural daylight into all occupied spaces, reducing the need for artificial lighting, thus decreasing energy usage. Systems described in the Pre-Design Study outline those mechanical functions (HVAC, lighting, stormwater management, etc.) that will assist in achieving the goals outlined above. The use of local, renewable, and recycled materials should be considered wherever possible. Sustainability can be divided into the following key subjects: Sustainable Sites, Water Efficiency, Energy and Atmosphere, Materials and Resources, Indoor Air Quality and Innovation and Design.

The following narrative descriptions provide a summary of the credits available in the LEED rating system.

Sustainable Sites (SS)

SSW1 - Construction Site Erosion & Sedimentation Control

Intent: To reduce pollution from construction activities by controlling soil erosion, waterway sediment and airborne dust generation.

SS1 - Site Selection

Intent: To avoid the development of inappropriate sites and reduce the environmental impact from the location of a building on a site.

SS2 - Development Density & Community Connectivity

Intent: To channel development to urban areas with existing infrastructure, protect greenfields, and preserve habitat and natural resources.

SS3 - Brownfield Redevelopment

Intent: To rehabilitate damaged sites where development is complicated by environmental contamination and to reduce pressure on undeveloped land.

SS4 - Alternative Transportation

SS4.1 - Public Transportation Access Credit

Intent: To reduce pollution and land development impacts from automobile use.

Division 4: Special Planning Issues

SS4.2 - Bicycle Storage & Changing Rooms Credit

Intent: To reduced pollution and land development impacts from automobile use.

SS4.3 – Low-Emission & Fuel Efficient Vehicles

Intent: To reduce pollution and land development impacts from automobile use.

SS4.4 - Parking Capacity

Intent: To reduce pollution and land development impacts from automobile use.

SS5 - Site Development

SS5.1 - Protect or Restore Habitat

Intent: To conserve existing natural areas and restore damaged areas to provide habitat and promote biodiversity.

SS5.2 - Reduced Site Disturbance: Development Footprint

Intent: To promote biodiversity by providing a high ratio of open space to development footprint.

SS6 - Permanent Stormwater Management

SS6.1 - Discharge Rate and Volume per DNR 151

Intent: To limit disruption of natural hydrology by reducing impervious cover, increasing on-site infiltration, reducing or eliminating pollution from stormwater runoff and eliminating contaminants.

SS6.2 - Permanent Stormwater Design, Quality treatment per DNR 151

Intent: To limit disruption of pollution of natural water flows by managing stormwater runoff.

SS7 - Heat Island Effect

SS7.1 - Non-Roof

Intent: To reduce heat islands to minimize impacts on microclimates and human and wildlife habitats. The heat island effect is the thermal gradient difference between developed and undeveloped areas.

SS7.2 - Roof

Intent: To reduce heat islands to minimize impacts on microclimates and human and wildlife habitats. The heat island effect is the thermal gradient difference between developed and undeveloped areas.

SS8 - Light Pollution Reduction

Intent: To minimize light trespass from the building and site, reduce sky-glow to increase night sky access, improve nighttime visibility through glare reduction and reduce development impact from lighting on nocturnal environments.

Water Efficiency (WE)

WE1 - Water Efficient Landscaping

No Potable Use or No Irrigation

Intent: To limit or eliminate the use of potable water or other natural surface or subsurface resources available on or near the project site for landscape irrigation.

WE2 - Innovative Wastewater Technologies

Intent: To reduce wastewater generation and potable water demand while increasing the local aquifer recharge.

WE3 - Water Use Reduction, 30% - 35% - 40% Reduction

Intent: To further increase water efficiency within buildings to reduce the burden on municipal water supply and wastewater systems.

Energy & Atmosphere (EA)

EAP1 - Building Systems Commissioning

Intent: To verify that the project's energy-related systems are installed, and calibrated to perform according to the owner's project requirements, basis of design, and construction documents. Benefits of commissioning include reduced energy use, lower operating costs, fewer contractor callbacks, better building documentation, improved occupant productivity and verification that the systems perform in accordance with the owner's project requirements.

Division 4: Special Planning Issues

EAP2 - Minimum Energy Performance

Intent: To establish the minimum level of energy efficiency for the proposed building and systems to reduce environmental and economic impacts associated with excessive energy use.

EAP3 - CFC Reduction in HVAC&R Equipment

Intent: To reduce stratospheric ozone depletion.

EA1 - Optimize Energy Performance: For Project > 2 million (1-19 points)

Intent: To achieve increasing levels of energy performance beyond the prerequisite standard to reduce environmental and economic impacts associated with excessive energy usage.

EA2 - Renewable Energy (1% to 13%)

Intent: To encourage and recognize increasing levels of on-site renewable energy self-supply to reduce environmental and economic impacts associated with fossil fuel energy use.

EA3 - Enhanced Commissioning

Intent: To begin the commissioning process early in the design process and execute additional activities after systems performance verification is completed.

EA4 - Enhanced Refrigerant Management

Intent: To reduce ozone depletion and support early compliance with the Montreal Protocol while minimizing direct contributions to climate change.

EA5 - Measurement & Verification Credit

Intent: To provide for the ongoing accountability of building energy consumption over time.

EA6 - Green Power

Intent: To encourage the development and use of grid-source, renewable energy technologies on a net zero pollution basis.

Materials & Resources (MR)

MRP1 – Storage & Collection of Recyclables

Intent: To facilitate the reduction of waste generated by building occupants that is hauled to and disposed of in landfills.

MR1 – Building Reuse

MR1.1–Maintain 75% of Existing Walls, Floors & Roof

Intent: To extend the lifecycle of existing building stock, conserve resources, retain cultural resources, reduce waste and reduce environmental impacts of new buildings as they relate to materials manufacturing and transport.

MR1.2 - Maintain 50% of Interior Walls, Ceilings & Doors

Intent: To extend the lifecycle of existing building stock, conserve resources, retain cultural resources, reduce waste and reduce environmental impacts of new buildings as they relate to materials manufacturing and transport.

MR2 - Construction Waste Management

MR2 - Divert 50% or 75% from Disposal

Intent: To divert construction and demolition debris from disposal in landfills and incineration facilities. Redirect recyclable recovered resources back to the manufacturing process and reusable materials to appropriate sites.

MR3 – Materials Reuse, 5%

Intent: To reuse building materials and products to reduce demand for virgin materials and reduce waste, thereby lessening impacts associated with the extraction and processing of virgin resources.

MR4 - Recycled Content, 5% - 10% (post-consumer + ½ pre-consumer)

Intent: To increase demand for building products that incorporate recycled content materials, thereby reducing impacts resulting from extraction and processing of virgin materials.

MR5 - Regional Materials, 10% - 20% Extracted, Processed & Manufactured Regionally

Intent: To increase demand for building materials and products that are extracted and manufactured within the region, thereby supporting the use of indigenous resources and reducing the environmental impacts from transportation.

Division 4: Special Planning Issues

MR6 - Rapidly Renewable Materials

Intent: To reduce the use and depletion of finite raw materials and long-cycle materials by replacing them with rapidly renewable materials.

MR7 - Certified Wood

Intent: To encourage environmentally responsible forest management.

Indoor Environmental Quality (IEQ)

IEQP1 - Minimum IAQ Performance

Intent: To establish minimum indoor air quality (IAQ) performance to enhance indoor air quality in buildings, thus contributing to the comfort and well-being of the occupants.

IEQP2 - Environmental Tobacco Smoke (ETS) Control

Intent: To prevent or minimize exposure of building occupants, indoor surfaces and ventilation air distribution systems to environmental tobacco smoke (ETS).

IEQ1 - Outdoor Air Delivery Monitoring

Intent: To provide capacity for ventilation system monitoring to help promote occupant comfort and well-being.

IEQ2 - Increased Ventilation

Intent: To provide additional outdoor air ventilation to improve indoor air quality (IAQ) and promote occupant comfort.

IEQ3 - Construction IAQ Management Plan

IEQ3.1 - During Construction

Intent: To reduce indoor air quality (IAQ) problems resulting from construction or renovation and promote the comfort and well-being of construction workers and building occupants.

IEQ3.2 - Before Occupancy

Intent: To reduce indoor air quality (IAQ) problems resulting from construction or renovation and promote the comfort and well-being of construction workers and building occupants.

IEQ4 - Low-Emitting Materials

IEQ4.1 - Adhesives & Sealants

Intent: To reduce the quality of indoor air contaminants that are odorous, irritating and/or harmful to the comfort and well-being of installers and occupants.

IEQ4.2 - Paints & Coatings

Intent: To reduce the quality of indoor air contaminants that are odorous, irritating and/or harmful to the comfort and well-being of installers and occupants.

IEQ4.3 - Flooring Systems

Intent: To reduce the quality of indoor air contaminants that are odorous, irritating and/or harmful to the comfort and well-being of installers and occupants.

IEQ4.4 - Composite Wood & Agrifiber Products

Intent: To reduce the quality of indoor air contaminants that are odorous, irritating and/or harmful to the comfort and well-being of installers and occupants.

IEQ5 - Indoor Chemical & Pollutant Source Control

Intent: To minimize the exposure of building occupants to potentially hazardous particulates and chemical pollutants.

IEQ6 – Controllability of Systems

IEQ6.1 –Lighting

Intent: To provide a high level of lighting system control by individual occupants or groups in multi-occupant spaces (e.g., classrooms and conference areas) and promote their productivity, comfort, and well-being.

IEQ6.2 –Thermal Control

Intent: To provide a high level of thermal comfort system control by individual occupants or groups in multi-occupant spaces (e.g., classrooms and conference areas) and promote their productivity, comfort, and well-being

Division 4: Special Planning Issues

IEQ7 – Thermal Comfort

IEQ7.1 – Thermal Comfort, Design

Intent: To provide a comfortable thermal environment that promotes occupant productivity and well-being.

IEQ7.2 – Thermal Comfort, Verification

Intent: To provide for the assessment of building occupant and thermal comfort over time.

IEQ8 – Daylight and Views

IEQ8.1 – Daylight 75% of Spaces

Intent: To provide building occupants with a connection between indoor spaces and the outdoors through the introduction of daylight and views into the regularly occupied areas of the building.

IEQ8.2 – Views for 90% of Spaces

Intent: To provide building occupants with a connection between indoor spaces and the outdoors through the introduction of daylight and views into the regularly occupied areas of the building.

LEED 2009 for New Construction and Major Renovations		Project Checklist		Project Name	
				Date	
18	4	4	Sustainable Sites	Possible Points: 26	
Y	?	N		Y	?
Y			Prereq 1 Construction Activity Pollution Prevention		
1			Credit 1 Site Selection	1	
5			Credit 2 Development Density and Community Connectivity	5	
1			Credit 3 Brownfield Redevelopment	1	
6			Credit 4.1 Alternative Transportation—Public Transportation Access	6	
1			Credit 4.2 Alternative Transportation—Bicycle Storage and Changing Rooms	1	
3			Credit 4.3 Alternative Transportation—Low-Emitting and Fuel-Efficient Vehicles	3	
2			Credit 4.4 Alternative Transportation—Parking Capacity	2	
1			Credit 5.1 Site Development—Protect or Restore Habitat	1	
1			Credit 5.2 Site Development—Maximize Open Space	1	
1			Credit 6.1 Stormwater Design—Quantity Control	1	
1			Credit 6.2 Stormwater Design—Quality Control	1	
1			Credit 7.1 Heat Island Effect—Non-roof	1	
1			Credit 7.2 Heat Island Effect—Roof	1	
1			Credit 8 Light Pollution Reduction	1	
5	2	3	Water Efficiency	Possible Points: 10	
Y			Prereq 1 Water Use Reduction—20% Reduction		
4			Credit 1 Water Efficient Landscaping	2 to 4	
2			Credit 2 Innovative Wastewater Technologies	2	
1	2	1	Credit 3 Water Use Reduction	2 to 4	
7	14	14	Energy and Atmosphere	Possible Points: 35	
Y			Prereq 1 Fundamental Commissioning of Building Energy Systems		
Y			Prereq 2 Minimum Energy Performance		
Y			Prereq 3 Fundamental Refrigerant Management		
5	5	9	Credit 1 Optimize Energy Performance	1 to 19	
2	5		Credit 2 On-Site Renewable Energy	1 to 7	
2			Credit 3 Enhanced Commissioning	2	
2			Credit 4 Enhanced Refrigerant Management	2	
3			Credit 5 Measurement and Verification	3	
2			Credit 6 Green Power	2	
3	5	4	Materials and Resources	Possible Points: 14	
Y			Prereq 1 Storage and Collection of Recyclables		
1			Credit 1.1 Building Reuse—Maintain Existing Walls, Floors, and Roof	1 to 3	
1			Credit 1.2 Building Reuse—Maintain 50% of Interior Non-Structural Elements	1	
1	1		Credit 2 Construction Waste Management	1 to 2	
2			Credit 3 Materials Reuse	1 to 2	
6	6	3	Indoor Environmental Quality	Possible Points: 15	
Y			Prereq 1 Minimum Indoor Air Quality Performance		
Y			Prereq 2 Environmental Tobacco Smoke (ETS) Control		
1			Credit 1 Outdoor Air Delivery Monitoring	1	
1			Credit 2 Increased Ventilation	1	
1			Credit 3.1 Construction IAQ Management Plan—During Construction	1	
1			Credit 3.2 Construction IAQ Management Plan—Before Occupancy	1	
1			Credit 4.1 Low-Emitting Materials—Adhesives and Sealants	1	
1			Credit 4.2 Low-Emitting Materials—Paints and Coatings	1	
1			Credit 4.3 Low-Emitting Materials—Flooring Systems	1	
1			Credit 4.4 Low-Emitting Materials—Composite Wood and Agrifiber Products	1	
1			Credit 5 Indoor Chemical and Pollutant Source Control	1	
1			Credit 6.1 Controllability of Systems—Lighting	1	
1			Credit 6.2 Controllability of Systems—Thermal Comfort	1	
1			Credit 7.1 Thermal Comfort—Design	1	
1			Credit 7.2 Thermal Comfort—Verification	1	
1			Credit 8.1 Daylight and Views—Daylight	1	
1			Credit 8.2 Daylight and Views—Views	1	
4	2		Innovation and Design Process	Possible Points: 6	
1			Credit 1.1 Innovation in Design: Specific Title	1	
1			Credit 1.2 Innovation in Design: Specific Title	1	
1			Credit 1.3 Innovation in Design: Specific Title	1	
1			Credit 1.4 Innovation in Design: Specific Title	1	
1			Credit 1.5 Innovation in Design: Specific Title	1	
1			Credit 2 LEED Accredited Professional	1	
3	1		Regional Priority Credits	Possible Points: 4	
1			Credit 1.1 Regional Priority: Specific Credit	1	
1			Credit 1.2 Regional Priority: Specific Credit	1	
1			Credit 1.3 Regional Priority: Specific Credit	1	
1			Credit 1.4 Regional Priority: Specific Credit	1	
46	34	28	Total	Possible Points: 110	
<small>Certified 40 to 49 points Silver 50 to 59 points Gold 60 to 79 points Platinum 80 to 110</small>					

Division 4: Special Planning Issues

4.5 Commissioning

Commissioning practices are to be implemented into all procedures and documentation used in the planning, design, construction, closeout, and operations of this building. Provide for verification through the commissioning process that building systems are designed, installed, and perform according to DSF's project requirements, basis of design, and construction documents.

Implement the fundamental best practice commissioning procedures as outlined in the DSF AE and Consultant Policy and Procedure Manual. Provide a final commissioning report, signed by the commissioning provider, confirming that the fundamental commissioning requirements have been successfully executed. Specific commissioning submittal and documentation requirements are to be identified in the commissioning provider's contract and in the project bid documents. Engage a commissioning authority and adopt a commissioning plan. Task the commissioning provider to produce a final commissioning report once all outstanding commissioning activities are completed and all identified issues are resolved successfully. This project will require a third-party independent commissioning agent.

4.6 Hazardous Substances

The presence and location of hazardous materials is inventoried in the State's database titled Wisconsin Asbestos and Lead Management System (WALMS). In general, asbestos-containing materials that will require abatement prior to demolition within existing Cowley Hall will include floor tile and mastic, thermal system insulation (piping and tanks), and transite labtops.

The Division of State Facilities will contract directly with an asbestos abatement designer to produce abatement drawings and technical sections to be included in the bid documents. A/E will coordinate design with the asbestos abatement designer and provide the asbestos abatement designer CAD floor plans for use in developing abatement drawings.

4.7 Equipment

4.7.1 Movable and Fixed Equipment

- Office furnishings shall be provided by the University and funded through the GPR budget.
- Classroom furnishings shall be provided by the University and funded through the GPR budget.
- Communications equipment shall be provided by the University and funded through the GPR budget.
- One wall-mounted clock/transmitter (wireless master-clock system) facing the podium shall be provided for each classroom and teaching laboratory.
- Teaching podiums shall be provided in each classroom and teaching laboratory.
- Marker boards shall be provided in all classrooms and teaching laboratories. Marker boards should include a tack strip at the top edge. Refer to Division of State Facilities Accessibility Guidelines for height requirements.
- A pencil sharpener shall be provided in each classroom and teaching laboratory.
- Refuse containers shall be provided in all offices, classrooms, workrooms, corridors, lobbies, resource areas, etc.
- The lobby shall be provided with a signage directory and an area for donor recognition plaques.

4.7.2 Audio/Visual Equipment

The following equipment shall be considered for each classroom with final determination being made during design:

- Recessed ceiling mounted electric screen(s)
- Ceiling mounted projector(s)
- HD Document camera
- Interactive Pen Display (Annotation tablet)
- Wall mounted pan/tilt/zoom camera
- HDMI/DVI/Display Port switchers
- Touchpanel control system
- Wall mounted program speakers
- Ceiling mounted voice speakers
- Assistive listening system (ALS)
- Wireless presenter microphone
- Blu-ray DVD
- Workstation computer
- Audio DSP

The following equipment shall be considered for each conference room with final determination being made during design:

- Wall mounted flat panel or recessed ceiling mounted screen and ceiling mounted projector
- Ceiling mounted speakers
- Basic wall mounted control panel
- Wall connection plate for Laptops and auxiliary sources

The following equipment shall be considered for digital signage with final determination being made during design:

- (12) Flat panel displays located throughout building.
- Central equipment rack that houses players and servers.
- Up to 3 discrete channels of signage.

The following equipment shall be considered for each enclosed group study with final determination being made during design:

- Wall mounted flat panel display with speakers
- Wall plate connection plate for laptops and other sources
- Basic wall mounted control panel

Division 4: Special Planning Issues

This page intentionally left blank

5.1 Overview

The DSF project manager, UW System representatives, UW–La Crosse Cowley Hall Planning Committee, and the design team engaged in a collaborative “design-present-critique-refine-decide” process to reach consensus on “a” viable design direction for the proposed Cowley Hall Science Facility. The charge was to set the appropriate direction for the design to further evolve in the future design development sequence.

The scope of services outlined by DSF in the A/E contract for the Pre-Design Study include the following:

- Functional analysis of building program components, including alternative functional concepts, and recommendation of the option that best meets the needs of this project. This analysis should include floor plan diagrams of functional components and massing diagrams.
- Analysis of phasing options if phasing is necessary because of site and/or budget constraints.
- Analysis of utilities necessary to serve this project.
- Analysis of sustainability options necessary to obtain LEED-NC™ Silver certification.

5.2 Approach

The development of the design response for the Cowley Hall Science Building was impacted by four key components:

- **NEED** - The Building Program describes the spatial regiment for a 200,945 ASF/327,522 GSF facility to address the instructional and research needs for the physical and life sciences at UW-La Crosse.
- **OPERATION** - The existing 180,000 GSF facility must stay in use while the new building is being constructed. There is no surge space on campus to temporarily house the technical and spatial requirements of a science teaching and research institution.
- **SITE** - The targeted site is a parking lot north of the present building and is bound on all sides by campus Master Plan directives.
- **COST** - The cost to provide a new 200,945 ASF/327,522 GSF state-of-the-art science facility as a single project in one biennium budget is unrealistic. The project will need to be phased to distribute its costs over successive bienniums.

These components need to be analyzed together to reach a viable conceptual plan for the development of this project. The study team accepted the premise of the need for a phased implementation approach for the successful delivery of this project. This decision automatically triggered the need for a way to connect the first phase to the existing building for some period of time until the entire project is fully implemented. The next issue to resolve was to assess the overall program requirements to determine the priority functional needs for Phase 1. The unanimous choice was to focus on the teaching, open, and research laboratory areas.

5.3 Phased Building Program

The most pressing need for a high quality science curriculum is the laboratory environment. The decision to focus on the teaching, open, and research laboratory areas in Phase 1 equates to 107,880 ASF, or approximately 179,800 GSF. Phase 2 would provide the balance of the program needs, including the classrooms, faculty offices, and other ancillary departmental spaces. The Phase 2 work equates to 93,065 ASF, or approximately 147,722 GSF.

Division 5: Pre-Design Concept

The following table summarizes the breakdown of the Building Program and assigns each space to a phase.

UNIT NO.	UNIT	ASF / SPACE	NO. OF SPACES	TOTAL ASF	PHASE I ASF	PHASE II ASF
1	Classrooms					
1A	24 Seat Classroom	600	2	1,200	0	1,200
1B	32 Seat Classroom	800	3	2,400	0	2,400
1C	40 Seat Classroom	1,000	1	1,000	0	1,000
1D	48 Seat Classroom	1,200	3	3,600	0	3,600
1E	120 Seat Classroom	2,880	2	5,760	0	5,760
1F	150 Seat Classroom	3,600	2	7,200	0	7,200
1G	Classroom Support – Lecture Prep Storage	320	2	640	0	640
				21,800	0	21,800
2	Miscellaneous Instructional/Support Spaces					
2A	Science Education Methods Laboratory					
2A1	Lab Area	1,800	1	1,800	0	1,800
2A2	Prep Area and Stor. (Share with Math Ed Labs)	320	1	320	0	320
2B	Building Laboratory Support				0	0
2B1	Dark Room	160	1	160	160	0
2B2	Dry Chemical Storage	800	1	800	800	0
2B3	Acid Storage	160	1	160	160	0
2C	Student Collaborative Learning Spaces	3,364	1	3,364	0	3,364
2D	Testing Room(s)	120	4	480	0	480
2E	Office Suite Circulation	2,727	1	2,727	0	2,727
2F	Conference Room	600	4	2,400	0	2,400
2G	Shared Printing Areas	80	4	320	0	320
2H	Chemical Waste Holding	160	1	160	0	160
2I	Field Equipment Storage	1,280	1	1,280	0	1,280
2J	Shop	1,280	1	1,280	0	1,280
2K	Faculty Resource Center	640	2	1,280	0	1,280
2L	Vending & Seating Area	450	3	1,350	0	1,350
2M	Cyber Café			1,000	0	1,000
	<i>Vending/Food Cart</i>	<i>100</i>	<i>1</i>	<i>0</i>	<i>0</i>	<i>0</i>
	<i>Seating</i>	<i>900</i>	<i>1</i>	<i>0</i>	<i>0</i>	<i>0</i>
				18,881	1,120	17,761

Division 5: Pre-Design Concept

UNIT NO.	UNIT	ASF / SPACE	NO. OF SPACES	TOTAL ASF	PHASE I ASF	PHASE II ASF
3	Biology					
3A	Department Chair's Office	120	1	120	0	120
3B	Ranked Faculty Office	120	22	2,640	0	2,640
3C	Future Ranked Faculty Office	120	7	840	0	840
3D	Lecturer – Full Time	120	5	600	0	600
3E	Lecturer – Part Time	120	1	120	0	120
3F	Support Staff/Reception Area/Files			458	0	458
3G	Secure Office Storage (4 storage cabinets)	120	1	120	0	120
3H	Workroom	120	2	240	0	240
3I	Teaching Assistants	120	8	960	0	960
3J	Graduate Students	120	17	2,040		2,040
3K	Lab Support Staff	120	3	360	0	360
3L	Introductory Biology Laboratory	1,280	3	3,840	3,840	0
3M	Anatomy/Physiology Laboratory (includes ESS)	1,280	3	3,840	3,840	0
3N	Aquatics Laboratory	1,280	1	1,280	1,280	0
3O	Animal/Organizimal Laboratory	1,280	1	1,280	1,280	0
3P	Botany Laboratory (adjacent to Greenhouse)	1,280	1	1,280	0	1,280
3Q	Cell Laboratory	1,280	1	1,280	1,280	0
3R	Genetics Laboratory	1,280	1	1,280	1,280	0
3S	Laboratory Support			0	0	0
3S1	Anatomy/Physiology Prep. & Cadaver Storage	1,280	1	1,280	1,280	0
3S2	Introductory Biology/Aquatics Prep/Storage	320	2	640	640	0
3S3	Animal/Organizimal & Botany Prep/Storage	640	1	640	640	0
3S4	Cell Genetics Preparation/Autoclave	960	1	960	960	0
3S5	Core Microscope Suite	960	1	960	960	0
3S6	PCR Suite – shared with Microbiology	320	1	320	320	0
3S7	Cold Room	320	1	320	320	0
3T	Biology Special Projects Laboratory	480	1	480	0	480
3U	Faculty/Student Research (large paired lab)	1,440	7	10,080	10,080	0
3V	Faculty/Student Research (paired lab)	640	3	1,920	1,920	0
3W	Environmental Sample Processing Room	1,280	1	1,280	1,280	0
3X	Environmental Chamber Room	400	1	400	400	0
3Y	Vivarium			0	0	0
3Y1	Animal Rooms	120	8	960	0	960
3Y2	Procedures Room	480	2	960	0	960
3Y3	Cage Wash	320	1	320	0	320
3Y4	Storage	160	2	320	0	320
3Y5	Dirty Room	160	1	160	0	160
3Y6	Lab Manager	120	1	120	0	120
3Z	Herbarium	960	1	960	0	960
3AA	Greenhouse			0	0	0
3AA1	Greenhouse	960	1	960	0	960
3AA2	Headhouse	160	1	160	0	160
3AA3	Aquatics Space	160	1	160	0	160
3AA4	Isolation Space	320	2	640	0	640
3AB	Specimen Museum			0	0	0
3AB1	Display Specimen	640	1	640	0	640
3AB2	Specimen Non-Display	320	2	640	0	640
3AB3	Office Area	60	1	60	0	60
3AB4	Rock Collection	160	1	160	0	160
3AB5	Table and Chairs	750	1	750	0	750
3AC	General Lab/Departmental Storage	120	3	360	360	0
				50,188	31,960	18,228

Division 5: Pre-Design Concept

UNIT NO.	UNIT	ASF / SPACE	NO. OF SPACES	TOTAL ASF	PHASE I ASF	PHASE II ASF
4	Chemistry					
4A	Department Chair's Office	120	1	120	0	120
4B	Ranked Faculty Office	120	16	1,920	0	1,920
4C	Future Ranked Faculty Office	120	1	120	0	120
4D	Lecturer – Full Time	120	9	1,080	0	1,080
4E	Lecturer – Part Time	60	2	120	0	120
4F	Support Staff/Reception Area/Files			446	0	446
	<i>Academic Department Associate</i>	80	1	0	0	0
	<i>Future Support Staff</i>	80	1	0	0	0
	<i>Student Workers</i>	35	2	0	0	0
	<i>Reception Area</i>	150	1	0	0	0
	<i>Lateral Files</i>	66	1	0	0	0
4G	Workroom	120	1	120	0	120
4H	Secure Storage (1 storage; 3 file cabinets)	120	1	120	0	120
4I	Lab Support Staff	120	2	240	0	240
4J	Student Workers	210	1	210	0	210
4K	General Chemistry I Laboratory	1,280	3	3,840	3,840	0
4L	General Chemistry II Laboratory	1,280	2	2,560	2,560	0
4M	Biochemistry Laboratory	1,280	2	2,560	2,560	0
4N	Survey of Organic Chemistry Laboratory	1,280	1	1,280	1,280	0
4O	Organic Chemistry Majors Laboratory	1,280	2	2,560	2,560	0
4P	Analytical Chemistry Laboratory	1,280	2	2,560	1,280	1,280
4Q	Instrumental Chemistry Laboratory	1,280	1	1,280	1,280	0
4R	Physical Chemistry Laboratory	1,280	1	1,280	1,280	0
4S	Laboratory Support			0	0	0
4S1	General Chemistry Prep/Balance	640	1	640	640	0
4S2	General/Survey of Organic Prep/Balance	640	1	640	640	0
4S3	General Chemistry II Prep/Balance	640	1	640	640	0
4S4	Biochemistry Prep/Equipment	640	1	640	640	0
4S5	Organic Chemistry Majors Prep/Equipment	640	1	640	640	0
4S6	Analytical Chemistry Prep/Balance	640	1	640	640	0
4S7	Instrumental /Physical Chemistry Prep/Balance	640	1	640	640	0
4S8	NMR (should be in basement)	480	1	480	480	0
4S9	Stock Dispensing	960	1	960	960	0
4S10	Flammable Storage	320	1	320	320	0
4T	Chemical Analysis Computer Lab	840	1	840	0	840
4U	Computerized Instrument. Lab (computational)	480	1	480	0	480
4V	Faculty/Student Research (standard)			0	0	0
4V1	Faculty/Student Research – Biochemistry	400	4	1,600	1,600	0
4V2	Faculty/Student Research – Synthesis	400	6	2,400	2,400	0
4V3	Faculty/Student Research – Analytical	400	3	1,200	1,200	0
4V4	Faculty/Student Research – Chemistry Education	400	1	400	400	0
4V5	Faculty/Student Research – Phys./Instrumental	400	2	800	800	0
4W	Faculty/Student Research (computational)	200	1	200	0	200
4X	General Lab/Departmental Storage	120	3	360	360	0
				36,936	29,640	7,296

Division 5: Pre-Design Concept

UNIT NO.	UNIT	ASF / SPACE	NO. OF SPACES	TOTAL ASF	PHASE I ASF	PHASE II ASF
5	Geography & Earth Science					
5A	Department Chair's Office	120	1	120	0	120
5B	Ranked Faculty Office	120	7	840	0	840
5C	Future Ranked Faculty Office	120	2	240	0	240
5D	Lab Support Staff	120	1	120	0	120
5E	Support Staff/Reception Area/Files			248	0	248
5F	Office Storage	120	1	120	0	120
5G	Workroom	120	1	120	0	120
5H	Earth Science Laboratory	1,280	1	1,280	1,280	0
5I	Geomorphology & Weather Laboratory	1,280	1	1,280	1,280	0
5J	Introductory GIS Laboratory	1,280	1	1,280	0	1,280
5K	Advanced GIS Laboratory			0	0	0
5K1	Main Laboratory	1,600	1	1,600	0	1,600
5K2	Server Room	160	1	160	0	160
5L	Laboratory Support			0	0	0
5L1	Earth Science Prep Storage	320	1	320	320	0
5L2	Geomorphology Prep Storage	320	1	320	320	0
5L3	Geography Storage	480	1	480	480	0
5L4	Cold Room	160	1	160	160	0
5M	Faculty/Student Research (standard)	400	5	2,000	2,000	0
5N	Faculty/Student Research (computational)	160	4	640	0	640
5O	General Lab/Departmental Storage	120	3	360	360	0
				11,688	6,200	5,488
6	Mathematics					
6A	Department Chair's Office	120	1	120	0	120
6B	Ranked Faculty Office	120	24	2,880	0	2,880
6C	Future Ranked Faculty Office	120	3	360	0	360
6D	Lecturer – Full Time	120	5	600	0	600
6E	Lecturer – Part Time	60	2	120	0	120
6F	Lab Support Staff	120	1	120	0	120
6G	Support Staff/Reception Area/Files			428	0	428
6H	Graduate Students	120	1	120	0	120
6I	Workroom	120	1	120	0	120
6J	Office Storage	120	1	120	0	120
6K	Laboratory – Math Education Space	1,600	2	3,200	0	3,200
6L	Math Research Team Rooms/Collaboratorium	240	3	720	0	720
6M	Undergraduate Research/Library			1,095	0	1,095
6N	General Lab/Departmental Storage	120	1	120	0	120
				10,123	0	10,123

Division 5: Pre-Design Concept

UNIT NO.	UNIT	ASF / SPACE	NO. OF SPACES	TOTAL ASF	PHASE I ASF	PHASE II ASF
7	Microbiology					
7A	Department Chair's Office	120	1	120	0	120
7B	Ranked Faculty Office	120	6	720	0	720
7C	Future Ranked Faculty Office	120	1	120	0	120
7D	Lecturer – Full Time	120	5	600	0	600
7E	Support Staff/Reception Area/Files			283	0	283
7F	Graduate Assistants/Students	120	9	1,080	0	1,080
7G	Office Storage	120	1	120	0	120
7H	Lab Support Staff	120	3	360	0	360
7I	Fundamental Microbiology Laboratory	1,280	1	1,280	1,280	0
7J	Pathogenic Bacteriology/Medical Mycology Lab	1,280	1	1,280	1,280	0
7K	Bacterial Physiology/Genetics/Microbial Ecology	1,280	1	1,280	1,280	0
7L	Gen Ed/Food Microbiology/Nutrition Laboratory	1,280	1	1,280	1,280	0
7M	Immunology/Virology Laboratory	1,280	1	1,280	1,280	0
7N	Laboratory Support			0	0	0
7N1	Gen Microbiology Prep/Autoclave	1,600	1	1,600	1,600	0
7N2	Tissue Culture	320	1	320	320	0
7N3	Centrifuge Room	480	1	480	480	0
7N4	Fermentation Lab	800	1	800	800	0
7N5	Cold Room	160	1	160	160	0
7N6	Equipment/Instrumentation Room and Storage	480	1	480	480	0
7O	Faculty/Student Research (large)			0	0	0
7O1	Faculty/Student Research - Virology	960	1	960	960	0
7O2	Faculty/Student Research – Pathogenic	960	1	960	960	0
7O3	Faculty/Student Research – Genetics	960	1	960	960	0
7P	Faculty/Student Research (medium)			0	0	0
7P1	Faculty/Student Research – Immunology	640	1	640	640	0
7P2	Faculty/Student Research – Bacterial Physiology	640	1	640	640	0
7P3	Faculty/Student Research – Microbial Ecology	640	1	640	640	0
7Q	Faculty/Student Research (standard)			0	0	0
7Q1	Faculty/Student Research – Microbiology	480	1	480	480	0
7Q2	Faculty/Student Research – Food Microbiology	480	1	480	480	0
7R	General Lab/Departmental Storage	120	3	360	360	0
				19,763	16,360	3,403

Division 5: Pre-Design Concept

UNIT NO.	UNIT	ASF / SPACE	NO. OF SPACES	TOTAL ASF	PHASE I ASF	PHASE II ASF
8	Physics					
8A	Department Chair's Office	120	1	120	0	120
8B	Ranked Faculty Office	120	7	840	0	840
8C	Future Ranked Faculty Office	120	1	120	0	120
8D	Lecturer – Part Time	120	1	120	0	120
8E	Support Staff/Reception Area/Files			237	0	237
8F	Workroom	120	1	120	0	120
8G	Office Storage	120	1	120	0	120
8H	Lab Support Staff	120	1	120	0	120
8I	Student Workers (Lab Prep)	35	3	105	0	105
8J	Introductory Physics Laboratory	1,920	1	1,920	1,920	0
8K	Electronics/Astronomy Laboratory	1,280	1	1,280	1,280	0
8L	Studio Lab	1,280	1	1,280	1,280	0
8M	Laboratory Support			0	0	0
8M1	Introductory Prep & Storage	320	1	320	320	0
8M2	Electronics Prep & Storage	320	1	320	320	0
8M3	Studio Prep & Storage	640	1	640	640	0
8N	Holography Laboratory	320	1	320	320	0
8O	Optics Laboratory	960	1	960	960	0
8P	Advanced/Experimental Physics Laboratory	1,280	1	1,280	1,280	0
8Q	Laboratory Support			0	0	0
8Q1	Optics Prep & Storage	320	1	320	320	0
8Q2	Advanced Prep & Storage	320	1	320	320	0
8R	Computational Computer Lab	480	1	480	0	480
8S	Faculty/Student Research (x-large)	1,280	2	2,560	2,560	0
8T	Faculty/Student Research (Theorists)	960	1	960	0	960
8U	Faculty/Student Research (Experimentalists)	640	3	1,920	1,920	0
8V	Planetarium			0	0	0
8V1	Planetarium (two-story space)	1,050	1	1,050	0	1,050
8V2	Storage	120	2	240	0	240
8V3	Prefunction/Welcome Area	500	1	500	0	500
8V4	Display Cases	40	1	40	0	40
8W	Rooftop Observatory			0	0	0
8W1	Telescopes	360	1	360	0	360
8W2	Observation Platform	750	1	750	0	750
8W3	Waiting Area	300	1	300	0	300
8W4	Storage	120	1	120	0	120
8X	General Lab/Departmental Storage	120	2	240	240	0
8Y	Student Organization Space	120	2	240	0	240
				20,622	13,680	6,942

Division 5: Pre-Design Concept

UNIT NO.	UNIT	ASF / SPACE	NO. OF SPACES	TOTAL ASF	PHASE I ASF	PHASE II ASF
9	Radiation Center					
9A	Director/Safety Officer	120	1	120	120	0
9B	Sealed Source Laboratory	1,280	1	1,280	1,280	0
9C	Open Source Laboratory	1,280	1	1,280	1,280	0
9D	Laboratory Support – Stock Room	160	1	160	160	0
9E	Shared Isotope Prep	400	1	400	400	0
9F	Faculty/Student Research (Chemistry)	400	1	400	400	0
9G	Faculty/Student Research (Physics)	1,280	1	1,280	1,280	0
9H	Laboratory Support			0	0	0
9H1	Special Instruments	267	1	267	267	0
9H2	Nuclide Storage	160	1	160	160	0
9H3	Neutron Howitzer	53	1	53	53	0
				5,400	5,400	0
10	River Studies Center					
10A	Faculty/Student Research Wet Lab	1,440	1	1,440	1,440	0
10B	Class 100 Clean Research Lab	320	1	320	320	0
10C	Faculty Student Research	1,440	1	1,440	1,440	0
10D	Laboratory Support			0	0	0
10D1	Microscope – 11	160	1	160	160	0
10D2	Fish Culture – 42D	160	1	160	160	0
				3,520	3,520	0
11	College of Science and Health – Dean’s Office					
11A	Dean’s Office	185	1	185	0	185
11B	Associate Dean’s Office	160	1	145	0	145
11C	Assistant to Dean’s Office	140	1	135	0	135
11D	Dean’s Assistant	140	1	135	0	135
11E	Assistant to Dean	140	1	135	0	135
11F	Support Staff/Reception Area/Files			449	0	449
11G	Workroom	120	1	120	0	120
11H	Conference Room	360	1	360	0	360
11I	Storage	120	1	120	0	120
11J	Grad Assistant/Advisor	120	1	120	0	120
11K	Administrative Specialist	120	1	120	0	120
				2,024	0	2,024

Division 5: Pre-Design Concept

UNIT NO.	UNIT	ASF / SPACE	NO. OF SPACES	TOTAL ASF	PHASE I ASF	PHASE II ASF
12	Building Support					
12A	Arrival Space Primary	1,500	1	1,500	1,175	325
12B	Arrival Space Secondary	900	2	1,800	1,480	320
12C	Equipment Storage	500	1	500	375	125
12D	Supply Storage	400	1	400	400	0
12E	Custodial Maintenance Room	200	1	200	200	0
12F	Loading Dock	320	1	320	320	0
12G	Temporary Storage	640	1	640	640	0
12H	Building Recycling Collection Area	200	1	200	200	0
12I	Recycling Area (two per floor)	25	8	200	100	100
12J	IT & Electrical Closets	100	4	400	300	100
12K	Sustainability Support Space	0	0	0	0	0
12L	Custodial Closets	100	8	800	400	400
12M	IT Storage/Workroom	200	1	200	200	0
12N	Uni-Sex Restrooms	70	8	560	0	560
				7,720	5,790	1,930
1	Classrooms			21,800	0	21,800
2	Miscellaneous Instructional/Support Spaces			18,881	1,120	17,761
3	Biology			50,188	31,960	18,228
4	Chemistry			36,936	29,640	7,296
5	Geography & Earth Science			11,688	6,200	5,488
6	Mathematics			10,123	0	10,123
7	Microbiology			19,763	16,360	3,403
8	Physics			20,622	13,680	6,942
9	Radiation Center			5,400	5,400	0
10	River Studies Center			3,520	3,520	0
11	College of Science and Health – Dean’s Office			2,054	0	2,054
12	Building Support (Not included in Building ASF)			0	0	0
TOTAL ASF				200,975	107,880	93,095

Net to Gross Adjustment

Phase I – New Science Facility
 107,880 ASF 60% E.F. 179,800 GSF

Phase II – New or Renovated Departmental/Academic Facility
 93,065 ASF 63% E.F. 147,722 GSF

UW-La Crosse has identified program elements that are preferred to be included in Phase 1. The Design Team will be asked to monitor the project budget and incorporate these spaces into the design if the budget allows. These include the following:

- 4T Chemical Analysis Computer Lab – 840 sf
- 4U Computerized Instrument Lab – 480 sf
- 5J Introductory GIS Laboratory – 1,280 sf
- 5K Advanced GIS Laboratory – 1,760 sf
- 5N Faculty/Student Research – 640 sf
- 8R Computational Computer Lab – 480 sf
- 8T Faculty Student Research – 960 sf

5.4 Design Guidelines/Assumptions

5.4.1 Campus Architectural Guidelines

- Character: Buildings that possess similar characteristics perceived as a unified group
- Scale: Location, height (5 story max.), massing
- Form: No style, prefer design characteristics to reinforce an interpretive design direction
- Shape: Rectangular with respect to orthogonal grid.
Layer to establish pronounced base, middle, and top
- Walls: Natural: reddish brown brick
Openings: punched versus banded versus massed
Pattern: surface articulation and pronounced natural layering
Rhythm: discernable, repetitive pattern
- Roof: Flat versus sloped
Screen roof top projections
- Entrances: Distinctive and welcoming
Portal sets up interior “tone”
Protected
Signage
Barrier free accessible

5.4.2 Design Guidelines & Assumptions

- Formal entrances on Mall (West) with additional entrances on the west side.
- Position vertical circulation (stairs) at entry points.
- 4 level design scheme.
- Simplify wayfinding layout for interior halls.
- All of the classrooms on levels 1, 2, and 3.
- Private offices located at exterior walls for viewing and daylight.
- Develop modular laboratory environments for functional efficiency, accessibility, and future flexibility.
- Provide departmental presence on all floors.
- Design the structure to only support flexible room redistribution in the future, not for building expansion by addition.
- Incorporate DSF Sustainability Standards to minimize the use of non-renewable fuels and target LEED® Silver Certification.
 - Maximize natural (especially north and south) light into all habitable rooms and spaces with appropriate sun-control strategies.
 - Integrate comprehensive environmental strategies seamlessly into the facility for energy conservation.
- Provide flexible state-of-the-art classrooms with adaptable technology to support a variety of teaching and learning styles.
- Exterior design follows UW-L Campus Master Plan Architectural Guidelines.

5.5 Pre-Design Site Plan Concept

The project has two phases and two options for Phase 2.

Phase 1

New Addition

Phase 2

Option - New Addition

Option - Renovate existing 1963 center building and remove 1963 and 1968 office addition and 1968 east addition. Construct new addition to the east.

The site concepts herein reflect the above options accordingly.

To fully understand the Master Plan impact of the Cowley project, the design team felt it was important to include a slightly expanded perspective and include the current Central Campus Mall concept design. The intent is to understand how the site design for Cowley (Options 1 or 2) can be implemented in phases and ultimately be integrated into the future mall design. The Central Campus Mall is not presently within the scope of the Cowley Hall project. Options are explained as they relate to the Mall assuming full realization.

5.5.1 Central Campus Mall

Though not a current portion of the Cowley Hall project scope, the Central Campus Mall is an element that should influence the design direction of the Cowley site. As such, the pre-design team has attempted to look at the site planning, including building shape, location and massing, as it may relate to the future development of the Mall.

The current design philosophy of the Mall stems from the Campus Master Plan and consists of multiple layers. The foundation of the Mall is establishing open space and creating an iconic place on Campus to which students and faculty can relate and memorialize. The existing clock tower is a solid beginning and Campus would like to expand the focus. The design development of the new Academic Building began Mall concept development. The roots of which created the first layer by establishing dual walkways on each side of the space thereby establishing the central open space. The initial thought is the central space will consist of lawn with trees flanking outside the parallel walks. The next layer is honoring and developing the desire lines to accommodate expected circulation. Extracting the local vernacular of river systems the design team recognized their characteristic meandering and sinuous nature, their little pools and eddies, and fluid movement and patterns as a natural overlay in developing the desire lines. Using this foundation the Mall plan evolves by establishing patterns, anticipating building connections, walkway transitions and formalizing gathering nodes. The result creates an organic layer unifying and strengthening the Campus network as it reaches beyond the Mall proper.

Mall concepts shown in the planning for the new Academic Building and the Cowley Hall project are based on the above premise. Actual implementation of the Cowley project may need to honor existing conditions as did the Academic project, however it is important for the design development process to acknowledge future potential.

5.5.2 Pre-Design Concepts

The northeast building corner is a prominent location, highly visible to visitors entering campus via East Ave. and catering to student traffic from the northeast housing area. The corner concept should create a welcoming entry plaza addressing a minimum 270 degree perspective encompassing East Ave., the residence halls and the proposed Student Union Center. Design influences could be pulled from the Stadium plaza to help tie the campus network together across East Ave. The Badger St. corridor craves animation and life and the Cowley and Student Union Center projects will be the foundation to vitalizing this corridor. The site design for the Cowley project should be treated as an urban streetscape



Central Campus Mall - Concept

Division 5: Pre-Design Concept

providing active and passive spaces and create an interconnected atmosphere with the Student Union Center. The traffic generated by the new developments proximity to the academic core makes this a great place to incorporate bike parking for the project.

The northwest building corner will be a prominent link between Student Union Center and Mall. This corner should accentuate permeability of this link and take advantage of the high traffic by creating a social plaza. This will be a highly visible corner and will be a great place to see and be seen so it is anticipated to be a very active corner and entrance to the new Cowley addition.

The west building frontage should be designed to blend with existing conditions but also remain adaptable to a future Mall design.

The plazas and nodes created to serve the building entries will need to be designed with that in consideration. The west site area should be considered for rain gardens and infiltration opportunities given the soil profile and distance from the City Well Head Protection Zone. The west courtyard is an opportunity to give the building users a sense of place and ownership, an area they can call their own similar to the south courtyard of the new Academic building. Buildings like Cowley develop core users based on the focused departments and specialty programs. These users generally spend more time in fewer locales as they work through their education. The courtyard should be designed to embrace this opportunity of ownership and create a space unique to the building and a destination for the building occupants. The space should offer opportunities for reflection but should also reach out to the Mall so as not to over-seclude the space. Low site walls, pedestrian scale landscaping and small trees and rain gardens are some amenities to consider. In addition to or in lieu of rain gardens this is a prime area to explore alternate types of infiltration to aid in abating the stormwater generated by the expansive roof area.

The southwest building corner should be designed to address the academic core while fitting into the Mall concept. Site grades may create challenges in connecting directly to the clock tower plaza and actual configuration will vary pending the final building solution for the Phase 2 work (new south wing or renovated existing).

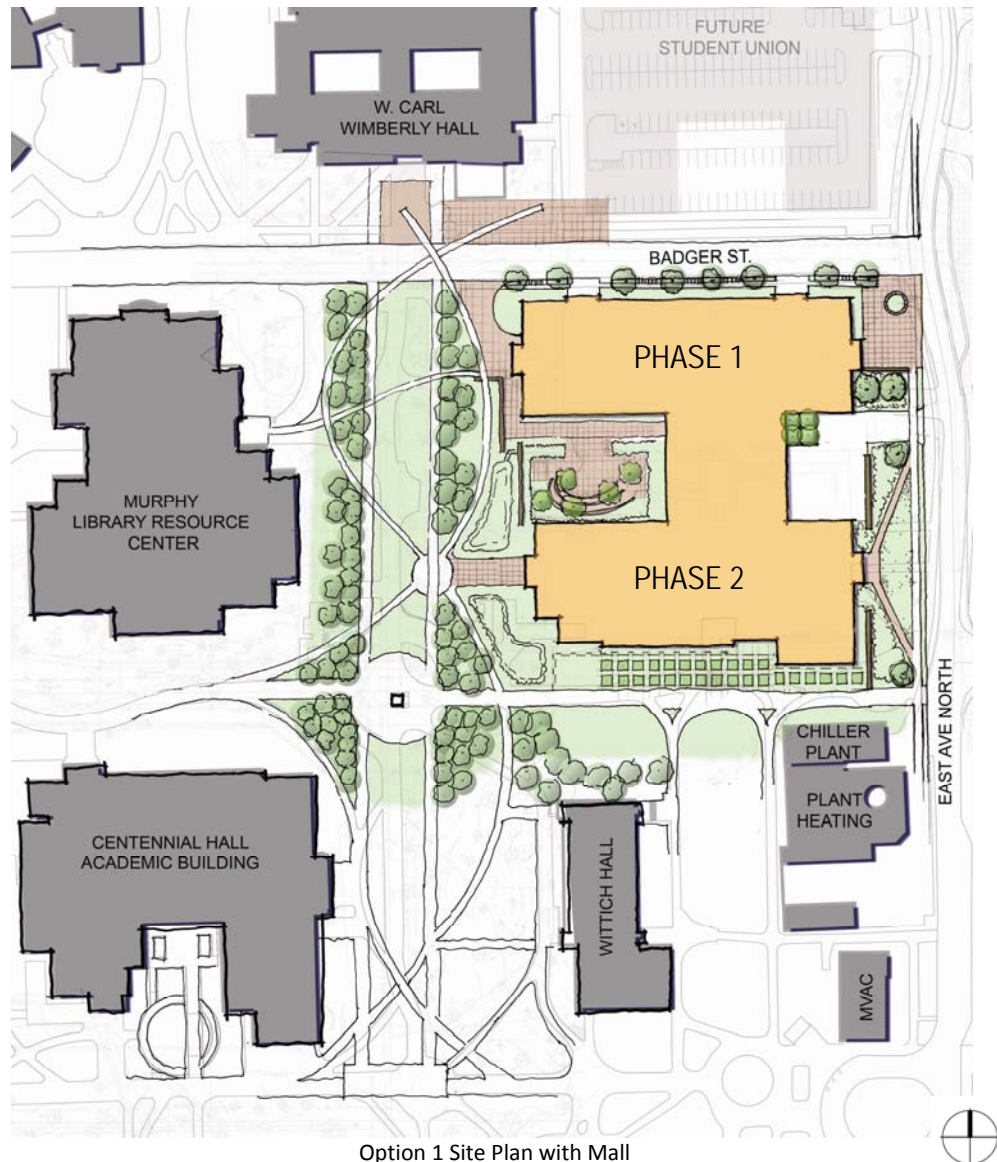

Option 1 Site Plan with Mall

Division 5: Pre-Design Concept

The south aspect of the building provides additional opportunities for incorporating rain gardens or water infiltration. These can be designed in an urban treatment with geometric design basis similar to the Academic Building south courtyard or more informal to replicate the character of the Academic Building's north and west rain gardens. The south building façade will have areas of windows but will also likely have large expanses of solid wall due to interior lecture halls. Landscape materials and screening should be explored to diminish scale issues in proximity to the pedestrian walkway. The south walk may be realigned to provide more direct circulation. Bicycle parking should also be incorporated near the southeast intersection of the sidewalk and East Ave. to encourage the pedestrian only zone within the academic core.

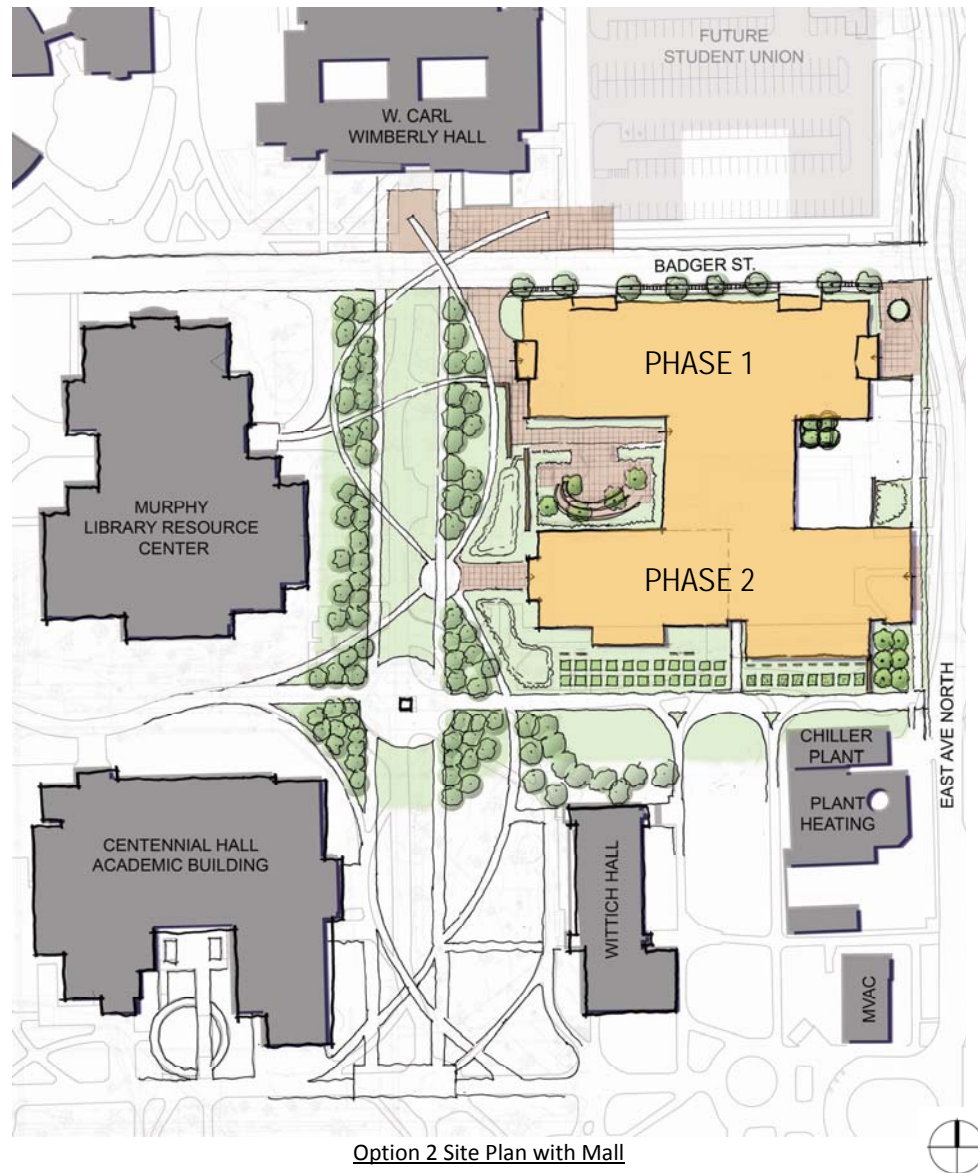

Option 2 Site Plan with Mall

The southeast building entry has the most variation within the building options. The new south building option solution establishes a desired buffer from East Ave. and also introduces opportunities for screening the east service courtyard. The entry itself should address traffic from the north and south and less so from directly east. The east courtyard will need to be predominately designed to accommodate the service, delivery and ADA parking needs as stated in the Transportation/Circulation section of this document. The renovation option pushes the south bar very far to the east. This solution creates a less desirable imposing frontage along East Ave. and minimizes opportunities for better incorporating the service functions and screening. This option will need to creatively soften the building presence on East Ave. and create an inviting entry to the academic core. Regardless of the option East Ave. is the prominent vehicular route and visitor route therefore screening of the service functions will be critical to establishing a desired street presence. The treatment of the east site should be unified and feel like one continuous design.

Division 5: Pre-Design Concept

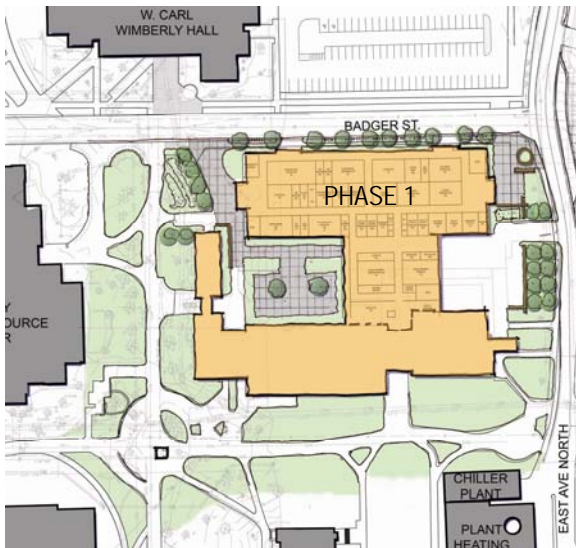

Phase 1 – New north building and connecting link to existing building.

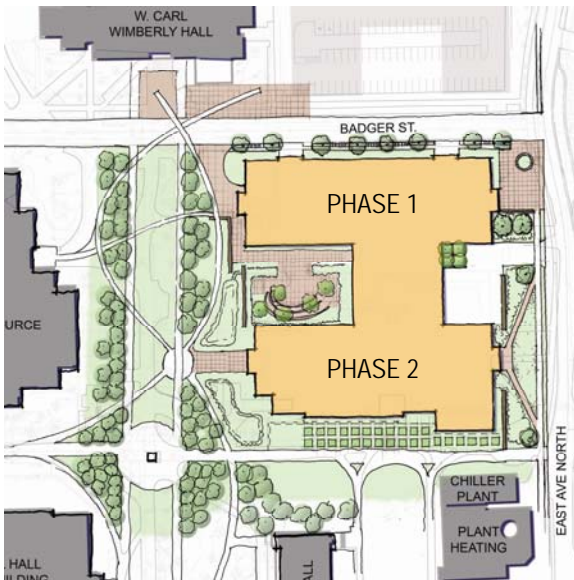

Option 1 – All new construction in Phase 2

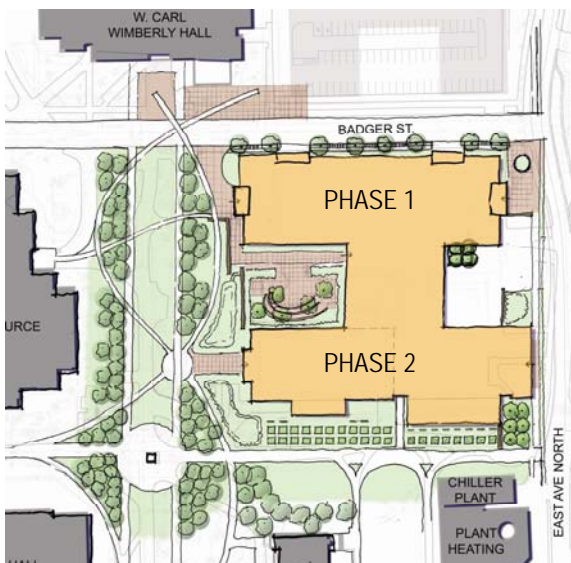

Option 2 – Renovate existing building with new addition at east in Phase 2

5.6 Building Massing and Functional Layout Diagrams

Numerous factors contributed to the development of a viable design option for this Pre-Design Study. The detailed space allocations in the Building Program established the individual room building blocks and their critical adjacencies. The distribution of the rooms in each department by phase helped to focus the prioritization and location preference for the conceptual floor plans. The decision to implement the project by phases and connect to the existing Cowley Hall until Phase 2 is underway has a significant impact on the plan circulation and location of departments. The campus context and Master Plan guidelines influenced the siting and configuration of the floor plans and building massing. The condition of the existing Cowley Hall facility and condition of the existing Cowley Hall facility and its core structural, mechanical, and electrical systems guide our recommendations to renovate or demolish in Phase 2. The building code requirements for a new addition, connected to a 1963-67 era existing building contributes to our use of the new facility in each phase of the work. Finally, the cost of the proposed construction work will add the final layer of data for the formulation of a viable design option for consideration.

The design options are presented by phase and depicted in annotated floor plans with a 3D massing diagram on the following pages.

- Phase 1 is a new 4 story (above grade), laboratory addition to the north of Cowley Hall. The building includes the teaching, open, and research labs for Biology, Chemistry, Geography/Earth Sciences, Microbiology, Physics, and the Radiation Center. The building connects directly to the center of the existing Cowley Hall on the first floor (grade) and via a new elevator and stair tower on floors 2, 3, and 4.
- Phase 2 has two options for consideration. A new addition that replaces the existing Cowley Hall building or a combination of a renovated 1963 center wing with a new addition to the east. The west office wing will remain in both options for interim office use until Phase 2 is ready for occupancy and will then be demolished. Both options will include the classrooms, collaborative learning spaces, departments, offices, conference rooms, and ancillary support spaces to complete the program needs.

Division 5: Pre-Design Concept

Phase 1 Concept Plan Development:

- Maximize northern daylight by locating teaching labs to the south side of a single-loaded corridor. Teaching labs will likely have an abundance of casework that would limit the amount of daylight into the space.
- Shared common wall provides a consistent path for routing vertical piping.
- Future Student Union and pedestrian mall to the north offer opportunities for a single-loaded corridor to share this pedestrian traffic.
- Teaching Lab Organization:
 - Physics Labs to be located on Level 1, Chemistry Labs to be located on Level 4, and the Radiation Center to be located in the basement.
- Concept diagrams illustrate the adjacencies requested by each department.
- Loading and storage areas located to the east to allow easy service access off of East Avenue.
- Vertical circulation located at the west, east, and south ends of plan. The southern stair and elevator will be used to connect differential floor heights between Phase 1 and the existing Cowley Hall.

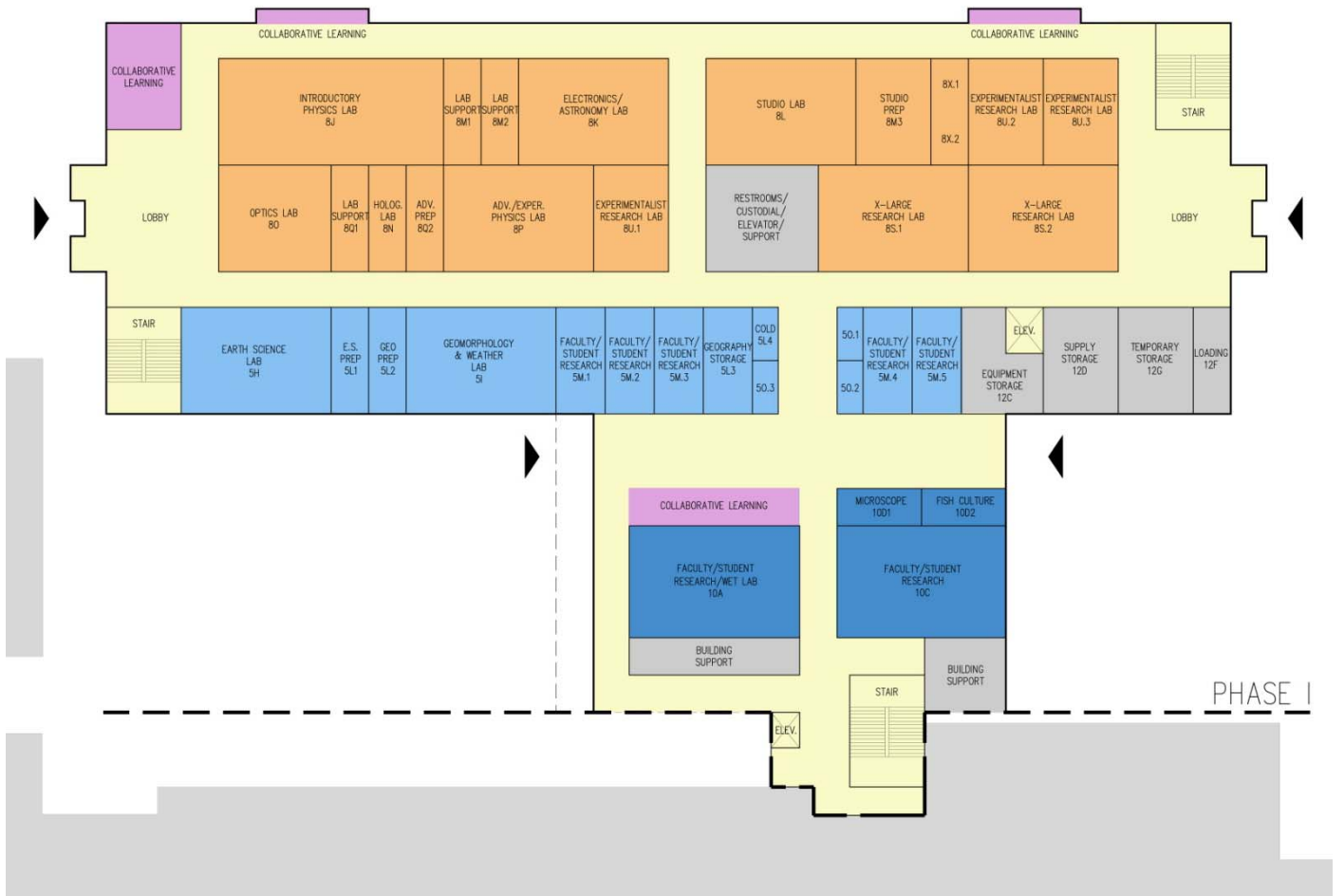
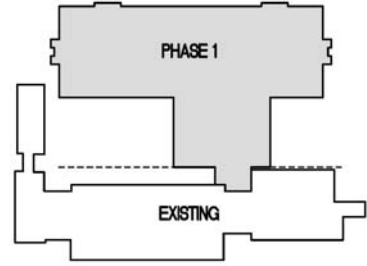

First Floor Plan/Phase 1

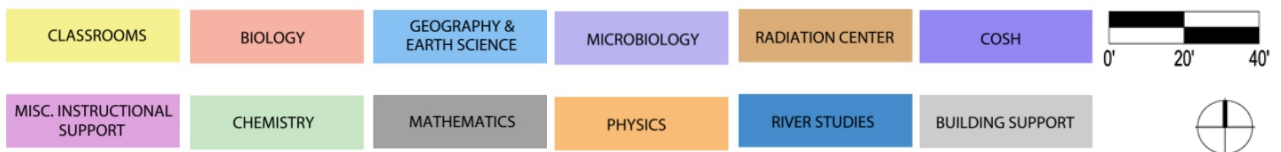

Division 5: Pre-Design Concept

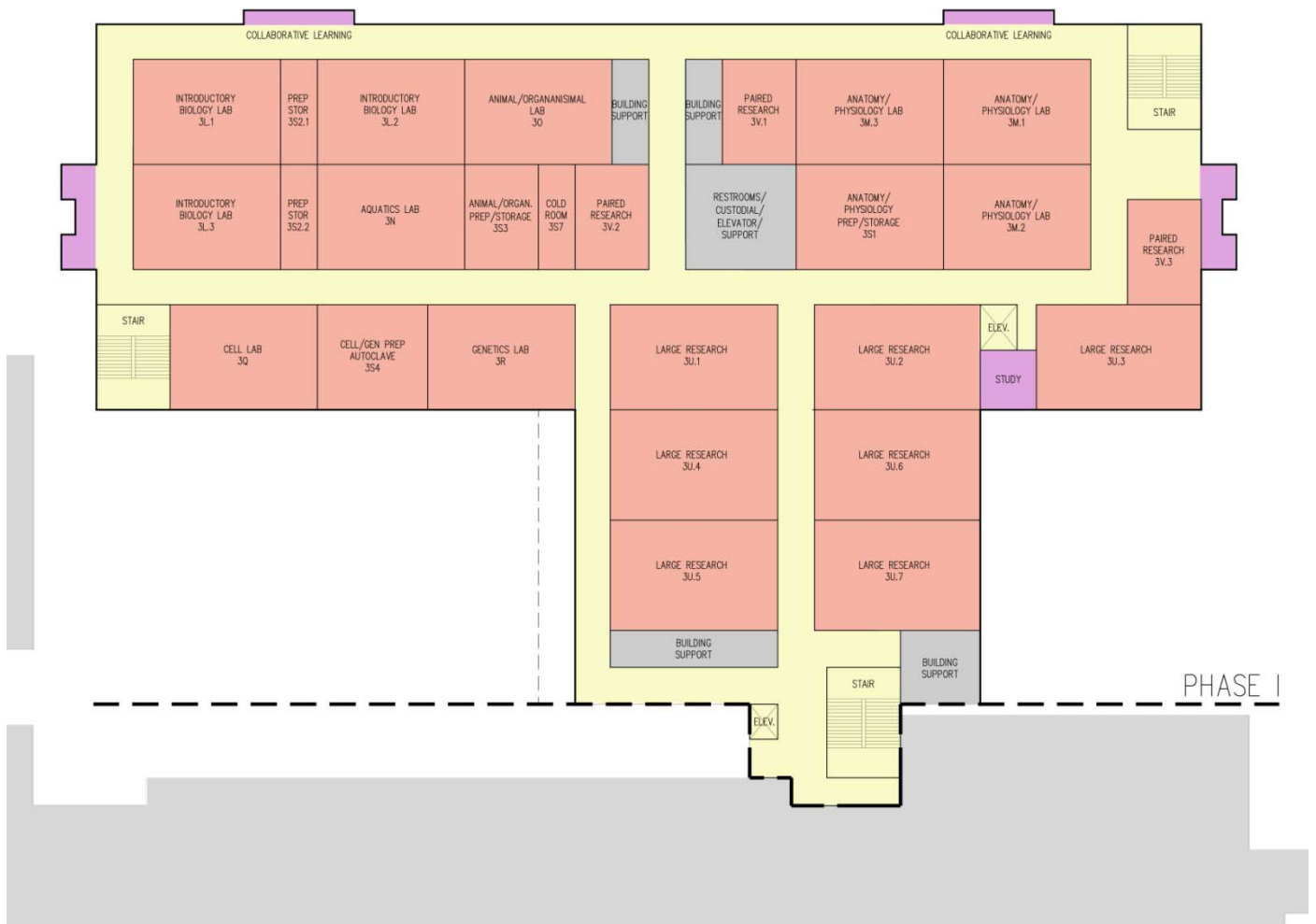
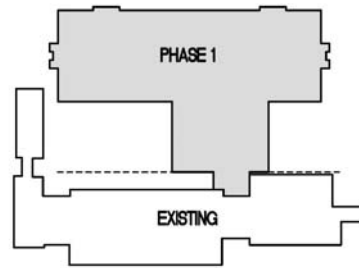

Second Floor Plan/Phase 1

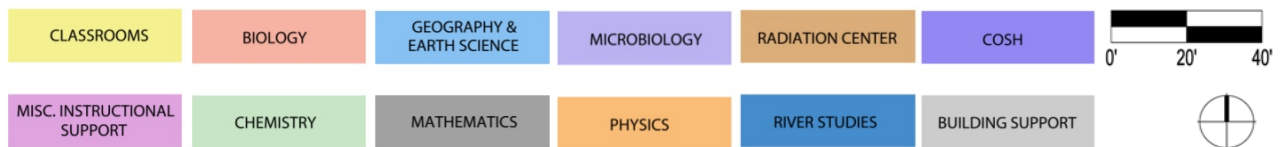

Division 5: Pre-Design Concept

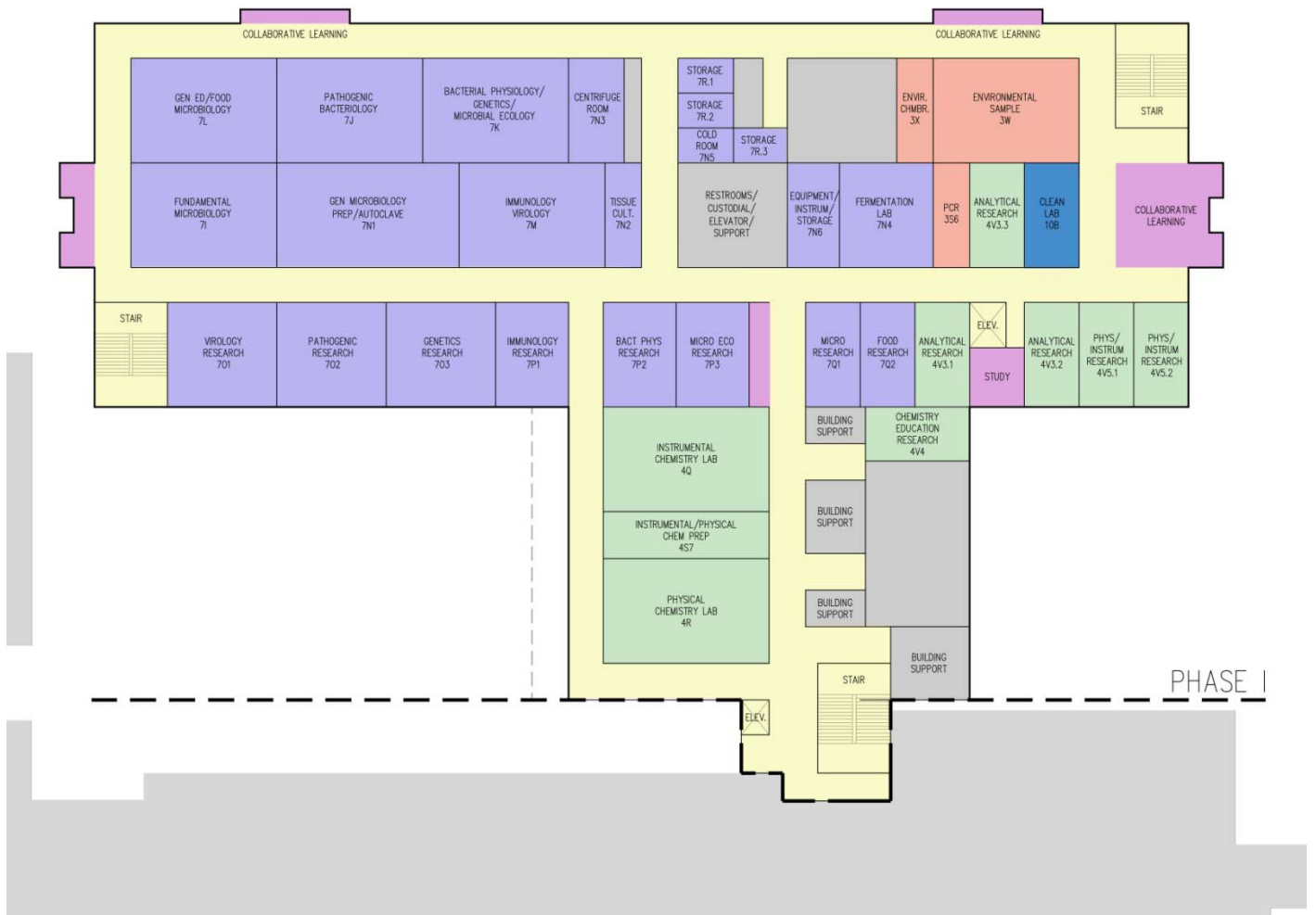
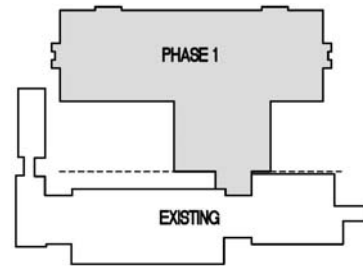

Third Floor Plan/Phase 1

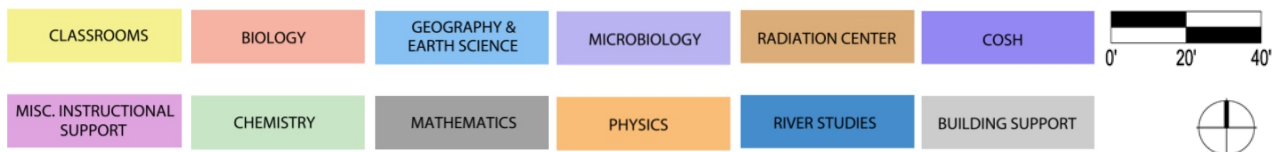

Division 5: Pre-Design Concept

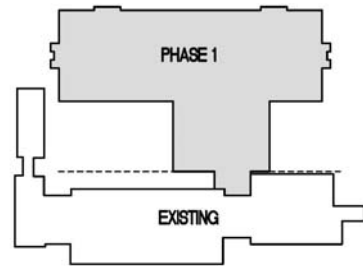

Fourth Floor Plan/Phase 1

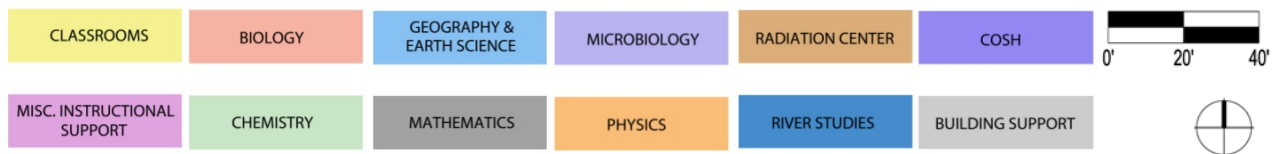

Division 5: Pre-Design Concept

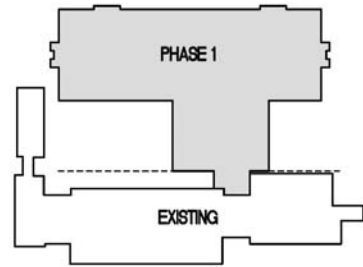

Basement Plan/Phase 1

CLASSROOMS	BIOLOGY	GEOGRAPHY & EARTH SCIENCE	MICROBIOLOGY	RADIATION CENTER	COSH	0' 20' 40'
MISC. INSTRUCTIONAL SUPPORT	CHEMISTRY	MATHEMATICS	PHYSICS	RIVER STUDIES	BUILDING SUPPORT	



Division 5: Pre-Design Concept

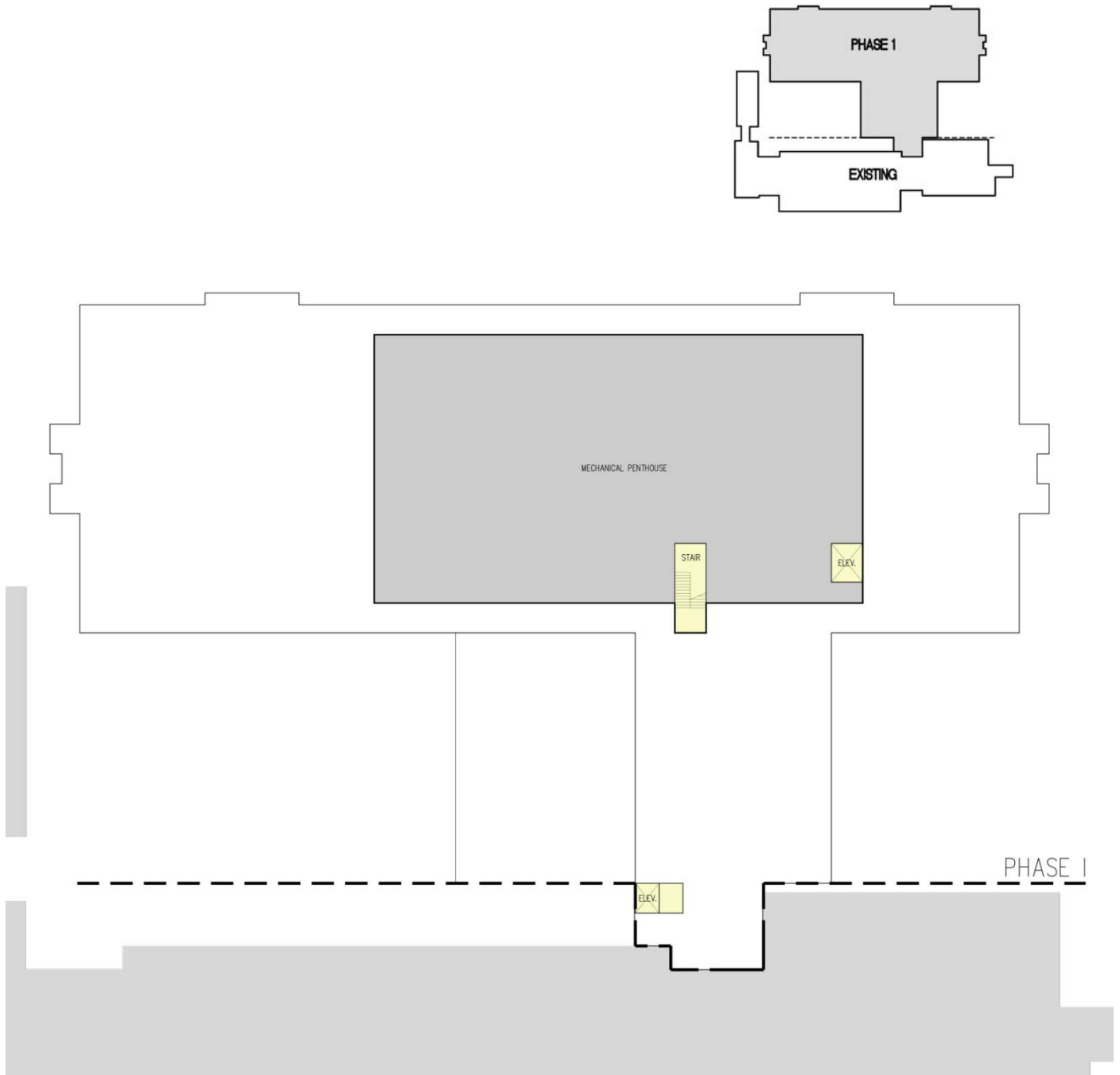

Fifth Floor Plan/Phase 1

CLASSROOMS	BIOLOGY	GEOGRAPHY & EARTH SCIENCE	MICROBIOLOGY	RADIATION CENTER	COSH	
MISC. INSTRUCTIONAL SUPPORT	CHEMISTRY	MATHEMATICS	PHYSICS	RIVER STUDIES	BUILDING SUPPORT	

Division 5: Pre-Design Concept

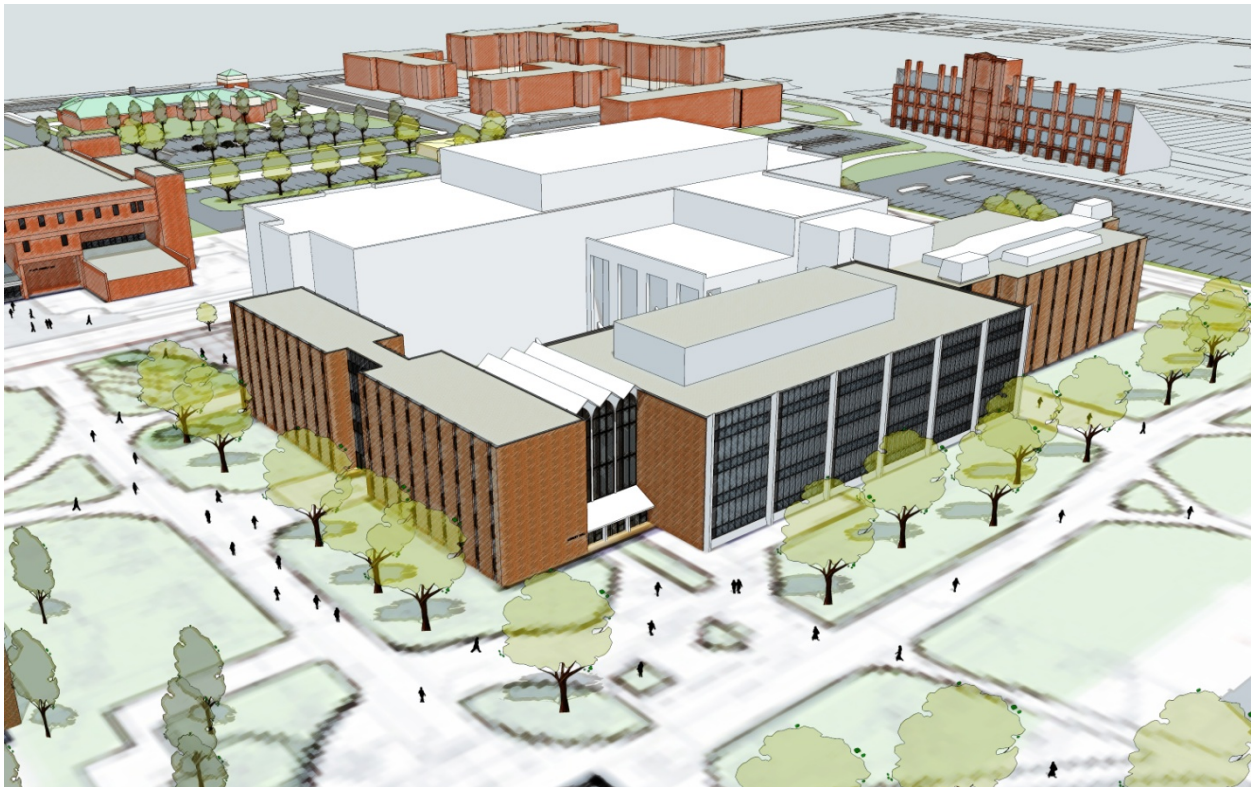
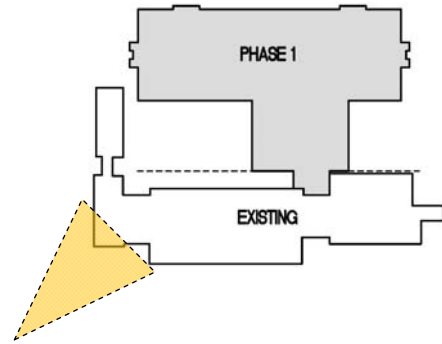

Southwest View/Phase 1

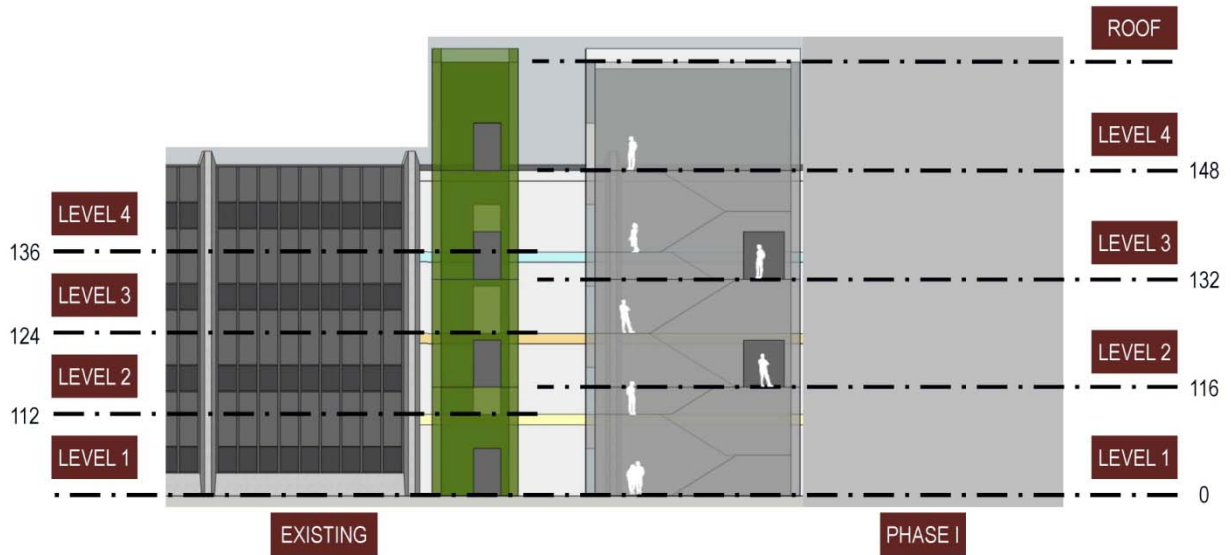

Link Connection

The Phase 1 link connection to the existing building addresses the vertical circulation challenges of connecting floor levels that don't align. The only direct floor level connection is at Level 1 (ground floor) and then a new stair and elevator make the differing floor level accommodations at Levels 2, 3, and 4.

Division 5: Pre-Design Concept

Phase 2 (New) Concept Plan Development:

- Faculty offices to be located at the exterior wall with support spaces, classrooms, and teaching labs located inboard in order to maximize exterior views and daylight for faculty and staff.
- Classrooms located on Levels 1-3.
- Dean’s Office located on Level 1.
- Shop and Field Equipment Storage located on Level 1 in order to provide direct access to the exterior.

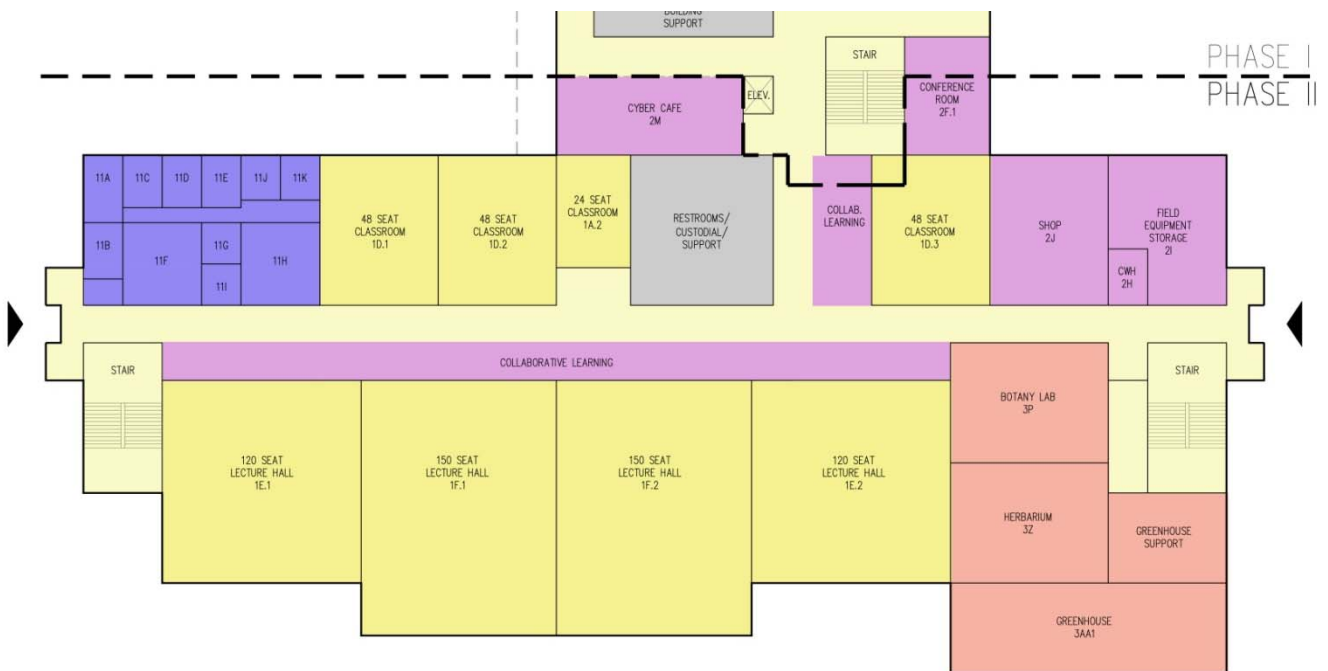
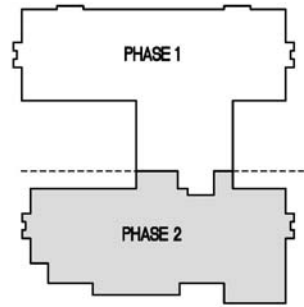

First Floor Plan/Phase 2
New Addition Option

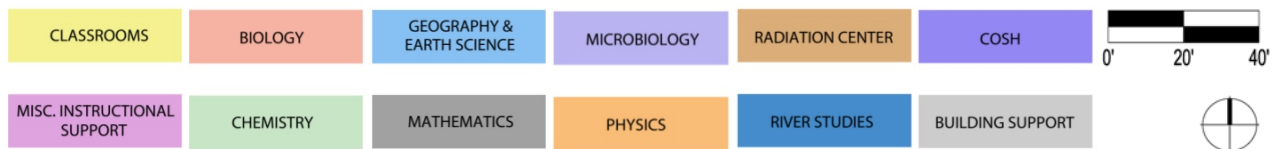

Division 5: Pre-Design Concept

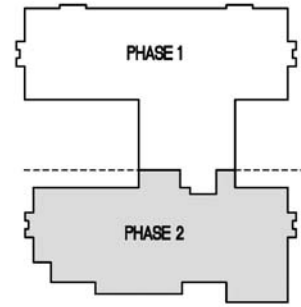

Second Floor Plan/Phase 2
New Addition Option

CLASSROOMS	BIOLOGY	GEOGRAPHY & EARTH SCIENCE	MICROBIOLOGY	RADIATION CENTER	COSH	0' 20' 40'
MISC. INSTRUCTIONAL SUPPORT	CHEMISTRY	MATHEMATICS	PHYSICS	RIVER STUDIES	BUILDING SUPPORT	



Division 5: Pre-Design Concept

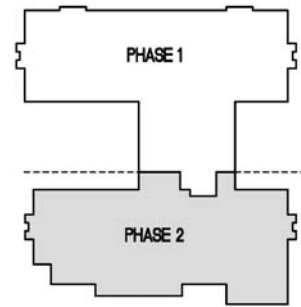

Third Floor Plan/Phase 2
New Addition Option

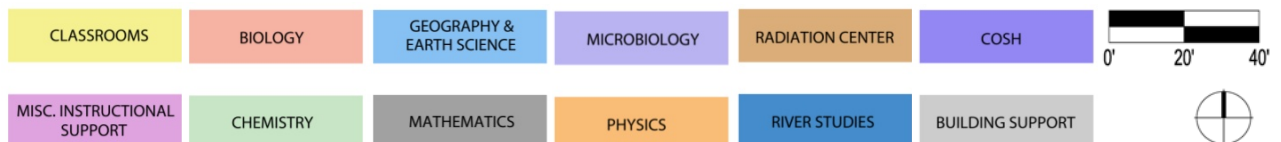

Division 5: Pre-Design Concept

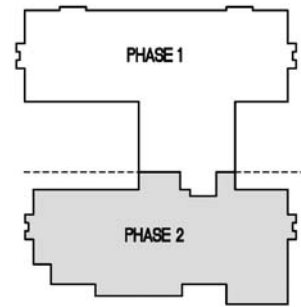

Fourth Floor Plan/Phase 2
New Addition Option

CLASSROOMS	BIOLOGY	GEOGRAPHY & EARTH SCIENCE	MICROBIOLOGY	RADIATION CENTER	COSH	0' 20' 40'
MISC. INSTRUCTIONAL SUPPORT	CHEMISTRY	MATHEMATICS	PHYSICS	RIVER STUDIES	BUILDING SUPPORT	



Division 5: Pre-Design Concept

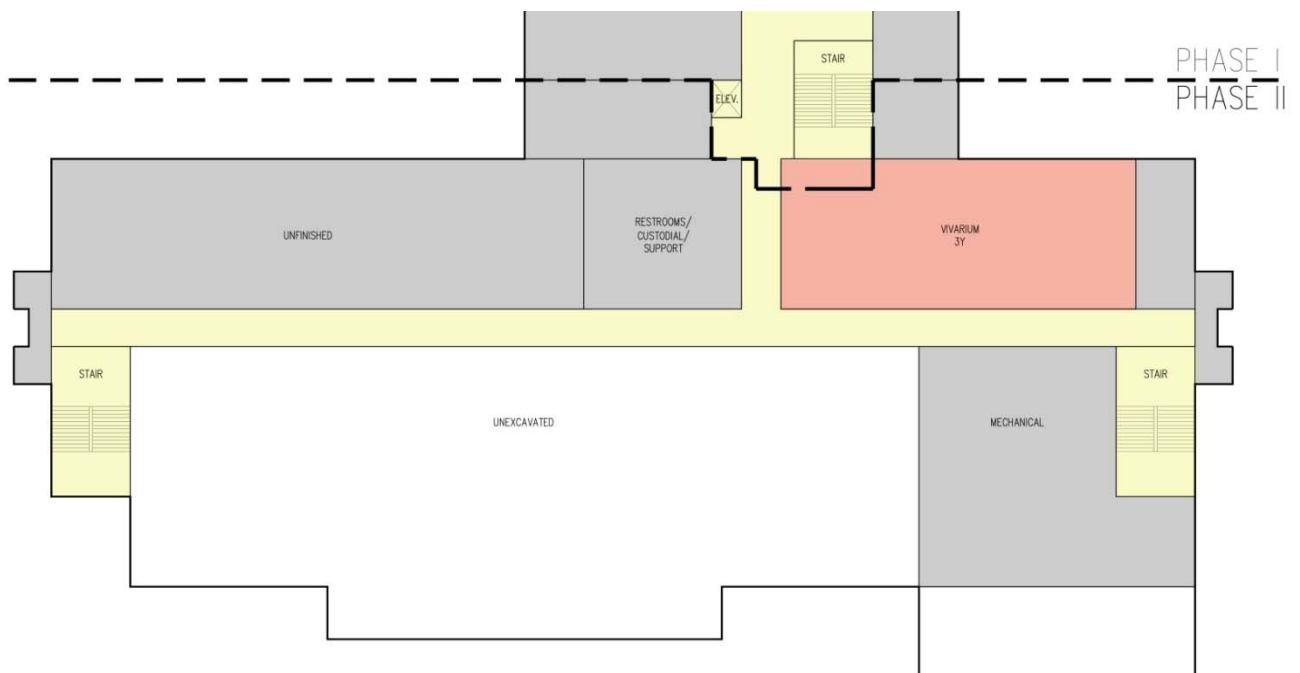
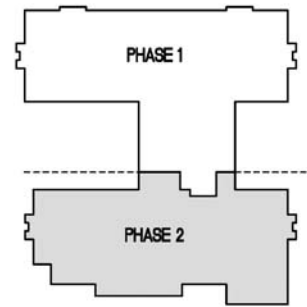

Basement Plan/Phase 2
New Addition Option

CLASSROOMS	BIOLOGY	GEOGRAPHY & EARTH SCIENCE	MICROBIOLOGY	RADIATION CENTER	COSH	0' 20' 40'
MISC. INSTRUCTIONAL SUPPORT	CHEMISTRY	MATHEMATICS	PHYSICS	RIVER STUDIES	BUILDING SUPPORT	



Division 5: Pre-Design Concept

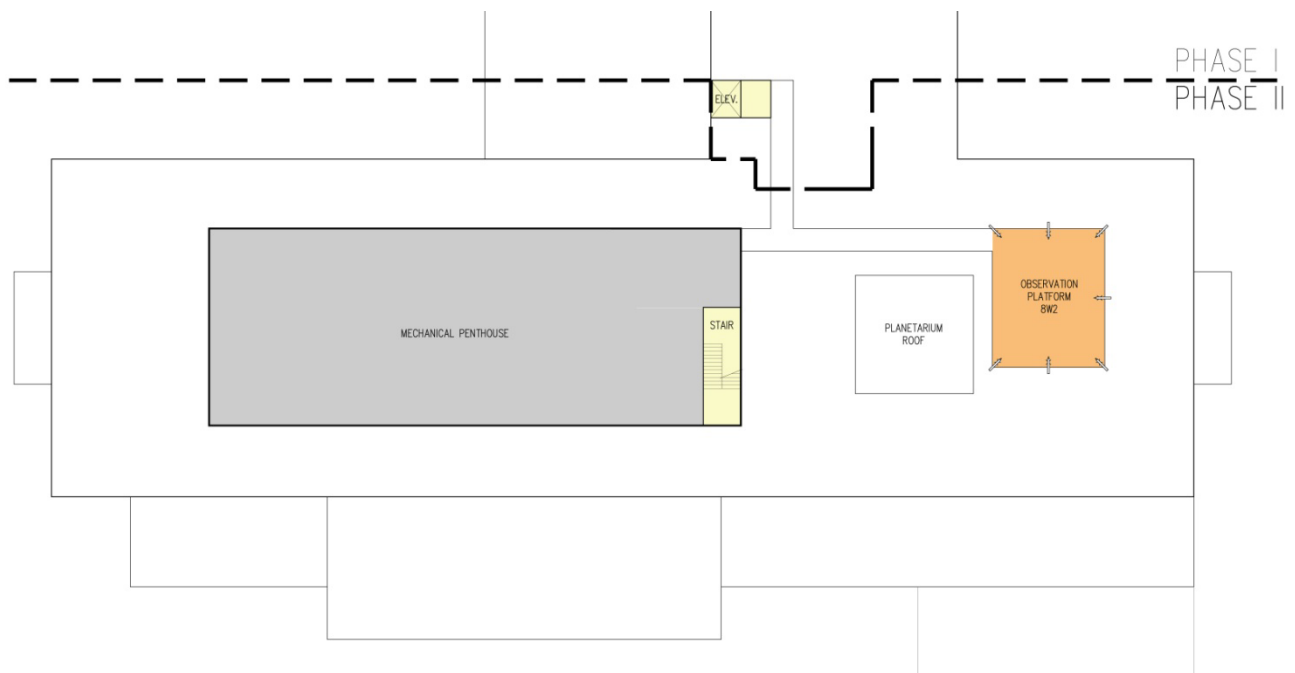
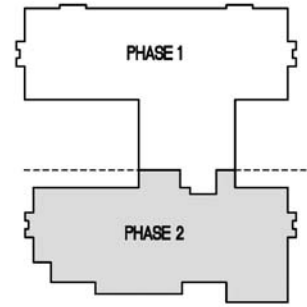

Fifth Floor Plan/Phase 2
New Addition Option

CLASSROOMS	BIOLOGY	GEOGRAPHY & EARTH SCIENCE	MICROBIOLOGY	RADIATION CENTER	COSH	
MISC. INSTRUCTIONAL SUPPORT	CHEMISTRY	MATHEMATICS	PHYSICS	RIVER STUDIES	BUILDING SUPPORT	

Division 5: Pre-Design Concept

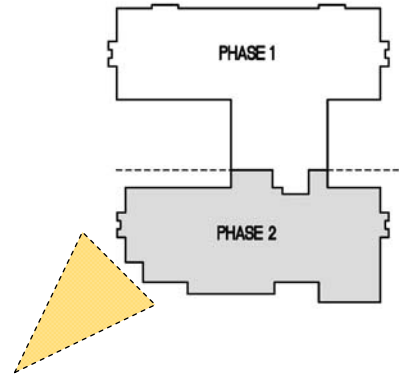

Southwest View/Phase 2
New Addition Option

Division 5: Pre-Design Concept

Phase 2 (Renovation & Addition) Concept Plan Development:

- Existing Planetarium to remain.
- Faculty offices to be located at the exterior wall with support spaces, classrooms, and teaching labs located inboard in order to maximize exterior views and daylight for faculty and staff.
- Classrooms located on Levels 1-3.
- Dean's Office located on Level 1.
- Shop and Field Equipment Storage located on Level 1 in order to provide direct access to the exterior.

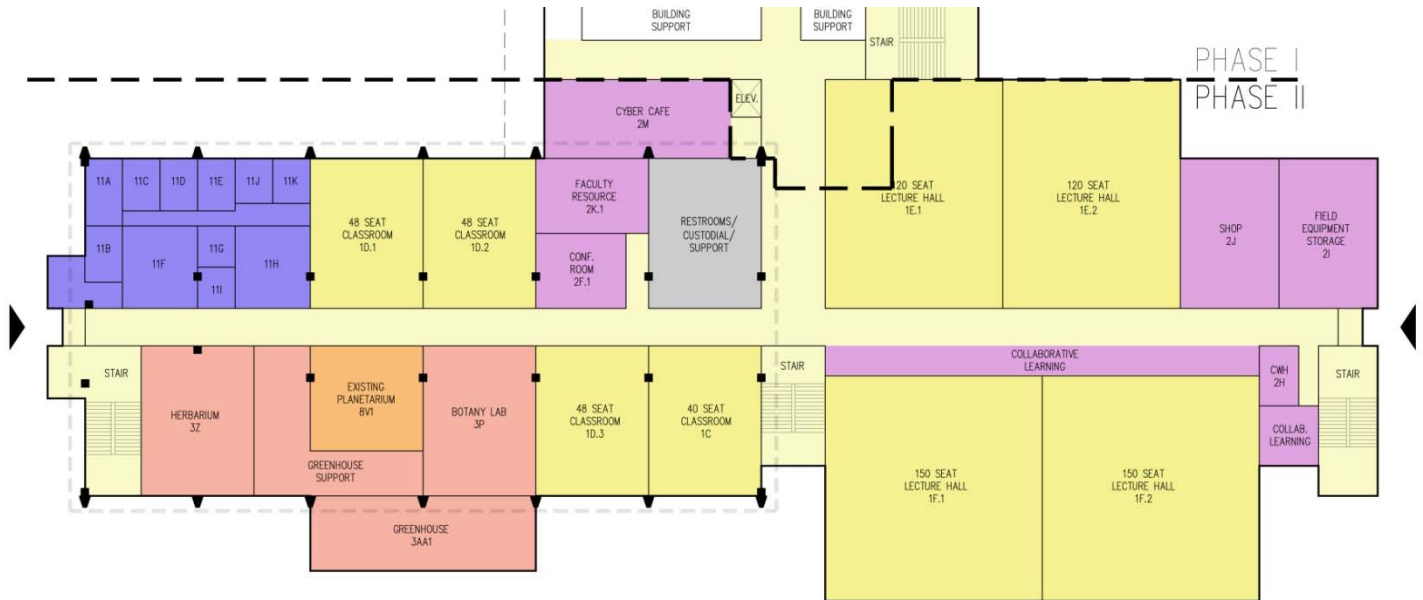
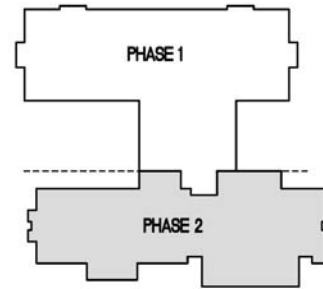

First Floor Plan/Phase 2
Renovation + Addition Option

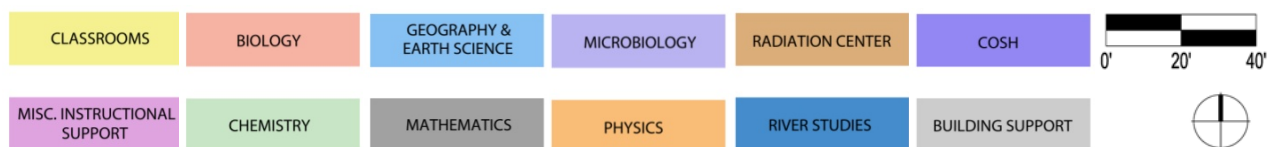

Division 5: Pre-Design Concept

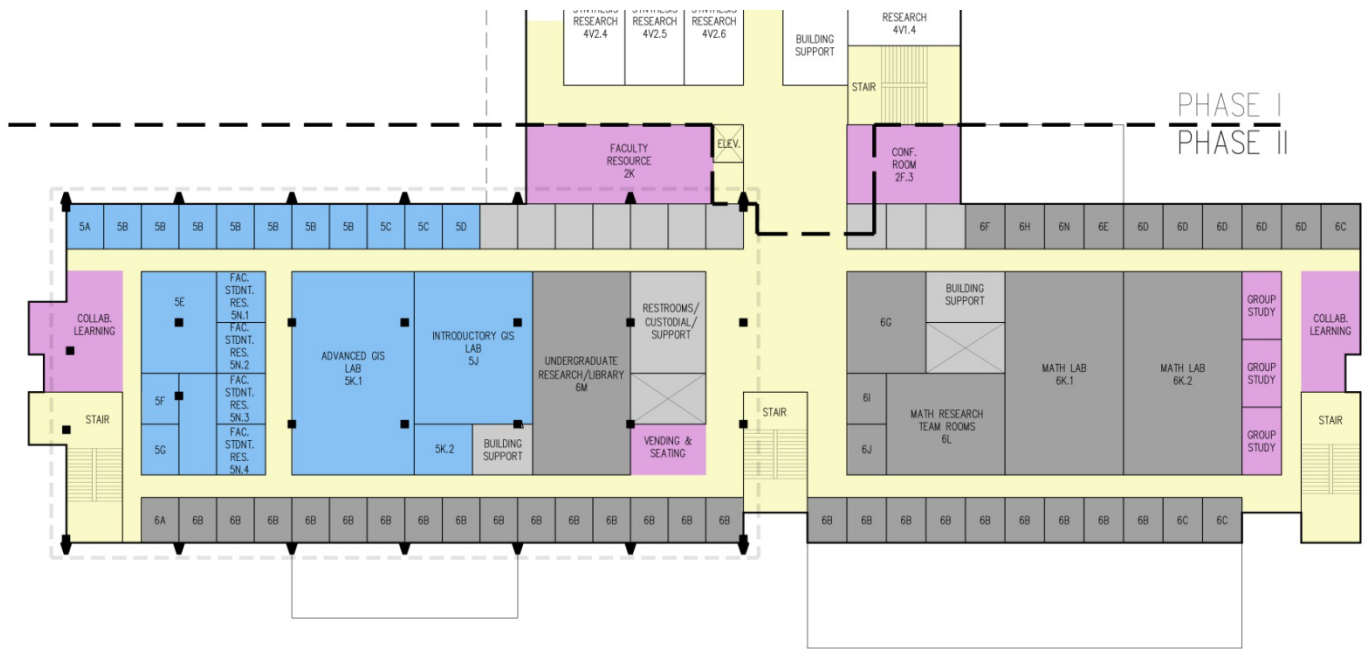
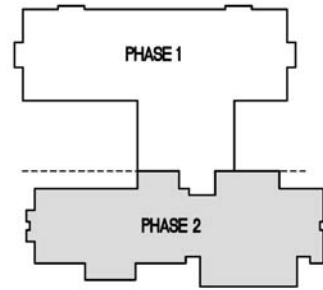

Third Floor Plan/Phase 2
Renovation + New Addition Option

CLASSROOMS	BIOLOGY	GEOGRAPHY & EARTH SCIENCE	MICROBIOLOGY	RADIATION CENTER	COSH	0' 20' 40'
MISC. INSTRUCTIONAL SUPPORT	CHEMISTRY	MATHEMATICS	PHYSICS	RIVER STUDIES	BUILDING SUPPORT	



Division 5: Pre-Design Concept

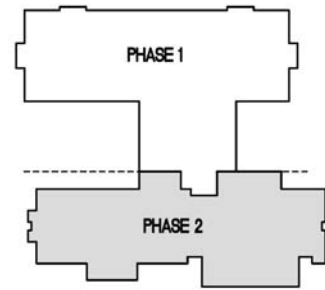

Fourth Floor Plan/Phase 2
Renovation + New Addition Option

CLASSROOMS	BIOLOGY	GEOGRAPHY & EARTH SCIENCE	MICROBIOLOGY	RADIATION CENTER	COSH	0' 20' 40'
MISC. INSTRUCTIONAL SUPPORT	CHEMISTRY	MATHEMATICS	PHYSICS	RIVER STUDIES	BUILDING SUPPORT	



Division 5: Pre-Design Concept

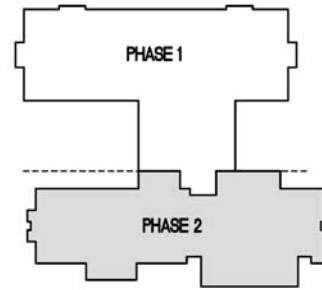

Basement Plan/Phase 2
Renovation + New Addition Option

CLASSROOMS	BIOLOGY	GEOGRAPHY & EARTH SCIENCE	MICROBIOLOGY	RADIATION CENTER	COSH	0' 20' 40'
MISC. INSTRUCTIONAL SUPPORT	CHEMISTRY	MATHEMATICS	PHYSICS	RIVER STUDIES	BUILDING SUPPORT	



Division 5: Pre-Design Concept

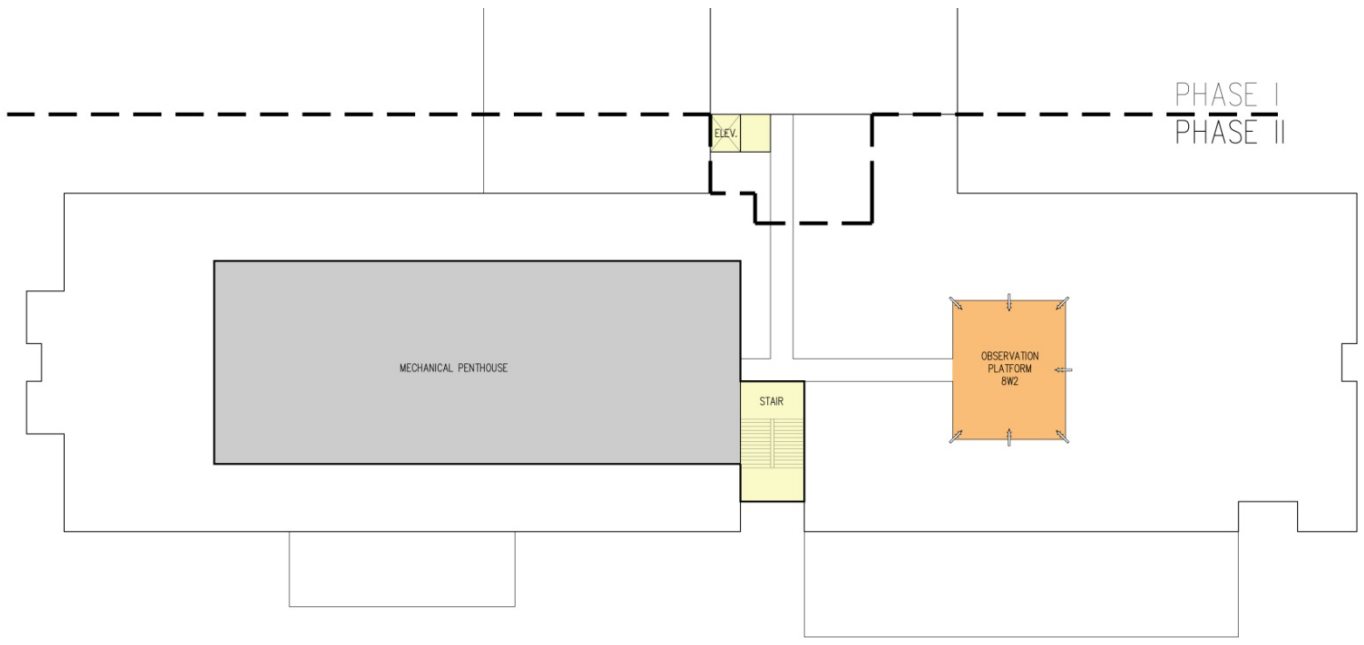
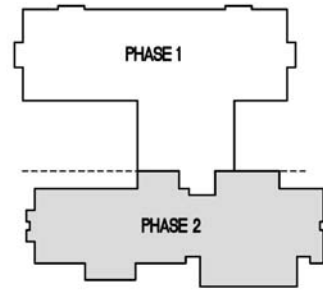

Fifth Floor Plan/Phase 2
Renovation + New Addition Option

CLASSROOMS	BIOLOGY	GEOGRAPHY & EARTH SCIENCE	MICROBIOLOGY	RADIATION CENTER	COSH	0' 20' 40'
MISC. INSTRUCTIONAL SUPPORT	CHEMISTRY	MATHEMATICS	PHYSICS	RIVER STUDIES	BUILDING SUPPORT	



Division 5: Pre-Design Concept

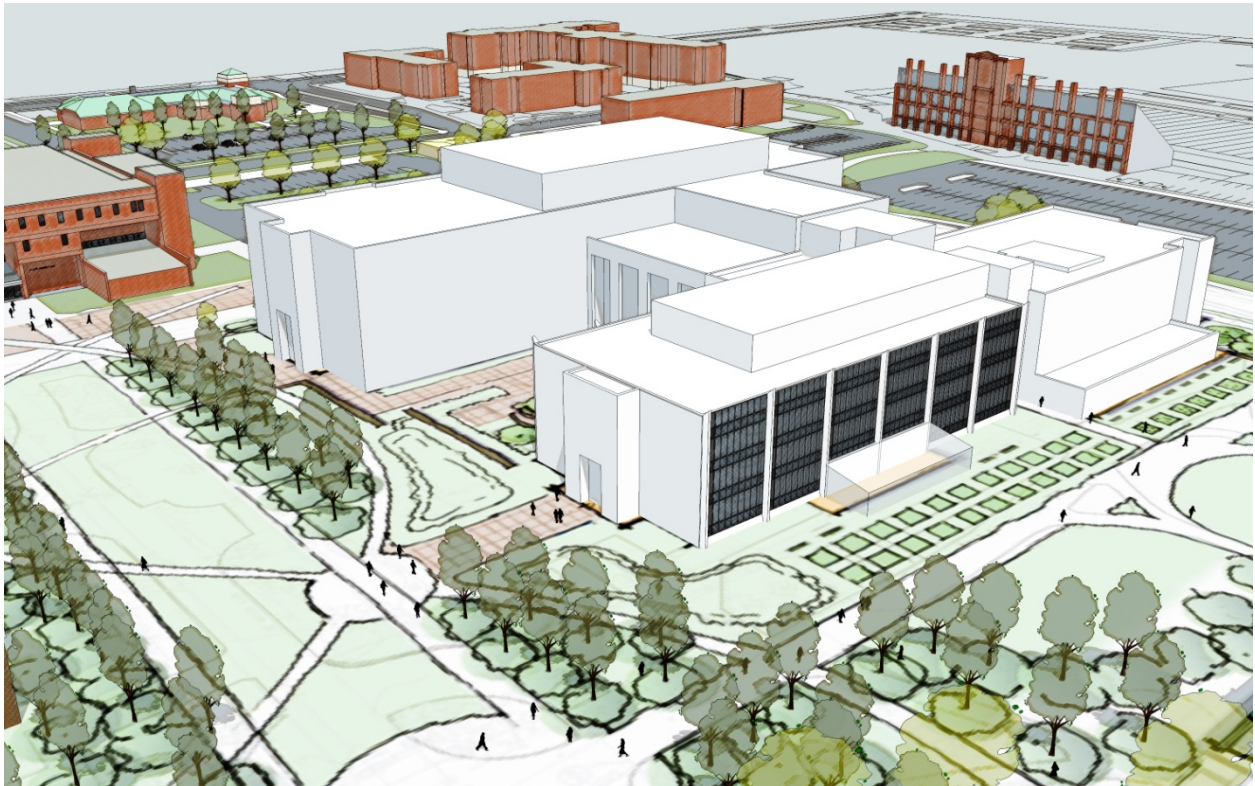
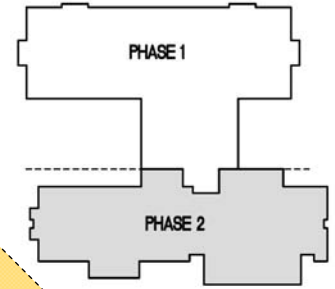

Southwest View/Phase 2
Renovation + New Addition Option

5.7 Laboratory Systems

5.7.1 Laboratory Modular Planning

Laboratories should be organized around modular planning principles so they are constructed with standardized units or dimensions for flexibility and a variety of uses. Modular planning is used as an organizational tool to allocate space within a building. The module establishes a grid by which walls and partitions are located. As modifications are required because of changes in laboratory use, instrumentation, or departmental organization, partitions can be relocated, doors moved, and laboratories expanded into larger laboratory units or contracted into smaller laboratory units without requiring reconstruction of structural or mechanical building elements.

The planning modules may be combined to produce large, open laboratories or subdivided to produce small instrument or special-use laboratories.

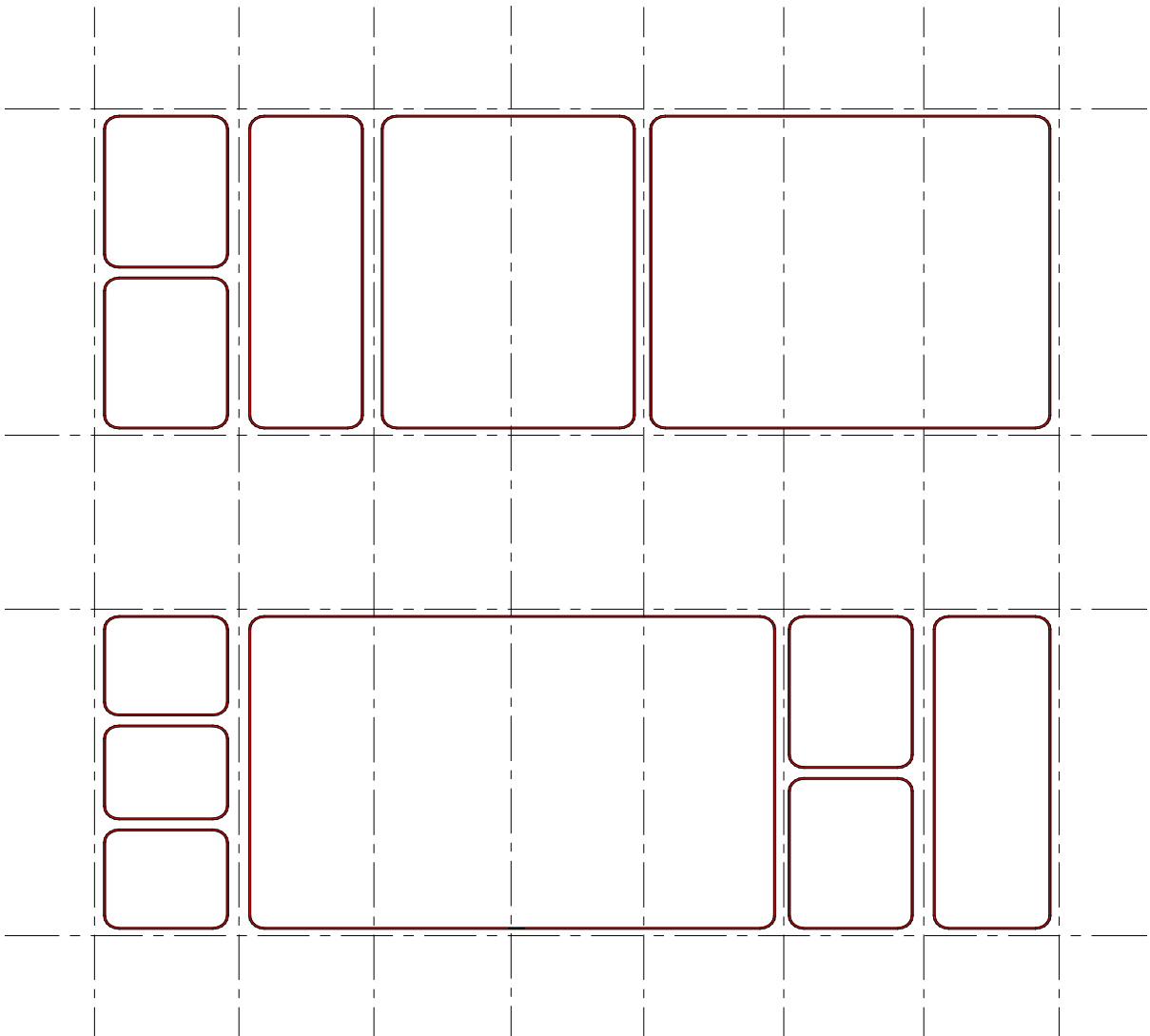

The above description of the planning module also includes the organized and systematic deliveries of laboratory piped services, HVAC, fume hood exhaust ducts, power and signal cables. If these services are delivered to each laboratory unit in a consistent manner, then changes in laboratory use requiring addition or deletion of services will be easy to accomplish because of the constant nature of the infrastructure.

Division 5: Pre-Design Concept

The proposed laboratory planning module for this project was derived by analyzing the laboratory bench, equipment, and circulation space required for the laboratory functions. The module is based on the bench space (width and length) required for technical work stations, instruments, and procedures. The space required between benches is designed to allow people to work back-to-back at adjacent benches, to allow for accessibility for disabled and still allow for movement of people and laboratory carts in the aisle.

A planning module approximately 10'-6" wide by 30'-0" deep is recommended for the laboratory spaces. This module will provide adequate bench space plus space for floor standing equipment and fume hoods, and can be divided for smaller support spaces such as equipment and instrument rooms.

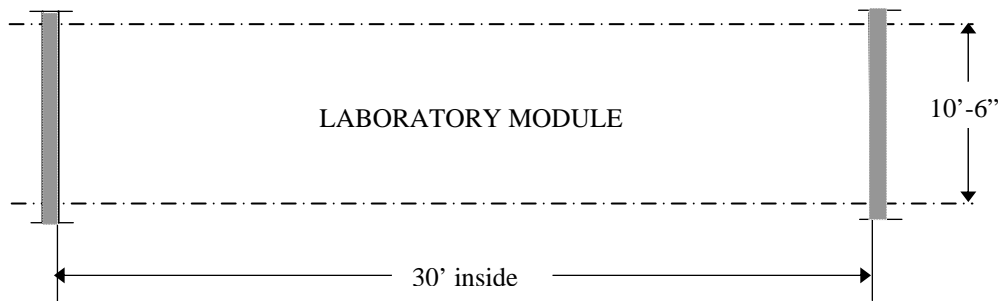

Island benches which are 5'-0" wide and wall benches 2'-6" deep are recommended to accommodate the anticipated instruments to be used in the project laboratories.

A 5'-0" minimum aisle between benches will minimize circulation conflicts and reduce potential safety hazards. It is critical in all laboratory spaces that carts be able to maneuver without conflict in all aisles.

The proposed module width will accommodate the above requirements and will provide sufficient space in laboratories when movable computer stations or equipment racks are used near laboratory benches.

5.7.2 Circulation

Effective circulation is an important element in the design of the laboratories. Materials delivered to the facility will include chemicals, supplies and equipment. In addition to material delivery, the debris and waste generated by the laboratory's functions must be safely removed on a periodic basis.

Internal building circulation should provide safe pedestrian egress from each individual laboratory and laboratory support space through an uncomplicated path of egress to the building exterior at grade. The circulation system should accommodate the preferred adjacencies identified for the relationships between:

Laboratories and laboratory support spaces.

Laboratories and offices.

Other features that should be considered in the design of the circulation system include:

At least one door into each laboratory space should have a minimum 54" wide clear opening. This can be accomplished using openings with 3'-0" active leaf and one 1'-6" inactive leaf.

Equipment lists should be carefully reviewed to verify that individual pieces of equipment can be transported and maneuvered between spaces. Future equipment should be anticipated.

Interior circulation corridors should be a minimum of 6'-0" in width.

Doorways accessing corridors should open into recessed alcoves serving the corridor. The doors should swing out from laboratories, in the direction of exit.

Circulation and fume hood locations within laboratory spaces should be coordinated to preclude exiting in front of the fume hoods.

5.7.3 Interaction

Design to encourage interaction is fundamental to a successful science teaching facility. There are four basic aspects of interaction concern:

- With each laboratory group
- Intra-departmental
- Inter-departmental
- Between institutions.

This requires that spaces be created within laboratories, between laboratories, on each floor, and in public areas of building. These areas for formal and, in particular, informal interaction will be linked to the circulation schemes. Concepts should be developed as part of the design process that would directly support these objectives.

Formal Interaction Considerations

AMENITIES

- Conference rooms
- Lecture theatre

PLAN CONFIGURATIONS

Smaller spaces should be located close to laboratories; larger spaces can be remote.

Informal Interaction Considerations

AMENITIES

- Casual meeting/interaction spaces for short duration interaction.
- Restaurant and coffee bar provide opportunity for moderate during informal interactions.
- Outdoor gathering spaces should be highly visible and inviting.
- Display/announcement boards serves as gathering places for informal contact.
- Connections to other campus facilities will facilitate interaction with researchers and staff in nearby buildings.

PLAN CONFIGURATIONS

- Side-by-side connections of laboratories; cross corridor laboratory connections; and through laboratory support space connections.
- Shared support spaces (equipment and instrument rooms) close to laboratories.
- Link between outdoor gathering spaces and interior interaction spaces.
- Inviting and visible horizontal and vertical circulation systems can also serve as interaction spaces. Circulation systems shall encourage sharing of support functions.

5.7.4 Noise Control

Noise control requires specific attention to design and construction details. The following features should be addressed in the design of the mechanical and electrical systems:

Fan noise transmitted to spaces through the duct system or through the building structure. This noise is characterized by a low-frequency rumble and often includes annoying pure tones.

Noise generated by the excitation of duct wall resonance produced by fan noise, by pressure fluctuations caused by fan instability, and by high turbulence caused by discontinuance in the duct system.

Noise generated by air flowing past dampers, turning vanes, terminal device louvers, and comprising mid-to-high frequency energy.

Water circulation system noise caused by high velocities or abrupt pressure changes and is generally transmitted through structural connections.

Noise and vibration caused by out-of-balance forces generated by the operation of fans, pumps, compressors, etc.

Magnetostrictive hum associated with the operation of fluorescent lighting ballasts, transformers, or electric motors.

Elevator equipment noise from motor generators, hoist gear, and counterweight movement; or from hydraulic pump systems.

Other design precautions include:

Conduits should not directly link noise-sensitive spaces, nor should they mechanically bridge vibrationally-isolated building elements using a rigid connection.

Flexible conduit must be used for connections to isolated floor slabs, walls, and vibrationally isolated mechanical/electrical devices.

Duct silencers will be considered when duct distance is not sufficient to provide adequate acoustical separation.

Generally, laboratory spaces should satisfy the following preliminary requirements:

Space	Noise Isolation	Noise Criterion
Laboratories	n/a	NC 45
Laboratory Support Room	n/a	NC 45
Imaging Rooms	STC 50	NC 40
Holding Rooms	STC 45	NC 40

These values do not take into account adjacencies that may be incompatible; the design should be evaluated for incompatibilities, and additional mitigation provided, as required.

Noise levels should be less than NC 50 at a distance of 36 inches from fume hoods.

Division 5: Pre-Design Concept

5.7.5 Animal Facilities

The American Association for Accreditation of Laboratory Animal Care (AAALAC) is accepted by the National Institutes of Health as an assurance that the animal facilities are in compliance with Public Health Service Policy. To meet these guidelines, several organizational features should be incorporated in the design to ensure separation of species or isolation of individual projects when necessary, to allow the reception, quarantine and isolation of animals, and to provide animal housing.

Animal Facility will be designed to meet the biological needs of all categories of animals, protection, adequate freedom of movement, rest and access to food and water, based on the ILAR guidelines.

5.7.5.1 Animal Room Construction Features

WALLS

Walls should be free of cracks, utility penetrations, or imperfect junctions with doors, ceilings, and corners. Surface materials will be capable of withstanding scrubbing with detergents and disinfectants and of withstanding the impact of 180 degree water under high pressure. Provision should be made for protecting walls from damage by movable equipment.

CEILINGS

Ceilings will be smooth, waterproof, and free of imperfect junctions. Surface materials will be capable of withstanding scrubbing with detergents and disinfectants. Furred ceilings of plaster or fireproof plasterboard will be sealed and painted with a washable finish.

FLOORS

Floors will be smooth, waterproof, non-absorbent, non-slip, wear-resistant, acid and solvent-resistant, not susceptible to the adverse effects of detergents and disinfectants, and capable of supporting racks, equipment, and storage areas without becoming gouged, cracked or pitted. Depending on the functions carried on in specific areas, floor materials will be monolithic or have a minimum of joints.

CORRIDORS

Corridors will be at least 7 ft. (2.1 m.) wide to facilitate the movement of personnel and equipment. Floor-wall junctions will be coved to facilitate cleaning. Provisions will be made for curbs, guardrail, or bumpers to protect the walls from damage. Exposed corners will be protected with durable corner guards.

DOORS AND WINDOWS

Doors will open into the animal rooms and should be at least 42 inches wide and at least 84 inches high to permit easy passage of racks and equipment. Doors will fit tightly within their frames and both will be completely sealed to provide a barrier to prevent the entrance and harboring of vermin. Self-closing doors are required for containment in rooms where hazardous agents are used. Doors will be provided with spring loaded sweeps to seal when closed. Doors shall be hollow metal or stainless steel, sealed, moisture proof, rust proof, and damage resistant.

The doors shall have recessed hardware and shall be self-closing and self-locking, designed to open from the inside without key. Viewing windows with slides will not exceed 6" in width or 18" in height.

Exterior windows and skylights shall not be provided in animal rooms.

CAGE WASH

This area will be designed for clean/dirty operation. Equipment will include cage washer, rack hose down bay and other equipment such as acid wash sinks with canopy hood or low slotted exhaust, floor drains will be provided. 36" wide double-swinging doors are required.

SHOWER AND LOCKER

Shower and locker facilities will be provided.

5.7.5.2 Ventilation

The ventilation system must provide adequate environmental quality to ensure the health and well-being of animals necessary to validate the results of experimental studies.

The design tasks of HVAC system are:

- Control of odors
- Control of airborne contaminants
- Prevention of cross contamination
- Temperature/humidity control
- Reliable operation

The animal facility and human occupancy areas should be conditioned by separate air handling units and exhaust systems. Offices and spaces of sole human activity in the animal facilities should be zoned separately from the animal spaces.

30% efficiency prefiltration and 90% final filtration of the supply air will provide a satisfactory quality of animal environment. A positive pressure of the animal facility with respect to the outside environment is recommended.

Ventilation flow rates should result from one of the following criteria:

- Cooling load from animals and equipment,
- Minimum air changes per hour required for each space.

A minimum ventilation of 15 air changes per hour is required in each animal room space for the purpose of odor control.

Supply air should be 100% fresh air in all areas, with no recirculation, provided by a constant volume terminal reheat device. Animal rooms may require terminal booster humidification.

Supply and exhaust air systems should be sized to minimize noise level.

5.7.5.3 Controls

All vivarium rooms will have individual temperature and humidity control.

5.7.5.4 Piping and Plumbing

The following piped systems will be required for the new facility:

- Potable Hot and Cold Water (HW, CW)

Potable water system should be looped through each floor of the building providing services as required by Programmatic Room Diagrams. All fittings shall be fitted with vacuum breakers. Piping should be copper. 140° F water is desirable for cagewashing equipment.

- Reverse Osmosis Water (RO)

RO water should be available in the animal facility. The RO water system will meet the requirements of Class III water as defined by the College of American Pathologists. The RO water center should provide purified water for an automated bottle-filling station and for the animal watering system. No deionization should be used prior to or after RO treatment. The water source for RO center should be the pretreated facility potable water.

The RO system should include stainless steel pump, RO cartridges, flow block and control package for a fully automatic operation and interface with external equipment.

RO water will be held in a storage tank appropriately sized to meet the animals' drinking requirements as well as temporary interruptions of water supply.

RO water piping will be designed as a recirculating system. Water will be pumped in a closed loop and single line branches for automatic watering system in each Animal Room and Holding Room. Piping should be CPVC.

- Sanitary Waste

Sanitary waste system should be cast iron.

Floor drains may not be essential in all animal rooms, particularly those housing rodent species. Floors in such rooms can be maintained satisfactorily by wet vacuuming or by sweeping and mopping with appropriate disinfectants or cleaning compounds.

If provided, floor drains should be at least 6 inches in diameter and will be primed. Floors will be sloped. The recommended minimal pitch of floors is 0.25 inches/yard. All drainpipes should have short runs to the main or be steeply pitched from the opening. When drains are not in use, they should be capped and sealed to prevent backflow of sewer gases. Lockable drain covers are advisable to prevent the use of drains for disposal of materials that should be swept up and removed by other means. Drains should have removable strainers for disposal of solid waste.

5.7.5.5 Power and Lighting

Each animal room should be supplied by a separate power panel located in corridor. Power distribution within the new facility should be conduit and wire from a main distribution panel to the room panel.

The electrical system should provide appropriate lighting, sufficient power outlets, and safety lighting. All outlets shall be standard type with waterproof covers to allow for cleaning. Light fixtures shall be sealed water tight units.

STANDBY POWER

Standby power should be provided for HVAC system so that operation can be continued, even at reduced capacity, in event of failure of the primary system. Standby power should be provided by a generator sized to maintain operation of Animal Room lighting, air supply, air exhaust, animal watering system and data gathering system. The capacity of the generator fuel supply should be discussed with Animal Facility Director.

EMERGENCY POWER

Lighting and alarms associated with the life safety requirements will be provided with emergency power by a local generator.

5.7.5.6 Noise and Vibration

Excessive levels of noise and vibration could affect both human and animal activities.

Animal Cubicle Rooms and Holding Rooms should be located away from building sources of noise or vibration such as elevators or mechanical rooms. Cage washing and refuse disposal should be carried out in rooms separated from those for animal housing.

Magnetostrictive hum associated with the operation of fluorescent lighting ballasts, transformers or electric motors should be minimized.

5.7.5.7 Environmental Monitoring and Control System

An environmental monitoring system should be implemented providing the following minimal services:

- Temperature, humidity, lighting and air flow monitoring.
- Lighting control.
- Electric door locks control.
- Alarm notification to a central computer, telephone sets, system printer and visual and audible remote locations.
- Telephone communications linked to the building phone system.

Division 5: Pre-Design Concept

Preferably, the environmental monitoring system is independent of the Building Management System (BMS). A BMS is designed to monitor and control the HVAC for the entire building and typically is not a true source of data or regulatory compliance. A vivarium environmental monitoring system (EMS) is designed to collect data and provide alarm notification for specific environmental inputs. A vivarium system requires monitoring for each room. The data must be easily and readily accessed by animal care personnel, and have the ability to produce standard reports to satisfy regulatory requirements, and for the use of the investigators in the facility. The BMS and EMS systems shall use the same sensors with the BMS system monitoring the results.

The features of a monitoring system are illustrated in the diagram below.

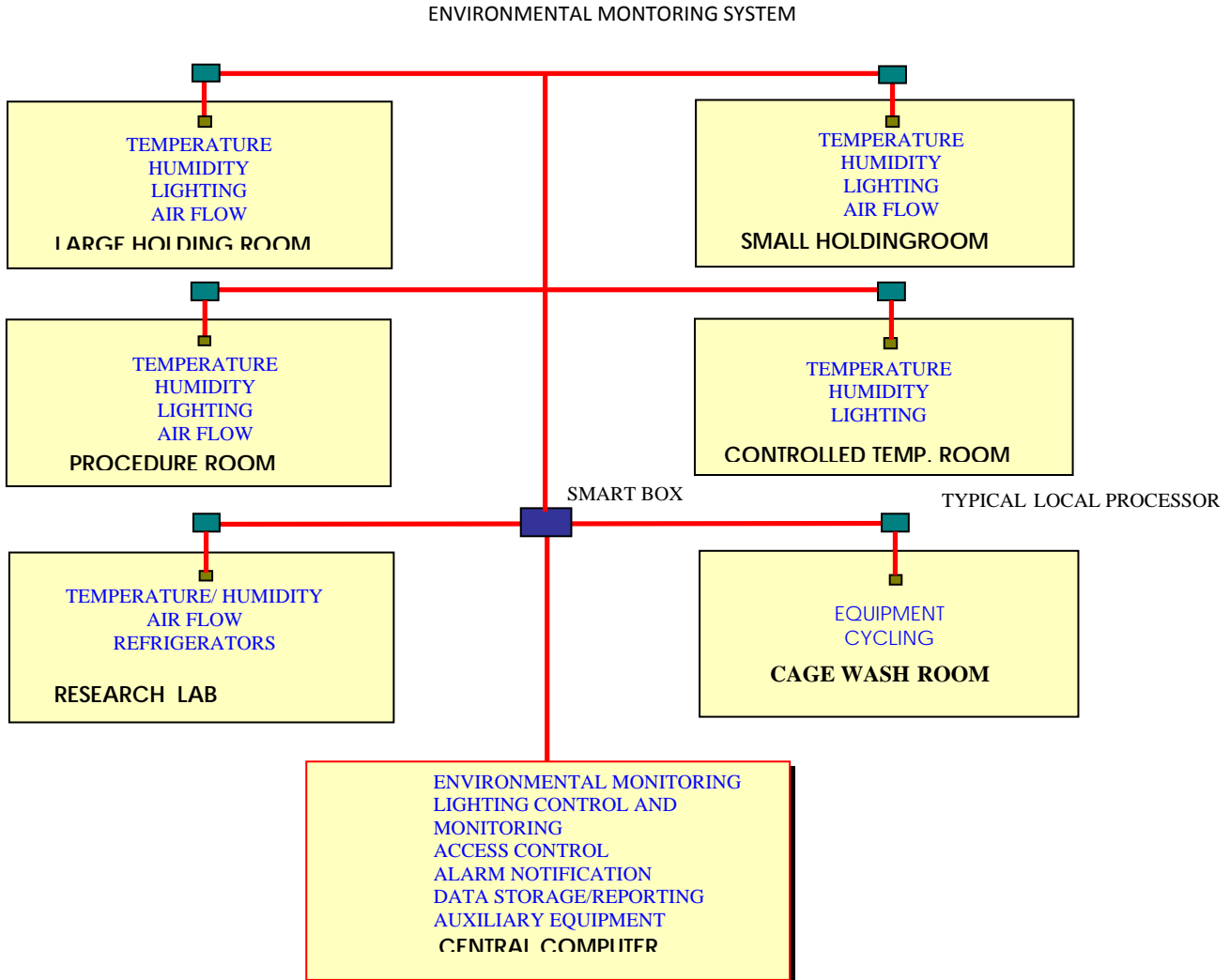

Division 5: Pre-Design Concept

5.7.5.8 Designated Spaces: Animal Holding Rooms

VENTILATION

Holding rooms should be designed to provide either positive or negative pressure relative to the corridor. The air flow rate will not change regardless of the balance inside the holding room. The minimum supply air required for each room should be ensured regardless the balance.

A higher quality microclimate separating selected small animals from the animal room or cubicle and the research personnel from animals, will be achieved in two ways:

- Microisolator systems consisting of closed cages individually supplied with HEPA filtered air. Cages are provided with filter top frame and can optionally be connected to an exhaust unit.
- Ventilated animal racks in which HEPA filtered air is distributed over cages. Exhaust air is released inside the room or into the room exhaust system.

Ventilation flow rates for the total air flow must remove sensible and latent heat from the animals as well as heat generated by electrical equipment. The species of animals, their weight and animal room population must be considered.

Recommended dry bulb temperature in animal holding rooms is 65° F to 79° F at a relative humidity of 40% to 60% based on the AHU 100% make up air unit.

Temperature difference between supply and return air temperature in cubicles should be maintained below 7° F.

A minimum ventilation rate of 15 changes per hour is required for the purpose of odor control.

Supplied air to the room should be 100% fresh air.

Supply air should be provided by a constant volume supply air duct and terminal reheat device with terminal booster humidification serving each holding room.

Air distribution should not cause drafts on research animals. Ceiling mounted, low velocity, low throw, stainless steel diffusers should be used.

The exhaust air grills must be resistant to water and placed at minimum eight inches above the floor to minimize the possibility of contact with water used to clean the floor. Stainless steel grills with thumbscrew fasteners should be provided with minimum 30% efficiency, easily removeable disposable filters mounted behind the grill. Joints around diffusers and grills should be sealed and gasketed.

Exposed duct work should be avoided. Supply and exhaust air systems should be sized to minimize noise level.

Temperature should be controlled by a room thermostat placed inside the animal holding room and connected to the reheat coil control valve to maintain dry bulb conditions.

A room humidistat should provide a minimum relative humidity of the space. The humidistat and thermostat should have the same location. Discuss in the DD phase, the need for individual room humidifiers.

PIPING AND PLUMBING

The following laboratory piped systems will be required for the new facility:

- Potable Hot and Cold Water (HW, CW). Each animal room should be provided with a scrub sink supplied with hot and cold water. The sink should be stainless steel, sealed to the wall with no exposed pipes or case work underneath. Each animal room will contain a hose bib with hot and cold water. All fittings shall be fitted with vacuum breakers
- Reverse Osmosis Water (RO). A single line branch will be connected from RO distribution system for each Animal Room for automatic watering system.

Division 5: Pre-Design Concept

POWER AND LIGHTING

Two 120-Volt duplex receptacles per each cage rack should be mounted in each room on the side wall at least 60 inches off the floor. One standby receptacle should be provided for each cage rack in the cubicles.

All outlets shall be standard type with waterproof covers to allow for cleaning.

Light will be uniformly distributed in each room. Ceiling light fixtures of fluorescent, diffuse type, should be recessed mounted, triple gasketed and sealed water tight.

Lighting will provide a two-stage light intensity. The lower light intensity of 30 foot candles three feet off the floor is adequate for routine animal housing. The higher intensity of 60 foot candles three feet off the floor would be utilized while observing the animals or servicing the room. Light timing capabilities shall be provided by the environmental control system, allowing programming of various light cycles. A 30 minutes override switch shall be provided.

5.7.5.9 Designated Spaces: Procedure Room

PROCEDURE ROOM

Procedure Room should operate under negative pressure with respect to the corridor.

Recommended dry bulb temperature is 72 +/- 3F at a relative humidity of 45 +/- 15% based on AHU 100% outside make up air system.

Minimum supply air flow rate should provide 15 changes per hour.

Supply air should be 100% outside air, provided by a constant volume supply air duct and terminal reheat device with terminal booster humidification.

Supply air shall be provided by ceiling Total Air Diffusers (TAD) or surgical air diffuser. Air will be exhausted through stainless steel grilles, with 30% efficiency filters, placed maximum eight inches above the finished floor.

Supply and exhaust air systems should be sized to minimize noise level and should not be exposed.

Potable Hot and Cold water, Purified water, Laboratory gas, Laboratory vacuum and Laboratory air will be supplied.

DI water will be supplied to the Procedure Room. A DI unit fed with RO water will be installed in the proximity of the Procedure Room.

120-volt duplex water proof receptacles should be mounted in each room on the side wall 54 inches above the floor.

Fluorescent type ceiling light fixtures should be recessed with sealed frame, providing 100 foot-candle in each room.

A 3200 foot-candle cool, color corrected surgical light will be installed in Procedure Room.

5.7.5.10 Designated Spaces: Cagewash Room

The Cagewash Room should operate under negative pressure with respect to the corridor. Dirty area shall be under negative pressure with respect to clean area.

A canopy skirt will be installed around the enclosure to minimize the heat and humidity transfer toward the work area.

The equipment vents will be tied into the general exhaust system. Stainless steel up to the point where it is diluted and aluminum to the tie in at the general exhaust system.

Recommended design temperature for cagewash clean and dirty areas is 78 F.

Supply air should be provided by constant volume terminal devices. The temperature should be controlled by a room thermostat placed inside the clean area.

Ceiling supply diffusers should be stainless steel, sealed and gasketed around joints, properly located to move air through the processing area toward the heat producing equipment.

The following services should be provided:

- Cold water at 35...50 psig.
- Hot water at 180⁰F and minimum 35 psig.
- 50...80 psig steam and condensate return.
- Purified water at min 30 psig.
- Min 80 psig compressed air.
- Exhaust air connection.
- 208V, 40 Amp, or 460V, 18 Amp, 3 phase, 60 Hz and 120V, 60 Hz, 1 phase electrical services.

Sanitary waste should be cast iron. A trench drain may be considered in dirty area. The equipment should incorporate an acid neutralization system.

Lighting in both clean and dirty spaces will be fluorescent type provided by ceiling mounted vapor sealed fixtures at a light intensity of 70 foot-candle in the working areas.

5.7.5.11 Designated Spaces: Food and Bedding Storage

The Food and Bedding Storage area should be separately supplied with fresh, non recirculated air at a minimum rate of four changes per hour.

The rooms should be negative pressurized with respect to the corridor. Recommended temperature is 68⁰F to 75⁰F

Stainless steel supply air inlets and exhaust air outlets located in the ceiling should be sealed and gasketed around joints. Ductwork should not be exposed.

Fluorescent lighting intensity will be 70 foot-candle on the floor.

5.7.6 Biosafety

5.7.6.1 Biosafety Levels

Biosafety Barriers

Primary and secondary biological barriers should be used to reduce or eliminate exposure of laboratory environment and the outside environment to potentially hazardous agents. Primary Barriers protect the personnel and the laboratory environment from exposure to infectious agents. Only laboratory equipment is discussed in this biosafety level analysis. Secondary Barriers represent facility design criteria providing protection for persons working inside and outside of the laboratory within the facility and for persons and animals in the outside environment from infectious agents which may be accidentally released from the laboratory. The combinations of primary and secondary barriers will be described for Biosafety Levels Two, Three and Four.

In all instances, the U.S. Department of Health and Human Services Publication number (CDC) 93-8395 "Biosafety in Microbiological and Biomedical Laboratories", 4th edition, May 1999, shall prevail in specifying and defining safety equipment, primary barriers, and architectural or laboratory facility secondary barriers.

Biosafety Level 2

Biosafety Level Two is suitable for work involving agents of moderate potential hazard.

Primary Barriers

Biological safety cabinets, Class II, are required for procedures with a potential for creating infectious aerosols or splashes and those where high concentration or large volumes of infectious agents are used.

Secondary Barriers

Laboratory sink for handwashing.

Autoclave or other decontamination methods should be available.

Bench tops impervious to water and resistant to acids, alkalis, organic solvents and moderate heat.

Sturdy laboratory furniture, with easily cleaned surfaces.

An eyewash facility should be readily available.

The HVAC criteria includes:

100% outside air system.

6 to 12 changes per hour with 4 AC/H unoccupied.

Directional air flow into the laboratory rooms.

Biological Safety Cabinets

The biological safety cabinets should be tested and certified at 12-month intervals. A comparison table of existing types of biological safety cabinets is presented.

TABLE 4.3
BIOLOGICAL SAFETY CABINETS FEATURES AND APPLICATIONS

Type	Min Face Velocity FPM	Airflow Pattern	Radionuclides/ Toxic Chemicals	Biosafety Level	Product Protection
Class 1 * Open Front	75	In at front; out rear and top through HEPA filter	NO	2,3	NO
Class II Type A	75	70% recirculated through HEPA; exhaust through HEPA	NO	2,3	YES
Type B1	100	30% recirculated through HEPA; exhaust via HEPA and hard-ducted	YES (Low levels/ Volatility)	2,3	YES
Type B2	100	No recirculation; total exhaust via HEPA and hard-ducted	YES	2,3	YES
Type B3	100	Same as IIA, but plan under negative pressure to room and exhaust air is ducted (hard or thimble)	YES	2,3	YES
Class III	N/A	Supply air inlets and exhaust through 2 HEPA filters	YES	3,4	YES

* Glove panels may be added and will increase the face velocity to 150 FPM.

5.7.7 Clean Rooms

REQUIREMENTS

Clean spaces are classified according to Federal Standard 209E. Air cleanliness is defined by the number of airborne particles 0.5 µm and larger per cubic foot of air. FS209E also defines the concentration limits of larger and smaller particles in air such as:

- Class 10: – Maximum 350 particles of 0.1µm and no more than 75 particle of 0.2 µm and 10 particles of 0.5 µm per cubic foot.
- Class 100: – Maximum 750 particles of 0.2µm and no more than 100 particles of 0.5 µm per cubic foot.
- Class 1000 – Maximum 1,000 particles of 0.5 µm and no more than 7 particles of 5 µm per cubic foot.
- Class 10000: – Maximum 10,000 particles of 0.5 µm and no more than 70 particles of 5 µm per cubic foot.
- Class 100000 – Maximum 10,000 particles of 0.5 µm and no more than 700 particles of 5 µm per cubic foot.

Large volumes of air are circulated within the clean spaces to dilute the air to required limits. Complexity and cost increase for more stringent conditions required by higher quality classes. The operating cost also reflects high energy consumption necessary to treat and move large volumes of air.

Division 5: Pre-Design Concept

TABLE 1 Airflow requirements for clean room

Class	Air Flow Direction	Air Flow per SF of Floor	Air Changes Per Hour
100,000	Mixed	5-8	5-40
10,000	Mixed	9-15	60-90
1,000	Mixed	20-40	150-240
100	Unidirectional/Mixed	40-80	240-480
10	Unidirectional	50-90	300-540
1	Unidirectional	60-90	360-540

Other factors influencing the cost are:

- Cleaning procedures.
- Filter replacement.
- Restrictions in personnel operation and activity. Access restrictions.
- Special suites, gowning and hats.

Generally air provided to clean spaces will be recirculated, with a surplus of make-up air in order to keep the clean space under positive pressure, and to compensate the exhaust air. Where chemical fume hoods are used in the space, exhausting will be required.

High quality air (low class number) is not necessarily the best environment to work within. The optimum way of reducing cost and providing a high quality environment for the product is a cleaner space in a clean environment such as:

Class 100 workstations, within Class 10,000 clean rooms. In this combination of clean zones, the external sources of contamination are reduced by room HEPA filtration, and the internal sources, generated by processes and operations, are taking care of by additional HEPA filtration at workstations.

TEMPERATURE

Air ambient temperature of $72^{\circ}\text{F} \pm 2^{\circ}\text{F}$ is common in clean rooms. Higher or lower values can also be specified depending on type of activity and personnel wearing. Process related considerations may require as low as $\pm 0.1^{\circ}\text{F}$ tolerances of air temperature. Temperature fluctuations such as $\pm 0.2^{\circ}\text{F}$ over half hour must be specified to define the desired control parameters.

AIR HUMIDITY

Personnel considerations require a relative humidity of 50 +/- 10% . Process requirements may impose other level. Humidity lower than 35% can cause electrostatic effects and relative humidity above 50% can augment oxidation and corrosion. Relative humidity is more difficult to regulate than temperature. Reducing the relative humidity as low as 40% is possible with standard cooling method. Dehumidification below this level require desiccating equipment which is expensive. Fluctuation ranges below $\pm 2\%$ are difficult to achieve and maintain and are very expensive.

Division 5: Pre-Design Concept

ROOM PRESSURIZATION

Clean rooms should maintain a positive pressure relative to surrounding areas. A difference of pressure between a clean room and ambient air of 0.05 in of water (in w.c.) is generally sufficient to eliminate the particulate migration. Cleanest areas have the highest positive pressure. Gowning rooms and ante-rooms are usually one class above the class of served spaces. Air locks should be used to maintain the integrity of controlled spaces during entry and exit of the room.

NOISE

Noise control methods include the acoustically lined enclosures used to quiet the noisy equipment. Silencers may be used in air distribution systems within the materials and space constraints. Duct liners should be avoided.

VIBRATION

Excessive vibration can be caused by activities inside or outside the building. Vibration affecting the products or processes must be minimized or eliminated. Vibration control criteria described under VIBRATION/STRUCTURAL CONSIDERATIONS section should apply.

LIGHTING

A level of 100 foot-candles at work surfaces can satisfy close assembly work and should be considered as a higher limit of lighting. Adjustable lighting is recommended.

Light fixtures should be compatible with the cleanliness requirements of the clean room.

LOCATION

The clean room location within the facility has a product quality and cost impact. Clean rooms should be isolated yet accessible to product flow. Clean rooms should be treated as distinctive areas requiring special personnel protocol. The process flow in and out of the clean space, should be analyzed and defined before the layout. Flexibility should be considered.

5.7.8 Purified Water Systems

A Central Purified Water System will be designed to satisfy the present and future laboratory requirements. Initial cost, operating cost, environmental consideration, minimization of chemical use, reliability, and constructability will be considered.

The level of water purity, defined by regulatory agencies as “Type”, will be selected based on laboratory users requirements. The minimum water specifications for reagent types of water are shown in Table 1.

Table 1

REAGENT WATER SPECIFICATIONS

	CAP Type College of American Pathologists			NCCLS Type Nat. Committee for Clinical Lab. Standards			ASTM Type American Society of Testing and Materials			
	I	II	III	I	II	III	I	II	III	IV
Specific Resistance (megohms.cm)	10	2	0.1	10	1	0.1	16.6	1	1	0.2
Silicate (mg/l)	0.05	0.1	0.1	0.05	0.1	0.1	-	-	-	-
pH	-	-	5 to 8	-	-	5 to 8	-	-	6.2 to 7.5	5 to 8
Bacterial Growth (cfu/ml)	10	10,000	-	10	1,000	-	-	-	-	-
Heavy Metals (mg/l)	0.01	0.01	0.01	-	-	-	-	-	-	-
Carbon Dioxide (mg/l)	3	3	3	-	-	-	-	-	-	-
Ammonia (mg/l)	0.1	0.1	0.1	-	-	-	-	-	-	-
Sodium (mg/l)	0.1	0.1	0.1	-	-	-	-	-	-	-
Particulate Matter (micron)	0.2*	-	-	0.2*	-	-	-	-	-	-

cfu/ml - colony forming units per milliliter.

* 0.2 micron = Less than 500 particles of this size, or smaller, per liter.

Type I water

The most comprehensive requirements for Type I water are specified by CAP. NCCLS specifications match CAP values, but ASTM imposes the highest specific resistance. When both specifications need to be met water will be Type I CAP/ASTM.

Type I water is used in critical laboratory applications such as:
Inorganic Analysis

- ICP - Inductively Coupled Plasma Spectrometry
- IC - Ion Chromatography
- AA - Atomic Absorption Spectro-Photometry
- EP - Electrophoretic Procedures

Organic Analysis

IC	-	Liquid Chromatography
HPLC	-	High performance Liquid Chromatography- Higher restrictions as “organic free” may be imposed.
GC	-	Gas Chromatography
MS	-	Mass Spectroscopy

Biological Applications

Fermentation Systems
In Vitro/In Vivo Fertilization
General Microbiology
Recombinant DNA
Tissue Culture
Immunological Applications

Type II water

Purified water which meets the requirements of most routine clinical laboratory methods in chemistry, immunology, hematology, etc. It is the type of water used in reagent preparation and glassware rinsing. When lower bacterial growth is required the water will be specified as Type II NCCLS.

Type III water

General laboratory grade water. Most qualitative procedures, glassware washing, preliminary rinsing. Final rinsing water should match intended glasswasher use.

5.7.8.1 Water Purification Methods

The basic methods used for water purification are:

Reverse osmosis, producing RO water.
Distillation, producing distilled water.
Deionization, producing deionized water.

A combination of these methods and additional purification processes is necessary to meet levels required by Type I water.

Removal effectiveness of water contaminants by each available water purification technology is shown in Table 2.

Table 2

EFFECTIVENESS OF WATER PURIFICATION METHODS	Reverse Osmosis	Distillation	Deionization	Screen Filtration	Depth Filtration	Ultrafiltration	Adsorption	UV Oxidation
Dissolved Ionized Solids	G	E/G	E	P	P	P	P	P
Dissolved Ionized Gases	P	P	E	P	P	P	P	P
Dissolved Organics	G	G	P	P	P	G	E	G
Particulates	E	E	P	E	E	E	P	P
Bacteria	E	E	P	E	P	E	P	G
Pyrogens	E	E	P	P	P	E	P	P
E= Excellent G= Good P= Poor								

Division 5: Pre-Design Concept

Cost and operational criteria shown in Table 3 should also be considered in selection of purified water system.

Table 3

Process	Advantages	Disadvantages
Reverse Osmosis	minimal maintenance required	moderately high expendable costs limited membrane regeneration
Deionization	regenerable relatively inexpensive to operate	deionization beds generate resin particles and culture bacteria
Microporous Screen & Depth Filtration	minimal maintenance	not regenerable potentially high expendable costs
Ultrafiltration	highest quality water at lowest energy regenerable	
Adsorption	long life capacity	carbon fines downstream of filter removal of chlorine may lead to bacterial growth
UV Sterilization	can produce near total elimination of trace organics in pure water	limited sterilization capability by radiation intensity, contact time and flowrate

5.7.8.2 System Design

Reverse osmosis, RO, water will be provided to the building and stored in a storage tank with highly retentive hydrophobic vent filter or inert gas or nitrogen blanket. The tank content will be recirculated in the building distribution loop through DI water unit.

DEIONIZED WATER UNIT will remove the remaining ionic impurities downstream of RO unit. Continuous electrical regeneration of the DI resin is recommended to eliminate the needs for chemical regeneration, producing continuous deionization on CDI.

High purity water of minimum 15 megaohm-cm should be provided out of CDI unit by this arrangement.

Additional equipment can be included such as:

BIOCIDE INJECTION upstream of softeners, by a metering device for periodical microbial control in the RO tank.
SODIUM METABISULFITE ($\text{Na}_2\text{S}_2\text{O}_5$) injection via a metering device for chlorine removal prior to 1.0 micron filtration. An activated carbon filter can be used for this purpose at a higher operating cost.

ULTRAVIOLET FILTRATION located downstream of CDI unit will further eliminate the trace organics by a 254 nanometer UV radiation.

A final 0.2 micron FINAL FILTRATION can provide final microbial control.

A CHILLED WATER HEAT EXCHANGER can be installed on the distribution piping system to provide temperature control at 62°-72°F with the view of limiting microbial growth.

Division 5: Pre-Design Concept

SANITIZING EQUIPMENT is mandatory in purified water systems in order to control microbiological contamination.

Ozone batch sanitization will be used.

A logic controller will be used to control, monitor and record major parameters. As a minimum, water quality and water flow rates should be connected to an alarm system.

5.7.8.3 Piping Distribution System

The building distribution system should be designed as a continuous loop without dead legs. The system will be run to each point of use. Connections to the faucets should be limited to maximum 6 pipe diameters, but recirculation faucets are preferred.

Velocities through distribution system should be 5 to 7 feet per second.

Selection of piping materials for purified water systems is critical, involving water quality and cost criteria.

PVDF - Polivinyldene Fluoride, with thermal welded connections, is recommended for piping, valves and fittings of highest water purity (Type I).

PP - Unpigmented Polypropylene, fused socket weld piping, valves and fittings are recommended as a basic material for purified water systems. Pigmented Polypropylene may be subjected to ultraviolet degradation promoted by pigments and also leaching of pigments into the water.

5.8 Architectural Systems

5.8.1 Access/Circulation

The entry routes to the Cowley Hall Science Facility and the interior circulation system will be barrier-free accessible, functionally organized to promote efficient wayfinding, and distinctively designed. The primary building entrance(s) will be strategically positioned to relate to the primary student routes. The site provides opportunities for multiple building entrances from different sides of the building. The entrance(s) will be protected from the elements and have vestibules. The main entrance could be positioned along the west side of the building at three different locations. An entrance at the northwest corner will address pedestrian traffic to and from Wimberly Hall to the northwest, Murphy Library to the west, and the future Student Center to the north. A centrally located entrance along the west side of the building would have a direct access to the west facing courtyard and campus mall. An entrance located at the southwest will be used by pedestrians between Cowley Hall and Centennial Hall.

The main entrance will open into a public lobby space that serves as a general reception, route-finding, donor recognition, and waiting area. Every resourceful way to economically distinguish this space (i.e., natural light, openness, materials, colors, etc.) will need to be considered. The horizontal and vertical circulation routing should originate from the lobby and distribute people to the programmed rooms of the building in a convenient, safe, and memorable way. Integration of effective wayfinding devices, such as natural light, clever signage, and simple routing, are highly desirable. Careful consideration should be given to high-use, large capacity rooms to minimize circulation disturbance to nearby quiet rooms.

5.8.2 Image

The Cowley Hall Science Facility is located in a highly visible location on campus. In addition, due to its prominent location on campus, the building will need to be treated as one that will be seen and experienced from multiple sides. Consequently, the design of the exterior of the building will be a critical task.

The Cowley Hall Science Facility should respect the context of the overall campus physical organization and should also respect the context created by nearby Wittich Hall and Centennial Hall. The new building, while reflecting current design thinking, will need to quietly blend in with the existing context, in deference to existing iconic buildings and open spaces. Efforts should be made to adhere to the Architectural Guidelines that are in place within the Campus Master Plan.

The building must promote the prominence of a cutting-edge science facility, yet still fit into the distinctive UW-La Crosse campus environment. Each of these characteristics will contribute individually and collectively to the overall image as follows:

5.8.3 Site

The Cowley Hall Science Building is currently located at the geographic and academic center of campus. It will provide a firm anchor for the main academic core of the campus and will shape the northeast corner of the future Campus Mall. The building site is surrounded by existing academic buildings with Murphy Library to the west, Morris Hall to the south, Centennial Hall to the southeast, and Wimberly Hall to the northeast. A future Student Union will be located directly to the north. In addition, the Hoeschler Clock Tower, which is the main outdoor gathering place for the campus community, is located at the southwest corner of the site.

The project site is centrally located and because it will be utilized by a large number of students, faculty and staff, special attention will need to be given to the development of the site and its amenities including; circulation of pedestrians, bicycles and service vehicles, as well as landscaping, exterior signage and the creation of gathering areas.

5.8.4 Character

The challenge of new architecture in a campus setting is to contribute to the visual unity of the campus while expressing its own design character. This facility should invoke the inquisitive spirit and resourcefulness of its inhabitants, without being trendy or obvious. The building should exude an inviting, memorable, and collegiate air that captivates a visitor and enriches the users.

5.8.5 Scale

The building's location, height, and massing work individually and in conjunction with one another to influence the viewer's experience of its scale. The positioning of the building on the site to create favorable outdoor spaces, welcoming entrances, and easy wayfinding is of utmost importance. The height of the facility relative to adjacent buildings is a critical factor in maintaining a homogenous character to the campus and maximizing views of, and from, the building. The mass of the facility is

Division 5: Pre-Design Concept

an important ingredient to help visually define the building function externally and its relationship to adjacent structures. Explore ways to penetrate the massing, to make it more transparent in certain areas to help increase the feeling of involvement for the external viewer. The two opposing forces of closedness (opacity) and openness (transparency) can be harnessed effectively to promote a sense of direction, orientation, and assist both physically and mentally in creating a memorable environment.

5.8.6 Materials

Considering that the earliest buildings on the UW-La Crosse campus have been in use for nearly a century, the durability of materials is clearly a major material influence. Brick has been the primary building material utilized throughout the campus and should be the core material ingredient. Contributing subordinate material selections, i.e., stone, glass, metal, should be in keeping with the established campus palate of colors, textures, and finishes. Introduction of new materials requires sensitive design scrutiny and detailing, yet can be used effectively to distinguish the facility.

5.8.7 Interior Spaces

The facility will include the following space types:

- Offices and Office Support
- General Access Classrooms
- Teaching Laboratories
- Computer Laboratories
- Collaborative Learning Spaces
- Animal Facility
- Conference Rooms
- Building Support

5.8.8 Interior Partitions

- Walls should typically be constructed of gypsum wall board on metal studs with a painted surface. The gypsum wall board should be dent and abrasion resistant at areas of heavy use (corridors and classrooms). Wood chair rail trim to be provided in rooms with movable chairs.
- Sound attenuation should be used wherever sound isolation is required. Refer to Section 5.8.16 for Acoustical Design Considerations for minimum Sound Transmission Class (STC) ratings.
- Classroom and office walls should extend from top of slab to underside of structure and will be acoustically sealed at the top and bottom. Provide two layers of 5/8" drywall on each side of classroom and corridor walls with insulation in the cavity. Drywall seams will be staggered and each layer taped and mudded individually.
- Painted unit masonry may be used in spaces that require additional durability.

5.8.9 Doors

- Interior doors should be 1-3/4" thick solid core natural wood finish doors in painted steel frames, at least 3'-0" wide by 7'-0" high, or wider if required for egress by code or higher if required for equipment movement.
- Vision panels and/or sidelites to corridors should typically be provided where feasible. Refer to Division of State Facilities Accessibility Guidelines for height requirements above finished floor.
- At code-required fire-rated locations, doors and frames should be fire-rated assemblies.
- Door hardware should be code compliant, heavy-duty type, lever style, with mortise locksets. Locksets must be compatible with existing campus locks. All doors should be lockable with a "Classroom" function, i.e., egress is always possible without a key.
- Entrance doors and frames should be anodized, thermally broken aluminum with insulated glass and should be 3'-6" wide minimum or wider if required for egress by code. All entrances should incorporate automatic operators with push button access.
- Reference Appendix A: Room Data Sheets for lab spaces.

5.8.10 Windows

- Windows should be maximized at exterior walls where appropriate while also minimizing direct sunlight and glare on work surfaces.
- Windows at exterior walls should be provided with clutch-driven roller shades.
- Interior windows should be incorporated where appropriate for “borrowed” natural light.
- Exterior windows should be anodized, thermally broken aluminum frames with high performance insulated glass.
- Windows should be provided in as many occupied spaces as possible.
- Natural Light Prioritization:
 1. Full-Time Faculty Offices
 2. Classrooms
 3. Teaching Labs
 4. Resource Areas
 5. Reception Areas
 6. Collaborative Learning Spaces
 7. Conference rooms
 8. Workrooms
 9. Storage

5.8.11 Ceilings

- Suspended grid tile ceilings should be provided where required for acoustics and cleanliness. Rooms without such requirements will have no ceilings and can remain open to the structure above.
- Classrooms should have 10'-8" minimum ceiling heights; other areas many have lower ceiling heights. (min. 7'-6" by code)
- Pendant mounted light fixtures may be suspended below the 10'-0" ceiling. Careful consideration and study should be done by the A/E team to determine the appropriate ceiling height as it relates to window height and daylight penetration into the space. A/E must also consider projection screen height and usable marker board space as it relates to mechanical space above the ceiling.
- Acoustic tiles should be used in most suspended grid ceilings. Wood and metal panel ceilings may also be used, but in limited quantities to control future maintenance needs.
- Laboratory spaces should have acoustical tile. Refer to Appendix A: Room Data Sheets for finish description of each laboratory space.

5.8.12 Flooring

- Lobbies, corridors, and stairs should have the highest quality floor finishes based on cost, maintenance, and durability. Acceptable materials include terrazzo, terrazzo tile, and porcelain tile.
- Classrooms should have anti-static, high traffic, commercial grade carpet tile.
- Ceramic/Porcelain tile and base will be provided in restrooms.
- Sealed concrete should be provided in mechanical spaces with waterproofing membrane finish at penthouse floor.
- Conference rooms and office suites should have anti-static, high traffic, commercial grade carpet tile.
- Laboratory spaces should have epoxy, welded seam sheet vinyl, or chemical resistant VCT. Refer to Appendix A: Room Data Sheets for finish description of each laboratory space.

5.8.13 Finishes

- Walls should typically be painted. UW-La Crosse prefers materials that are easy to maintain and that are mold resistant. UW-La Crosse also prefers paint instead of wall covering.
- Protective chair rails should be installed for wall protection in any classroom with a flat floor as well as any conference room with movable furniture.

5.8.14 Technology Levels

- Technology levels for individual classrooms are identified in their respective Room Data Sheets.
- Refer to Division 4, Section 4.7 for listing of provided equipment.

5.8.15 Casework

- Casework should be finished with plastic laminate.
- Floor mounted casework should be provided at room perimeters of classrooms where required.
- Movable storage cabinets shall be provided in departmental workrooms and storage areas.
- Grommets should be provided for wire management whenever possible.
- Laboratory casework shall be wood cabinets, metal hoods, and epoxy resin benchtops.

5.8.16 Acoustical Design Considerations

- The following guidelines are based on ANSI/ASA S12.60-2002 American National Standard Acoustical Performance Criteria, Design Requirements, and Guidelines for Schools.
 - Walls between classrooms and corridors should have a minimum STC rating of 45.
 - Walls between classrooms should have a minimum STC rating of 50.
 - Walls between classrooms and public use rooms should have a minimum STC rating of 53.
 - Walls between classrooms and mechanical equipment rooms should have a minimum STC rating of 60.
 - Diffusers should have a Noise Criteria (NC) rating of NC 18 or less.
 - Airflow velocities in duct mains shall be 1500 ft/min max and branch ducts shall not exceed 800 ft/min.
 - VAV boxes and fan-powered boxes should be located outside of classrooms if possible.
- The design team must evaluate the acoustics in each size of classroom and provide acoustically absorbent finishes wherever required.
- Ceiling tiles with a .65 or greater Noise Reduction Coefficient (NRC) should be used.

5.8.17 Restrooms

- Restrooms should have tile floors and walls.
- Restroom partitions should be solid polymer.
- Restroom accessories provided by UW-La Crosse include: toilet paper, paper towel, feminine hygiene, and soap dispensers and trash receptacles.
- Restroom lavatories should be constructed of plastic laminate casework with a solid surface countertop and stainless steel under-mounted sinks.
- Ceramic/porcelain tile should be installed on toilet room walls. Walls behind and adjacent to plumbing fixtures should have a tile wainscot a minimum height equal to the height of the toilet partitions.

5.8.18 Signage

- Provide interior room signage, directories, and wayfinding graphics throughout the building.
- Digital signage should be considered in main corridors and lobby spaces.
- Provide exterior building signage at the west and east entrances.

5.9 Structural Systems

Based on the structural performance characteristics required for the laboratories, a structural concrete frame system is recommended. Proposed system is a one way concrete joist and beam system supported by concrete columns. Lateral bracing will be by concrete shear walls. A column grid of 21 feet by 33 feet would accommodate the proposed module and be economical spans for this system. The floor vibration characteristics can be designed to limit the vibratory accelerations due to walking and is capable of meeting the VC-A criterion recommended in the laboratory systems which is a maximum vibratory velocity of 2,000 micro-inch per second.

Based on previous soil borings and geotechnical reports for adjacent buildings, a foundation system of conventional spread footings can be used to support the building.

5.9.1 Laboratory Vibration/Structural Considerations

The nature of science teaching and research activity being conducted, requires structural dynamics consideration.

Footfall-induced vibrations on above-grade floors, should be reduced by:

- Confining heavily traveled areas to regions near column lines,
- Placing sensitive equipment near columns,
- Placing the equipment away from heavily traveled areas,
- Minimizing the length of spans.

Increasing the stiffness of the floor slab alleviates vibration. Providing a combination of mass and/or depth for above grade slabs increases the stiffness. Cast-in-place concrete has natural characteristics and mass advantages for vibration reduction; a concrete frame structural system is anticipated in this building.

For vibration considerations, laboratory areas should be designed for 125 psf live load. Computer server rooms should be designed for 180 psf of equipment load above other live load factors.

Air handling equipment and ductwork shall be designed to minimize vibration. Supply and exhaust air fans, compressors, pumps, and other noise and vibration producing equipment should be located in mechanical rooms with protective wall construction. Equipment should be isolated from supporting structure with resilient mounts. Vibration isolators should be selected based on floor stiffness, span extension, equipment power and operating speed.

Instruments that are extremely sensitive to vibration (scanning electron microscope or transmission electron microscope, NMR etc) should ideally be located on slab-on-grade construction to minimize transient structure-borne vibration. Provisions of an isolated slab should be analyzed.

Pneumatic and piezoelectric isolations should be used, as required, on specified highly sensitive equipment.

Vibration criteria for areas intended to accommodate sensitive equipment are based on rms Velocity Level as measured in one-third octave bands of frequency over the range of 8-100 Hz. Generic Vibration Criterion (VC) curves have been developed for different types of equipment. The results are shown in Table 1.

Criterion curves VC-A through VC-E are applicable to research facilities. International standards Organization (ISO) criteria for human exposure to vibration are also shown.

It is recommended that the structural floor system be designed to meet the **VC-A** criterion. The design should follow the AISC Guidelines of Design for Sensitive Equipment.

Seismic stabilization of the structure should be addressed. Natural frequency of floor and building structure should be determined in function of the Seismic Zone of construction site. A minimum building natural frequency of 8Hz is recommended for optimum operation of vibration isolating equipment unless seismic, or other criteria may impose a lower frequency.

TABLE 1

**DESIGN CRITERIA FOR SENSITIVE INSTRUMENTATION AND EQUIPMENT
NOT OTHERWISE VIBRATION-ISOLATED**

Criterion Curve	V _{rms} Velocity Level		Detail Size (μm)	Description of Use
	(μin/s)	(dB) Ref:1μin/s		
Workshop (ISO)	32,000	90	N/A	Distinctly felt vibration. Appropriate to workshops and non-sensitive areas.
Office (ISO)	16,000	84	N/A	Felt vibration. Appropriate to offices and non-sensitive areas.
Residential Day (ISO)	8,000	78	75	Barely felt vibration. Sleep areas in most instances. Probably adequate for computer equipment, probe test equipment and low-power microscopes (to 20X).
Op.Theatre (ISO)	4,000	72	25	Vibration not felt. Suitable for sensitive sleeping areas. Suitable in most instances for microscopes to 100X and for other equipment of low sensitivity.
VC-A	2,000	66	8	Adequate in most instances for optical microscopes to 400X, microbalances, optical balances, proximity and projection aligners, etc.
VC-B	1,000	60	3	Optical microscopes to 1000X, inspection and lithography equipment (including steppers) to 3 micron-meter line widths.
VC-C	500	54	1	A good standard for most inspection equipment and lithography to 1 micron micron-meter detail size.
VC-D	250	48	0.3	Suitable in most instances for the most demanding equipment including electron microscopes (TEMs, SEMs, AFMs) and E-Beam systems, operation to the limits of their capacity.
VC-E	125	42	0.1	A difficult criterion to achieve in most instances. Assumed to be adequate for the most demanding of sensitive systems including long path, laser-based, small target systems and other systems.

Detail Size column expresses the minimum width of fabrication details or size of research particles that could be handled at a specific criterion value.

5.10 Fire Protection Systems

5.10.1 Applicable Codes, Guidelines, and Standards

Design and construction codes and standards are listed below.

The codes and standards listed are minimum requirements. Nothing is to prevent the architect, engineer, or consultant from exceeding the applicable requirements. In the case of laboratory related research buildings, the recommendations of the guidelines below and the standards and requirements suggested by the design team will often address issues not sufficiently covered in local building codes.

In all cases the most recent editions of referenced standards apply.

NFPA 13, Installation of Sprinkler Systems

NFPA 14, Installation of Standpipe and Hose Systems

NFPA 24, Installation of Private Fire Service Mains

NFPA 45, Standard on Fire Protection in Laboratories Using Chemicals

NFPA 70, National Electric Code

NFPA 72, National Fire Alarm code

NFPA 101, Life Safety Code

State of Wisconsin, DOA, Division of State Facilities Master Specifications

University of Wisconsin-LaCrosse Design Standards

5.10.2 Water Service

The facility shall be provided with a combined fire protection & domestic water service (6" diameter minimum) installed by the plumbing contractor in Phase 1. The fire protection contractor shall connect to a tee provided by the plumbing contractor.

Current water supply flow test results will be obtained from the campus or the local water utility for design purposes.

An ASSE 1015 Double Check Fire Protection Backflow Prevention Assembly shall be provided by the fire protection contractor to isolate the fire protection systems from the potable water system.

Water for Phase 2 fire suppression will be furnished from Phase 1.

5.10.3 Fire Suppression Systems

Fire suppression systems consist of:

Water pressure was measured near the site in 2007 and reported to be 78 psi which should be sufficient to support an automatic sprinkler system. The building is not considered a high-rise therefore a fire pump installation to support an automatic standpipe system is not required.

Wet pipe automatic sprinkler system.

- All areas of the building will be protected, including electrical rooms (switchgear, transformers, generators, electrical and telecommunications closets, etc.), elevator hoistways and machine rooms, loading docks, stair towers, exterior canopies, and mechanical rooms.
- All systems will be hydraulically calculated with a computer calculation program using the Hazen-Williams method.

Division 5: Pre-Design Concept

- Areas designated as Light Hazard Occupancy will be designed for a minimum sprinkler flow of 0.10 gpm per sq. ft. over the hydraulically most remote 1500 sq. ft.
 - Areas designated as Ordinary Hazard, Group 1 will be designed for a minimum sprinkler flow of 0.15 gpm per sq ft. over the hydraulically most remote 1500 sq. ft.
 - Areas designated as Ordinary Hazard, Group 2 will be designed for a minimum sprinkler flow of 0.20 gpm per sq ft. over the hydraulically most remote 1500 sq. ft.
- Minimum water supply requirements for a hydraulically designed sprinkler system shall be determined by adding the appropriate hose stream demand per NFPA 13 to the total sprinkler water demand.
 - Each floor will be a separate sprinkler zone with floor control valve, supervisory switch, and water flow indicator switch.
 - Materials: The piping for the wet pipe sprinkler system will be black steel. Piping 2" and smaller in size will be Schedule 40 with threaded joints. Piping larger than 2" will be Schedule 10 with welded or roll groove couplings or Schedule 40 with welded, threaded, or cut groove couplings. Unscheduled specialty steel and CPVC plastic piping is not allowed.
 - Flexible sprinkler connectors are allowed.
 - Butterfly valves with geared operator, visual position indicator, and supervisory switch
 - Flow Switches: Vane type water flow indicator switch with adjustable retard.
 - Quick response fusible link or glass bulb sprinklers, UL listed/FM approved. Provide ordinary temperature rated sprinklers except at skylights, adjacent to unit heaters, and adjacent to un-insulated heating piping.
 - The type of sprinkler used in a particular area will be selected by the Engineer of Record and the Architect. Generally, concealed sprinklers will be installed in areas of high visibility and quality of finishes. Semi-recessed sprinklers with chrome heads will be installed in areas with suspended ceilings. Pendent or upright sprinklers will be installed in areas without ceilings.
 - Center-of-tile sprinkler head placement will be specified in all public and occupied spaces. Back-of-house spaces do not require center-of-tile placements. Sidewall sprinklers will be used only when other types cannot be used.

Class 1 manual wet standpipe system

- Class 1 manual wet standpipe system. The standpipe system is required since the highest floor level of the buildings is more than 30' above the lowest level of fire department access.
- Standpipes will be located in each stair tower with 2½" fire department valves/hose connections serving each floor level and on roof. Additional 2½" hose connections may be required by the Fire Department if the most remote portion of a floor is located in excess of 200' of travel distance from a stair tower containing a hose connection.
- Materials: Piping for will be black steel, Schedule 10 with welded or roll groove couplings or Schedule 40 with welded, threaded, or cut groove couplings

Phase 1: One wall mounted four-way fire department inlet connection (FDC) in location subject fire department approval.

Phase 2: One wall mounted four-way fire department inlet connection (FDC) in location subject fire department approval.

5.11 Plumbing Systems

5.11.1 Applicable Codes, Guidelines, and Standards

Design and construction codes and standards are listed below.

The codes and standards listed are minimum requirements. Nothing is to prevent the architect, engineer, or consultants from exceeding the applicable requirements. In the case of laboratory related research buildings, the recommendations of the guidelines below and the standards and requirements suggested by the design team will often address issues not sufficiently covered in local building codes.

In all cases the most recent editions of referenced standards apply.

COMM 81 – 87, Wisconsin Plumbing Code

State of Wisconsin, DOA, Division of State Facilities Master Specifications

University of Wisconsin-LaCrosse Design Standards

NFPA 54, National Fuel Gas Code

NFPA 99, Health Care Facilities

5.11.2 Domestic Water

A combined domestic and fire protection water service, 6" diameter minimum, will be provided in Phase 1. Flow tests will be requested during design to verify adequate flow and available water pressure. Water supply for Phase II will be furnished from Phase 1.

A blind flange will be furnished at the building entrance for the fire protection contractor to connect the combined automatic sprinkler/manual standpipe system.

A water meter with full size bypass for the domestic water system

Domestic hot and cold water will be provided to all plumbing fixtures and any other devices and equipment that require a domestic water supply, including water purification equipment furnished by laboratory consultant.

Maximum pressure of 80 psi

Minimum available pressure at the most remote fixture or piece of equipment of 35 psi

Water distribution piping will be sized for a maximum velocity of 8 fps

5.11.3 Sanitary Drain Waste and Vent

A sanitary drain waste and vent system will be provided for all plumbing fixtures, floor drains, indirect waste receptors, and equipment that require drainage.

Plumbing fixtures and devices will be drained by gravity through conventional drain, waste and vent stacks, sanitary building drains and building sewers to the municipal or university owned sanitary sewer.

5.11.4 Storm Water and Clearwater Drainage

- New roof drainage and clear water waste systems including a under floor storm building drain to 5' beyond foundation wall for connection to the storm building sewer.
- Connect roof drains to building storm drainage system.
- To protect structural elements from excessive water on the roof, there will be either roof scuppers or a secondary (overflow) roof drainage system. When overflow roof drains are used connect independent overflow roof drainage piping to nickel bronze downspout nozzles and discharge through exterior wall to daylight.

Division 5: Pre-Design Concept

- Clearwater waste from air handling units, ice machines, etc will be conveyed by gravity through a separate drain and vent piping system and will connect to the building storm drain.
- A Geotechnical report will be needed for recommendations regarding the need for a sub-soil drainage system. A sub-soil drainage system with perforated piping around the building exterior perimeter should be assumed.

5.11.5 Acid Waste Drainage

A chemical waste and vent system will be provided for all plumbing fixtures, floor drains, indirect waste receptors, and equipment that that receive chemical wastes having a pH level of less than 5.5 or more than 10.

All chemical vent systems shall be separate from all other vent systems and terminate through the roof independently.

Above ground chemical waste and vent pipe and fittings shall be polypropylene, ASTM F1412, flame retardant while high silicon iron Duriron/Novacast or Bonstand shall be used below grade. Pipe and fitting shall be joined using electrical fusion welding. Pipe and fittings shall be joined using mechanical joint couplings.

All chemical wastes shall pass through a neutralizing or dilution basin before discharging to the sanitary building drain or sewer.

See Section 5.11.11 for additional information.

5.11.6 Natural Gas

A piped distribution system will furnish natural gas to all laboratories.

Building Distribution Piping (above grade and to 8" below slab): Black steel pipe, ASTM 53 (Schedule 40), type E or S.

See Section 5.11.11 for additional information.

5.11.7 Plumbing Fixtures

The plumbing fixtures will be furnished in accordance with LEED 2009 to promote water efficiency and reduce the burden upon municipal water supply and wastewater systems.

Water Closets: Wall hung vitreous china HET with manually operated flush valve, 1.28 gpf

Urinals: Wall hung vitreous china HEU with sensor operated flush valve, 0.125 gpf maximum.

Lavatories: Self-rimming or wall hung vitreous china fixtures will be provided in all toilet rooms. Faucets shall be sensor operated. Flow will be restricted to 0.5 gpm maximum.

Wall hung bi-level electric water coolers with inlet water filter.

Sinks: Self-rimming 18 gauge stainless steel sinks. Sink faucets shall have gooseneck spouts. Sinks used solely for hand washing purposes shall have sensor operated faucets. Sinks used for multiple purposes shall have faucets with 4" wrist blade handles. All faucets will be restricted to 1.6 gpm maximum.

Wall boxes with a valved water inlet will be provided at all locations where an ice maker or coffee maker is required.

Mop basins: 36" x 24" x 10" mop service basins, faucet with hose connection vacuum breaker and lever handles, and stainless steel wall guard panels.

Self-draining frost resistant wall hydrants with ¾" hose connections will be provided along the building perimeter with one per each wall face and at maximum of 150' intervals.

Emergency Fixtures: Emergency eyewash and showers with thermostatic mixing valves to deliver 80°F water will be provided per building program.

5.11.8 Laboratory and Animal Facilities Fixtures and Equipment

Division 5: Pre-Design Concept

All specialized laboratory and animal facility fixtures and equipment will be furnished and set in place by the laboratory consultant. All rough-in piping and final connections to the fixtures and equipment will be by the Division 22 contractor.

All hose bibbs, floor drains, cross connection control devices, and similar plumbing specialties will furnished by the Division 22 contractor.

5.11.9 Plumbing Equipment and Specialties

Twin or triplex alternating water softener to condition water going to the water heaters, RO-DI equipment, mixing valves, and any sensor operated faucets

Campus steam will be used for domestic water heating and laboratory/animal water heating. Water heaters shall have double walled heat exchanger.

Circulating pumps will provide hot water temperature maintenance within the domestic hot water piping system(s)

Reduced pressure principle backflow preventers will be furnished in the make-up water lines to all mechanical equipment not furnished with an integral air gap on the water inlet to the equipment and to isolate the industrial water distribution systems from the potable water systems

Air Compressor: Duplex air compressor, with desiccant air dryer, to provide instrument grade compressed air to the laboratories

Vacuum Pump: Duplex vacuum pumps with receiver to provide vacuum for the laboratories.

Sump pump installations at bottom of all elevator hoistways consisting of an 18" diameter x 22" basin with a 30 gpm sump pump. Discharge is to the building storm drainage system.

Storm/clearwater waste sump pump installation to serve floors and area wells that cannot drain by gravity to the storm building drain.

Duplex sewage ejector to serve floors that cannot drain by gravity to the sanitary building drain.

5.11.10 Laboratory Piped Services

Laboratory piped services will be distributed throughout the facility, as required.

The criteria for each service listed below should be considered for these systems:

Industrial Cold Water and Hot Water (IHW, ICW)

An industrial water system will be distributed through each floor of the building. A central backflow prevention device will be provided. Industrial grade water will be provided at laboratory sinks, cupsinks and hoods. All fixtures utilizing industrial water shall have a sign stating "NON-POTABLE WATER". Discuss need for and industrial water system in the DD phase as many lab users prefer the potable water system with vacuum breakers.

Potable Cold Water and Hot Water (CW, HW)

A potable water system will be distributed through each floor of the building. A central backflow prevention device will be provided on cold water supply, to protect site mains from backflow from the building. Potable water will be supplied at drench hoses and safety shower/emergency eyewash fixtures. Vacuum breakers shall be provided at each outlet to meet code requirements. In accordance with ANSI Z358.1-1998, delivered flushing water to safety shower/emergency eyewash fixtures shall be tepid; a temperature of 80° F is recommended.

Division 5: Pre-Design Concept

Purified Water (RO, DI)

A Central Purified Water System will be designed to satisfy the present and future laboratory requirements. Initial cost, operating cost, environmental consideration, minimization of chemical use, reliability, and constructability will be considered. Type II CAP or ASTM water resulting from reverse osmosis (RO) and deionization (DI) will meet the requirements of most routine laboratory methods in chemistry as well as in reagent preparation and glassware rinsing. When lower bacterial growth is required the water will be specified as Type II NCCLS. More stringent water purity requirements Type I CAP or ASTM will be provided by local units fed from the central system. The purified water specifications are further detailed in a separate section.

Compressed Air (CA) and Laboratory Compressed Air (LA)

Oil-free instrument grade compressed air (CA) of 100 psig, dried to 2.1 grams of water per pound of dry air (37°F pressure dew-point), will be supplied to the main riser. Valved and capped take-offs at each floor will be provided for future 100 psig needs. A pressure reducing valve will regulate the pressure in each floor distribution loop, providing 15 psig at laboratory services.

Laboratories will be provided with a centralized vacuum system. The system should include duplex vacuum pumps, storage tank(s), controls, and distribution piping providing minimum 21 inch Hg negative pressure at the vacuum service.

Laboratory Vacuum (LA)

Laboratories will be provided with a centralized vacuum system. The system should include duplex vacuum pumps, storage tank(s), controls, and distribution piping providing minimum 21 inch Hg negative pressure at the vacuum service.

Laboratory Vacuum Pump Discharge

The local vacuum pumps should discharge into laboratory exhaust system. The oil ring vacuum pumps should be provided with an oil collector at the lowest end of the vertical pipe. When the discharge from multiple pumps is manifolded, a check valve should be provided on each individual discharge. Local vacuum pumps required by specific equipment shall be supplied by the equipment user.

Laboratory Gas (LG)

Natural gas will be supplied at low pressure, usually 7 in. of water.

Laboratory Gases (CO₂), (N₂), (O₂), (H₂), (He), (Ar)

Specialty gases will be provided by local gas cylinder stations located in designated closets adjacent to laboratories. A generic interchangeable piping distribution system will be considered for non-toxic, non-flammable gases.

Steam and Condensate (MPS), (CD)

All laboratories with steam consumption equipment will be provided with medium pressure steam and condensate return lines. Steam pressure will be minimum 80 psig at the point of use. Condensate return will be at atmospheric pressure.

Equipment Cooling Water (CEWS, CEWR)

A limited building system of recirculating cooling water is recommended for laboratory equipment or instruments cooling. Cooling water of approximately 65°F will be prepared in a plate and frame heat exchanger using chilled water or glycol-water solution as a cooling agent. Cooling of Cold Room condensers should be evaluated in the preliminary design phase as to being cooling water or air cooled. DSF prefers water cooling.

Recirculated Cooling Tower Water (CTWS, CTWR)

Cooling tower water will be used for the needs of water cooled refrigerating units on cold and warm rooms.

Laboratory Waste System (LW)

The laboratories will be provided with an acid-resistant drainage system connected to the sanitary sewer outside the building perimeter after dilution levels are achieved. The sinks, cupsinks and piping materials to the floor drops should be of acid

Division 5: Pre-Design Concept

resistant materials. Below grade acid-resistant pipes will accommodate minor quantities of acids and solvents in case of an accidental spill. Floor drains will be equipped with automatic trap primers.

The following materials are recommended for piped services:

IHW, ICW, HW, CW, CEWS, CEWR: Copper tube, Type L, with wrought copper fittings and brazed or soldered joints.

LA, A100: Cleaned and capped type L copper-brazed, nitrogen purge, or ABS Air-line polymeric blend piping with solvent welding joints.

LV: Copper tube, type L, with solder joints, or PVC with solvent cement joints or ABS Air-line polymeric blend piping with solvent welding joints.

Laboratory Vacuum Pump Discharge: Black steel, Copper, PVC or other materials compatible with composition of exhausted chemicals.

RO/DI water: Unpigmented polypropylene (PP) pipe, valves and fittings with electrofusion joints.

High purity water: Unpigmented polypropylene (PP) piping with electrofusion joints. Polyvinylidene fluoride (PVDF) with solvent welded or threaded joints will also be considered.

Laboratory gases: Type L copper pipe, ACR grade, purged and brazed will be the standard material for CO₂, N₂, He, Ar. Stainless steel will be used for H₂ and ultra high purity gases piping.

LG: Black steel with welded and threaded wrought iron fittings as required.

Steam, condensate: Black steel.

LW, LWV: Laboratory acid waste and vent: Mechanical joint polypropylene above grade. High silicon iron Duriron/Novacast or Bonstand below grade

Storm and sanitary waste: Heavy duty cast iron. No hub.

All piping components subject to sweating, heat loss or freezing will be insulated with appropriate thickness of insulation and fire-retardant jacket.

Each laboratory should have easy access to all services and should be isolated to allow any laboratory to be shut down for repair or emergencies without affecting other laboratories.

A complete set of laboratory piped services should be stubbed out for each laboratory even though all services may not be initially required in all laboratories. This will increase flexibility and minimize remodel and retrofit costs as laboratory uses change. Each laboratory unit will have separate shut-off valves located in a consistent, accessible manner for emergency shutoff.

5.12 Mechanical Systems

5.12.1 Applicable Codes, Guidelines, and Standards

Design and construction codes and standards are listed below.

The codes and standards listed are minimum requirements. Nothing is to prevent the architect, engineer, or consultant from exceeding the applicable requirements. In the case of laboratory related research buildings, the recommendations of the guidelines below and the standards and requirements suggested by the design team will often address issues not sufficiently covered in local building codes.

In all cases the most recent editions of referenced standards apply.

Wisconsin Enrolled Commercial Building Code

Laboratory Design Guidelines

ACGIH Industrial Ventilation - A Manual of Recommended Practice (the latest edition)

ANSI/AIHA Z9.5 2003 - Laboratory Ventilation Standard

OSHA 29 CFR Part 1910 - Occupational Exposures to Hazardous Chemicals in Laboratories

Occupational Safety and Health Administration (OSHA)

ASHRAE Standard 62-2001 Ventilation for Acceptable Indoor Air Quality

Guide for the Care and Use of Laboratory Animals - 1996 (National Research Council)

DSF - HVAC Design Guidelines

State of Wisconsin, DOA, Division of State Facilities Master Specifications

University of Wisconsin-LaCrosse Design Standards

Issues not addressed by current Wisconsin Enrolled Commercial Building Code will be designed in accordance with the following:

National Fire Protection Association (NFPA) guidelines and standards including the following:

- NFPA 30 - Flammable and Combustible Liquids Code.
- NFPA 45 - Fire Protection for Laboratories Using Chemicals
- NFPA 90A - Standard for the Installation of Air Conditioning and Ventilating Systems.
- NFPA 101 - Life Safety Code

5.12.2 HVAC Systems Analysis

Multiple system options will be required to be studied through computer modeling at the preliminary design phase. This includes heat recovery chillers and a central geothermal water to water heat pump system for providing chilled water and hot water. DFS design guidelines are to be followed for these studies.

5.12.3 Chilled Water System

Mechanical cooling will be provided from the campus chilled water system, utilizing the available capacity from the chillers located in the Chilled Water Plant and from a future plant yet to be determined. A Masterplan prepared by UW Systems indicates that a new chilled water plant must be in place at the time that Cowley Hall Phase 1 and the Student Union are complete in the year 2015.

Division 5: Pre-Design Concept

Estimated 12" Chilled water supply and return mains will need to be extended from the existing 18" mains at the southwest corner of Wimberly Hall, based on rough load calculations. This will need to be confirmed by the design engineer. These mains will also serve the future Student Union that will be located just north of Cowley Hall. Estimated 10" chilled water branches will enter Cowley Hall on the north side of the building. Phase two is anticipated to use the existing chilled water service currently serving Cowley Hall.

A secondary chilled water pump will not likely be required due to the building's close proximity to the chiller plant.

The central air-handling equipment will be furnished with chilled water coils. The chilled water piping will remain charged (full) throughout the year; however, coils will be drained and dried via connection to the high pressure side of air handling system. It is anticipated that the proposed phase one building will have an estimated 1000 ton cooling load and the proposed phase two building is anticipated to have a 685 ton cooling load.

5.12.4 Steam and Hot Water Heating Systems

High pressure steam from the campus boiler plant will be utilized for building heat and domestic water heating for this facility. A 6" steam service is anticipated for the phase one building and will enter the building in a mechanical room on the lower level from the north. A new 6" main from existing manhole #3 will serve both Cowley Hall (Phase 1) and the future Student Union. The existing 4" high pressure steam service will be utilized to serve the phase two building. A pressure reducing station will provide low pressure steam for use in each building. Steam-to-hot water shell and tube heat exchangers will then heat both building heating water and domestic hot water.

The hot water pumping systems for each building phase will utilize variable volume pumping. Two circulating pumps (one of them standby) will send hot water to reheat coils, finned tube radiation and unit heaters. Hot water temperature will be reset based on outside air temperature. The hot water heating pumps will be on the emergency power system.

Energy efficient options including renewable energy and heat recovery will be studied during the design phase and reviewed against DSF AE standards in place at the time to optimize efficiency and associated life-cycle costs.

5.12.5 Central Air Handling Systems

Ventilation air through intake louvers shall be ducted to the air handling unit. Lower level air handling systems serving spaces such as the Vivarium will require intake louvers to be located 13 ft above grade per DSF standards. Ductwork shall be designed for proper mixing of outdoor air and return air so that stratification does not occur before air handling unit heating coils. The outdoor and relief air distribution systems will be sized to utilize a full economizer (free cooling) mode of operation when outdoor air conditions permit. Special attention must be given to intakes on 100% outdoor air systems to prevent the introduction of snow.

Minimum outside air requirements will meet or exceed the requirements of the Wisconsin Administrative Code, and the ventilation rates of the American Society of Heating, Refrigeration and Air Conditioning Engineers (ASHRAE) Standard 62.1. Verification of the minimum outside air quantities will be done through use of airflow measuring stations located in the outside air intake ductwork. The following spaces will be heated but not necessarily ventilated or mechanically cooled:

- Stairwells
- Miscellaneous Storage areas (unless the usage dictates otherwise)
- Entrance Vestibules
- Mechanical Equipment Rooms

Depending upon the size and configuration of the air handling units, traditional ~~in~~ modular or custom/semi-custom variable volume air handling systems will be utilized. These air handling units will be installed in the penthouse mechanical rooms with potential dedicated air handling units located on the lower level. The units will contain a chilled water coil section, steam coil section, access sections, filter section, supply fan, return fan and others such as blender sections (as necessary) per DSF Standards. The HVAC equipment in the mechanical rooms shall be designed to provide full access for filter replacement, coil replacement, fan shaft removal and any other equipment maintenance and replacement procedures.

Specific laboratory air handling system design criteria are contained in section 5.12.14

5.12.6 Indoor Air Quality

All air handling systems will incorporate the following Indoor Air Quality features:

- Ventilation (outdoor air) quantities will follow the recommendations of ASHRAE 62.
- Ductwork will be constructed of sheet metal and will not be lined, except where necessary for acoustical purposes.
- Ductwork is specified to be covered during construction.
- Air handling units will be specified with stainless steel drain pans that are pitched.
- Air handling units will be dual wall construction.
- Air handling systems will be provided with bag filters.
- All VAV boxes will be designed with booster coils allowing minimum airflows without over cooling the space.

5.12.7 Energy Recovery

Energy recovery is to be evaluated via Life Cycle Cost Analysis to temper incoming outside air to the air handling units. Various energy recovery options are to be considered for labs and Vivarium, including run-around-coils and energy recovery wheels. The energy recovery systems shall be reviewed in accordance with DSF standards in place at the time of design.

5.12.8 Air Distribution

Concealed supply air ductwork system will be externally insulated; exposed duct will not be insulated. No lining will be used in the supply air stream. Concealed ductwork shall have flexible fiberglass insulation. Fiberglass insulation shall be pinned in place on sides and bottom when the ductwork exceeds 24" wide. All transfer ducts located in sensitive areas will be lined for acoustics.

Specific laboratory air distribution design criteria are contained in section 5.12.14

5.12.9 Building Exhaust Systems

General building exhaust fans shall be located in the mechanical rooms per DSF standards and shall discharge through louvers in the wall of the mechanical rooms or through the roof of the mechanical rooms. Laboratory exhaust systems will consist of ductwork appropriate to the use and discharged at the roof with high velocity, up-blast, roof mounted exhaust fans designed for such use.

Specific laboratory exhaust system design criteria are contained in section 5.12.14

5.12.10 Terminal Heating Devices

Finned tube radiation will be provided in exterior spaces with large glass areas. All variable air volume (VAV) terminal units will be provided with reheat coils. VAV units will modulate from maximum to minimum airflow prior to opening the hot water valve to the reheat coils. A VAV unit will be furnished for each thermostatic zone. Each thermostatic zone will take into consideration exposure, occupancy schedule, and space use. Cabinet unit heaters will be installed in entry vestibules and at doors leading to the outdoors. Cabinet unit heaters will be hot water type with wall-mounted thermostat and be recessed wall type whenever possible. Unit heaters will be provided in mechanical rooms.

5.12.11 Temperature Controls

Direct digital controls with electric actuation will be used to control the air handling units, booster coils, VAV boxes, wall fin and all other HVAC systems. All cabinet unit heaters and unit heaters are to have electronic control. All control valves and dampers are to have electric actuation. Air handling units will be provided with economizer controls. A minimum of 24 hours of temperature control training will be specified. Controls will be integrated with the campus wide Automation System.

5.12.12 Testing, Adjusting, and Balancing

The building will be tested, and balanced in accordance with AABC or NEBB Standards.

5.12.14 Laboratory HVAC Systems

Safety

The laboratory HVAC system should promote the safe operation of the building and the health and comfort of the occupants. The laboratory environment may contain harmful chemical vapors, particulates and biological aerosols. These hazardous substances must be continuously removed from the breathing zone of the laboratory users. In addition, a safe environment should be maintained around the building.

The HVAC design will be based on regulatory requirements and guidelines along with good engineering practices. Code requirements are a minimum standard.

Primary Containment

The primary containment in laboratory ventilation consists of chemical fume hoods and other ventilated enclosures which operate under negative pressurization with respect to the laboratory. They are designed for preventing personnel exposure to hazardous materials.

Hoods should be located more than 10 feet from any door or doorway, with the exception of secondary exits, and should not be located on a main traffic aisle.

With the view of energy and capital savings, the hood should be normally operated at 18" vertical sash opening. Sash stops shall be provided and the normal operating sash position shall be labeled. The sash will be fully open only during set-up or take-down operations. Horizontal sashes or combination of vertical-horizontal sashes can be used.

Chemical fume hoods should maintain an average face velocity of 100 feet per minute $\pm 10\%$. The constant volume hoods designed to operate at 18 inch vertical sash opening will develop lower face velocities when the sash is raised above this limit. Under no circumstances shall face velocities drop below 50 fpm ± 3 @ full open sash.

Each fume hood shall be equipped with a local monitoring device to allow convenient confirmation of adequate hood performance. All laboratory fume hoods must be equipped with visual and audible alarms warning of unsafe airflow.

Any fume hood which designated by the Environmental Health and Safety Authority as especially hazardous shall have a dedicated duct, fan, and if required, treatment system. Fume hoods in this category may include radioisotope hoods in accordance with the following criteria:

Radioisotope Hoods

Radioisotope hoods should be constructed from seamless stainless steel with coved corners for easy cleaning. Hood air foils and baffles should be adjustable and removable for cleaning. Radioisotope hoods should operate at an average face velocity of 125 fpm. Exhaust ducts and collars should be welded.

Radioisotope hoods should have individual exhaust and should be provided with housing for bag-in and bag-out HEPA and/or Carbon filters.

Biological Safety Cabinets

The primary containment for the hazardous agents generated by microbiological procedures is provided in biological safety cabinets by negative pressurization and high efficiency HEPA filters. This subject will be detailed in section: "Biosafety".

Secondary Containment

Secondary containment is provided by the negative pressure of the laboratory space relative to corridors and surrounding non-laboratory spaces. To effectively maintain the negative pressure in the laboratory the use of operable windows or doors to the exterior should be avoided. Doors to laboratories should be equipped with closers, must remain closed as much as possible and should not be held open. If the direction of airflow is deemed critical, monitoring devices shall be used to signal or alarm the inadequate pressure relationship of adjacent spaces.

The laboratory spaces will be continuously ventilated 24 hours per day.

Division 5: Pre-Design Concept

Supply air shall be effectively distributed into all portions of the laboratory space by ceiling diffusers or perforated ceiling panels, without creating drafts at exhaust hoods. The maximum supply air velocity in the vicinity of fume hoods and biological safety cabinets shall be 50 feet per minute at 6 feet above the floor.

Air from laboratories and other spaces which might contain hazardous materials shall be exhausted outdoors and not recirculated.

Air from offices and other clean areas may be recirculated or directed toward negative pressure laboratories.

Other Exhaust Devices

Canopy Hoods - Hoods over work areas or equipment used to capture heat or steam. The recommended design flow rate is 75 cfm per linear foot of open perimeter.

Snorkels: Small capturing cones attached to an adjustable exhaust arm, suspended from the wall or ceiling, to capture heat or fumes from equipment or processes. Typical flow rates are 100-200 cfm.

Vented Cabinets: Vented Cabinets used to store hazardous, corrosive, toxic and other health hazard storage cabinets may be connected to an exhaust system, providing a negative pressurization inside the cabinets. Venting of flammable liquid storage cabinets should be reviewed with the Authority Having Jurisdiction.

Slot Exhaust: Slot exhaust openings are used to draw away locally generated fumes.

Down draft units: Used for benchtop working station exhaust.

Equipment Vent Connections: Exhaust ports will be provided for equipment requiring direct exhaust connection. Some equipment may have a separate exhaust system.

Emergency and Standby Power Considerations

Emergency and standby power considerations must be carefully analyzed in connection with laboratory systems.

Emergency power supply should be implemented if a definite potential for catastrophe such as explosion, fire, violent ejection of chemicals or other life-threatening situations is present. Fire detection and alarm systems, elevators, fire pumps, public safety, communication and monitoring systems and processes where current interruption would produce serious life safety or health hazard shall be on emergency power.

Standby power should be provided to serve loads such as heating, ventilating and refrigerating systems, smoke removal, sewage disposal systems, lighting systems, data processing, communication systems, and processes that, when stopped, could create a hazard, discomfort, serious interruption, damage to product or process.

Laboratory equipment involving tests and storage of research media under specific environmental conditions should be provided with standby power.

Standby power should be provided to exhaust manifold fans serving laboratory areas.

Specific standby power requirements will be identified in the Design Development phase.

Redundancy

Laboratory air handling systems are to be comprised of multiple units serving common supply risers such that there is a spare or redundant unit that functions as a standby unit in case a primary unit fails.

Division 5: Pre-Design Concept

Adaptability

Laboratory ventilation systems should be designed to be adaptable to changes of research and teaching protocols and building operations. The systems must be easily modified so that ventilation can be provided to new sources of hazards as they appear in the laboratory.

Modularity is one of the key concepts to an adaptable laboratory HVAC system. The HVAC laboratory system should be designed as an assembly of repetitive modules. Each laboratory planning unit should have supply air diffusers, exhaust grilles, terminal air flow control device, with capability for individual temperature control based on zoning. This equipment, ducts, and grilles will be repeatable throughout the building such that all of these components can easily be located.

The laboratory ventilation system shall be flexible, allowing timely and cost effective changes over time without affecting the performance and operation of the building HVAC system. Careful consideration must be given to the future capacity of the HVAC systems. Both space and electrical capacity should be considered. Providing capabilities to support additional future fume hoods is part of the flexibility concept.

Some laboratory spaces, exceeding the basic air quantity or air flow requirements, will need special HVAC considerations.

Design Criteria	Summer		Winter	
	Temp	RH	Temp	RH
INDOOR DESIGN CONDITION				
Laboratories and Laboratory Support	76°F	50%	68°F	30%
Office and Office Support	76°F	50%	68°F	30%
Conference, Lounge	76°F	50%	68°F	30%
MDF (telecommunications) room	80°F		60°F	
IDF (telecommunications) room	80°F		60°F	
Server rooms	75°F	50%	68 F	30%
Mechanical spaces	80°F	-	60°F	-

Note: The operating/comfort conditions for each laboratory space are presented in Detailed Space Requirements sheets. They may be different than the above design conditions used for sizing the HVAC systems.

FILTRATION

Prefilters and final filters should be provided on all air conditioned spaces. Prefilter efficiency should be 35% and final filter efficiency shall be 85%. HEPA filters may be required for some spaces as listed on the Detailed Space Requirements sheets.

VENTILATION RATES	Minimum Outside Air	Minimum Air Changes per Hour
Laboratory, Laboratory Support	100%*	6-10**

*Refer to Detailed Space Requirements sheets. Air from some spaces may be recirculated.

** Refer to Detailed Space Requirements sheets. 10 air changes minimum for hazardous spaces. 6 air changes for non-hazardous. Air changes per hour may be set back to 4 AC/H during unoccupied times.

PRELIMINARY HEAT GAIN FROM LABORATORY EQUIPMENT

Research Laboratory	25-30 Btu/h ft ²
Teaching Laboratory	20-25 Btu/h ft ²
Laboratory Support	50-75 Btu/h ft ²
MDF Room	340 Btu/h ft ²
IDF Rooms	220 Btu/h ft ²
Server Rooms	850 Btu/h ft ²

Heat gain from laboratory equipment will be calculated during the design phases.

Basic Systems and Controls

The laboratory HVAC system should be controlled to ensure operational safety, regulatory compliance and satisfy process constraints as well as occupant comfort. A well-controlled system will provide flexibility and minimize the operational cost of the building.

A typical control system should provide the following minimal safety requirements in response to abnormal situations:

- Annunciate the equipment failure to a monitoring center and turn on the existing standby equipment.
- Maintain relative levels of pressurization in the laboratories.
- Stop the air supply to the laboratory, resulting in an increased negative pressurization level in case of fire or smoke detection in the laboratory. The exhaust fans should continue to operate at a level that facilitates a safe evacuation of the building through doors between pressurized spaces. Reducing the level of exhaust to a desired pressurization could be obtained by ramping down the exhaust fans or by activation of bypass dampers on exhaust plenum. Capability of operating doors under fire alarm conditions must be tested and documented as part of the commissioning process.

HVAC control systems will be direct digital control with electronic actuation. Laboratory airflow control can be accomplished by a variety of system types summarized below.

Constant Volume - Regulated

Constant volume - regulated system is the minimum first cost system suitable for the laboratory supply and exhaust air. The constant volume regulators, placed on the supply and exhaust ducts in each laboratory room, must be accurate to $\pm 10\%$ of design flow and should be pressure independent. They must be specifically designed for laboratory use and have a minimum of five years of installed field operating history. Commercial components are not acceptable.

As a minimum, each fume hood within this system should have a central alarm connection. Interlocked, variable speed, supply and exhaust fans will provide stability in system operation and flexibility for future changes.

The advantage of this system is its simplicity and relatively low cost. The use of constant volume regulators will simplify initial and subsequent air balances of the building. The disadvantages consist of high energy consumption and limited adaptability.

Two Position Constant Volume

The two-position constant volume system provides two levels of operation of laboratory ventilation: one for normal occupancy and the other for unoccupied. Minimum ventilation rates for normal and unoccupied levels of operation are set in each laboratory room. Interlocked, variable speed fans and terminal level controls will adjust the air flow to occupied or setback conditions, for both supply and exhaust systems without affecting the fume hood operation.

The system, as a minimum combination of first cost and operating cost, is simple and energy efficient. Energy savings is limited in laboratory buildings with high density of fume hoods, where the minimum airflow rates should continuously satisfy the requirements for safe fume hood operation. Since the mechanical systems should be sized for high peak loads the two-position constant volume approach has no impact on the building capital equipment cost.

Variable Air Volume (VAV)

The variable air volume system controls the supply air and the exhaust flow rates in laboratory spaces to maintain the desired pressurization levels. Each fume hood is controlled to maintain a constant face velocity at any sash opening by varying the hood exhaust air flow. The VAV system provides temperature control according to the thermal conditions in the room and maintains the minimum room ventilation rate at any time. The system is self-balancing and should be integrated into the facility management system. Flexibility and diversity in operation should be applied for sizing the airflow devices.

A higher level of complexity and maintenance and higher capital cost of controls are the disadvantages of variable volume systems. Part of the initial cost of control system is offset by applying system diversity and downsizing the equipment components accordingly.

A considerable amount of energy could be saved by implementing a policy of closing the sashes of fume hoods after operating hours.

Division 5: Pre-Design Concept

Ductwork and Fans

Locate duct shafts to allow for efficient duct layouts to minimize duct lengths.

SUPPLY AIR DUCTWORK

Supply air duct system shall be galvanized steel of minimum 4 inch water gauge pressure class for mains. Branch ducts shall be minimum 2 inch class. Sealing, reinforcing and supporting should be according to SMACNA standards.

Supply duct lining is not recommended in laboratory spaces.

EXHAUST AIR DUCTWORK

Fume exhaust ducts should be constructed of materials compatible with chemicals to be carried in the air stream. The following materials are available for exhaust ductwork: Galvanized steel, PVC coated galvanized steel, 304 stainless steel, 316 stainless steel, and fiberglass reinforced plastic. Stainless steel type 304 or 316 shall be used in the chemistry areas. Galvanized exhaust ductwork will be used in the biology areas and non chemical areas. Longitudinal sections of exhaust ducts should be continuous seamless tube or continuously welded formed sheet.

Sound absorbing interior lining or other sound absorbing devices should not be used in the exhaust ductwork.

Velocity in fume exhaust duct should range 1,600-2,000 feet per minute.

All fume hood exhaust ductwork shall be under negative pressure.

Exhaust air filtration may be required to reduce the concentrations of contaminants in exhaust discharge. Future activities may require HEPA filtration, charcoal filters, or chemical scrubbing. Sufficient space should be allocated for these type of devices which may be added as independent exhaust systems. Access ports upstream of fume hood should be provided for exhaust air sampling.

Balancing and control dampers of the exhaust system shall fail open in event of failure.

Fire dampers shall not be placed in fume exhaust ducts.

MANIFOLDING EXHAUST SYSTEMS

Exhaust ducts from chemical fume hoods and other special exhaust systems within the same laboratory unit may be combined into an exhaust manifold. A laboratory unit is defined in NFPA 45 and may extend to the area of an entire floor or building. Compatibility of sources, as defined in ANSI/AIHA Z9.5, should be considered in manifolding the fume hood exhaust. A manifold system has the advantage of diluting the effluents inside a combined exhaust system, improving the system flexibility and reducing the initial as well as operating and energy cost.

Exhaust air from each laboratory unit, which may include fume hood and other exhaust systems, shall be separately ducted outside the building, to a mechanical space or shaft.

To further increase fume exhaust dilution, the manifolded fume exhaust systems may be combined into a common laboratory exhaust system at this point.

EXHAUST FANS

Fume exhaust fans shall be constructed of materials compatible with chemicals present in the exhausted air. They will be located on the roof such that no positively pressurized ductwork exists in the building.

Fume hood exhaust fans of manifolded exhaust systems should have a degree of redundancy such that the failure of a single fan does not render the operation of the ventilation system unsafe.

Manifolded fume hood exhaust fans should be provided with standby power.

Building Exhaust Stacks and Air Intake

Division 5: Pre-Design Concept

The fume exhaust stacks must be above the highest point of the building, including mechanical penthouses and roof parapets, to facilitate the removal of hazardous materials and ensure safe dilution levels. The height of the fume exhaust stacks will be carefully determined in conjunction with local codes and regulations or a wind tunnel analysis. The height of the stacks and their location on the roof are critical to safe building operation and the safe of neighboring sites.

Fume exhaust stacks must be minimum ten feet above the adjacent roof line to avoid exposing the maintenance personnel to the direct upward blast of the fume exhaust.

The discharge velocity from exhaust stacks should be maintained at a minimum of 3,000 feet per minute to counteract any reentrainment due to varying wind direction or area environmental features. Exhaust stacks should not be located within enclosures or architectural screens. Architectural masking structures may be used as long as the requirements of this section are met and the stack extends at least 8' above the masking structure unless a wind tunnel analysis indicates otherwise.

Recirculation of hazardous fumes from exhaust stacks on the roof to the outside air intakes of building ventilation systems should be prevented. It is recommended that building air intake be located on the lower one-third of the building and high enough above the ground to avoid dust or vehicle exhaust. If located on the roof, air intakes should not be placed near the edges of a wall or roof.

The location of the fume exhaust stacks and the building air intakes should not depend on the prevailing wind directions. More careful risk analysis is desirable to analyze possible cross-contamination as well as the effect of outside wind conditions and surrounding buildings, hills, trees, and other features which cause turbulent flow around the laboratory building. The location and height of the exhaust discharge in relation to the building intakes, the prevailing winds, and the building boundary layer created by the air flow pattern over the building, may need to be studied to minimize any re-entry of exhaust air into this and adjacent buildings. Based on the complexity of the project, the use of specialized techniques such as wind tunnel modeling or numerical simulations may be contracted by the owner.

Building Management Systems

The laboratory building should be provided with a micro-processor based direct digital control building automation/energy management system. This system shall provide energy management controls in all spaces and monitoring of the laboratory controls.

A personal computer should be provided as an operator interface. The PC will store record data, provide analysis and reporting functions, and act as a graphical user interface with the networked controllers.

Unsafe levels of operation of the exhaust system should be indicated by fume hood monitors in the rooms affected and should be capable of coupling with a central alarm monitored by building maintenance personnel. Local codes may require certain emergency or fire detection, monitoring and alarming which may affect the design of the laboratory ventilation system.

Monitoring of critical parameters of the ventilation system is important for safe operation and effective maintenance and management of the building. HVAC operational parameters of laboratories, cold and warm rooms, animal rooms and other critical spaces, should be recorded, reported, and alarmed.

A high level of control and functionality should be provided by an integrated laboratory and building control system. The monitoring of the complete system should be performed by the centralized facility management system providing graphical displays and analysis tools, centralized alarm reporting, real time status and custom reports, automatic system-wide emergency responses and maximized energy savings. The Building Automation System should utilize distributed processing for speed, stability, and system reliability. The distributed controllers will be networked to share information.

5.13 Electrical Systems

5.13.1 Applicable Codes, Guidelines, and Standards

Design and construction codes and standards are listed below.

The codes and standards listed are minimum requirements. Nothing is to prevent the architect, engineer, or consultant from exceeding the applicable requirements. In the case of laboratory related research buildings, the recommendations of the guidelines below and the standards and requirements suggested by the design team will often address issues not sufficiently covered in local building codes.

In all cases the most recent editions of referenced standards apply.

- IEEE Institute of Electrical and Electronics Engineers
- IESNA Illuminating Engineering Society of North America
- NECA National Electrical Contractors Association
- NEMA National Electrical Manufacturers Association
- UL Underwriters Laboratories
- NFPA 70 2011 National Electric Code
- NFPA 72 National Fire Alarm code
- NFPA 101 Life Safety Code
- NFPA 110 Standard for Emergency and Standby Power Systems
- NFPA 780 Standards for the Installation of Lightning Protection Systems
- Wisconsin Enrolled Commercial Building Code
- State of Wisconsin, DOA, Division of State Facilities Master Specifications
- Division of State Facilities (DSF) Electrical Systems Standards & Design Guidelines
- DSF Policy and Procedures Manuals for A/Es
- DSF Day Lighting Standards for State Facilities
- University of Wisconsin-LaCrosse Design Standards

5.13.2 Basic Design Criteria

1. Load Calculation Criteria:

<u>Functional Area</u>	<u>Load Density (VA/Sq Ft)</u>
Lighting	1.0
Office Receptacles	1.5
HVAC	3.0
Elevators	0.75
Cooling Equipment	Remote Site

2. Secondary Design Voltages:

Motors larger than ½ HP	480V, 3 phase, 3 wire + ground
General Lighting	277V, 1 phase, 2 wire + ground
Receptacles & motors less than 1/2 HP	120V, 1 phase, 2 wire + ground

3. Equipment Sizing Criteria (Preliminary estimate):

- A. The total capacity of the service entrance switchboard shall be 1000Kva.
- B. Branch Circuit Load Calculations:

Lighting	Actual installed VA
Receptacles	180VA per outlet
Special Outlets	Actual installed VA of equipment
Motors	125% of motor VA
- C. Demand Factors:

Lighting	125% of installed VA
Receptacles	100% of first 10Kva installed plus 50% of balance

Division 5: Pre-Design Concept

Motors	125% of VA of largest motor plus 100% of VA of all other motors
Fixed Equipment	100% of total VA installed

D. Minimum Bus Sizes:

480Y/277V Lighting Panels	100A
480V Equipment Panels	225A
280Y/120V General Receptacle Panels	225A
480V Motor Control Panels	600A

E. Diversity Factor:

A diversity factor shall be used per the 2003 Wisconsin Electrical Code (Comm 16.2392), in establishing power service, feeders, and equipment capacities.

F. Spare Capacity:

25% spare capacity to accommodate function changes over the life of the building shall be included in the design of the power distribution system. Power distribution equipment shall be sized to reserve 20% space for physical expansion.

H. Compliance with Wisconsin Governor's Executive Order #145 shall be discussed with DSF as the design progresses.

5.13.3 Electrical Service

Phase I

Electrical service shall be obtained from the existing spare switch and fuse units from the campus pad mounted primary switch unit SG-41 or SG-30. Service voltage should be 4,160 volts.

Additional underground duct bank shall be required to be installed from the campus pad mounted primary switch unit SG-41 or SG-30 to the new addition. Spare duct bank shall be included in duct package.

Primary service switch gear shall consist of a single primary 5Kv switch and fuse unit, 1000Kva, 4160 to 480/277 unit substation less flammable oil filled transformer, 1600A, 277/480v main breaker with GFI relay, 1600A bus and distribution breakers. Surge arrestors shall be provided on the primary side of the primary switch. Transformers and main switch shall be sized in accordance with State electrical code and DSF guidelines. A 75Kva, 480volt to 120/208volt step down transformer shall be connect to a 225A, 120/208volt, 3 phase, 4 wire branch circuit panel board. A separate 480v service shall be provided as required if fire pump is required for the project. Ground bus shall be installed round the perimeter of the electrical room.

Phase II

Electrical service shall be obtained from the existing switch and fuse units from the campus pad mounted primary switch unit SG-28. Service voltage should be 4,160 volts. Existing unit substations shall be replaced with new unit substation.

Primary service switch gear shall consist of a single primary 5Kv switch and fuse unit, 1000Kva, 4160 to 480/277 unit substation less flammable oil filled transformer, 1600A, 277/480v main breaker with GFI relay, 1600A bus and distribution breakers. Surge arrestors shall be provided on the primary side of the primary switch. Transformers and main switch shall be sized in accordance with State electrical code and DSF guidelines. A 75Kva, 480volt to 120/208volt step down transformer should connect to a 225A, 120/208volt, 3 phase, 4 wire branch circuit panel board.

5.13.4 Normal Power Service and Distribution (Phase I & Phase II)

One (1) 277/480volt, 3 phase, 4 wire branch circuit panel board shall be provided on each floor for lighting and receptacle loads. Each 277/480volt panel should be connected to the 277/480volt distribution switchgear located in the distribution electrical room. A 75Kva, 480volt to 120/208volt step down transformer should be provided for receptacle loads. A digital meter shall be installed in each lighting panel to meter lighting loads.

Two (2) 120/208volt, 3 phase, 4 wire branch circuit panel board shall be provided on each floor for receptacle loads. Each 120/208volt panel should be connected to the 277/480volt, 3 phase, 4 wire branch circuit panel board located in the electrical closet space on each floor via the 480-120/208V step-down transformer.

Division 5: Pre-Design Concept

The branch panel boards serving general loads throughout the programmed floor space shall be located in dedicated electrical closets/rooms, two per floor.

New 120/208volt panel boards shall be double tub type with 84 circuit capacity. Panel boards shall have copper bus with a separate ground bus. All panel boards shall have the entire front trim hinged to the box with a standard door within the hinged trim cover for access to breakers.

Lighting should operate at 277volts, motors where possible shall operate at 480v, 3 phase, and general receptacles and computer loads should operate at 120volts.

5.13.5 Emergency /Standby Service and Distribution (Phase I)

The emergency power source shall be obtained from a new diesel fueled, 150Kw, 277/480volt, 3 phase, 4 wire generator and distribution system located in the new addition. Generator capacity shall be increased based on the requirement for fire pump if required.

An emergency distribution panel board with dedicated sections for each emergency branch shall be provided. Two automatic transfer switches and distribution panel boards shall be provided; one panel board for life safety and one panel board for optional loads.

Life safety distribution shall be provided for all emergency egress lighting, fire alarm system, and communications power.

The optional emergency distribution shall be provided for mechanical loads for building freeze protection such as boilers, heating pumps, sump pumps, sewage ejector if required and lab equipment as determined by design and usage. Generator and distribution shall be sized for phase I and phase II.

Emergency distribution panel, transfer switches and distribution panels shall be located in a dedicated electrical room separate from the normal electrical distribution room.

5.13.6 Grounding System

A complete low-impedance grounding electrode system shall be provided for the facility. The ground electrode system shall include the main water service line, structural steel, Ufer ground, and ground field. The equipment grounding system shall extend from the building service entrance equipment to the branch circuits. The system shall be bonded to the existing grounding system associated with the existing Cowley Hall. All grounding system connections shall be made using exothermic welds or irreversible compression connections.

All feeders and branch circuits shall be provided with an equipment ground conductor.

5.13.7 Lightning Protection System

A complete lightning protection system meeting all requirements of UL shall be provided, complete with air terminals on the roof, bonding of all mechanical equipment and stacks, bonding of structure and all metal parts, grounding conductors, ground rods, connectors, straps, etc.

5.13.8 Lighting System

All lighting and controls shall comply with State of Wisconsin requirements and campus standards. Lighting fixtures shall consist primarily of 2x4 recessed lens volumetric type fixtures. Fixtures shall contain electronic ballasts with 25 watt or 32 watt, T8, SP5000 (5000K) lamps. Lighting layouts shall provide an average of 30fc maintained ambient light level.

The use of high-efficiency decorative and suspended linear indirect fixtures may be considered. Fixtures may be either fully indirect or a combination of direct/indirect. Suspended fixtures shall utilize multiple T8 lamps with multiple electronic ballasts to allow for inboard-outboard dual level switching.

Storage rooms and utility spaces such as janitor's closets, mechanical rooms, electrical rooms, etc. with lay in ceilings shall be provided with 2x4 recessed lensed fluorescent fixtures. Spaces without a ceiling shall be provided with industrial type fixtures.

Recessed downlights using compact fluorescent lamps shall be provided where appropriate and required for accenting architectural features.

Emergency egress lighting for interior and exterior spaces shall be provided from the emergency life safety distribution system. Life safety panel boards shall be located on minimum of every other floor. All exit fixtures should be LED source type.

All lighting controls shall comply with the Wisconsin Energy Codes and be a combination of general switching, occupancy sensors, and light level sensors. The interior lighting shall be controlled locally. Exterior lighting shall be connected to the Campus Automation System to coordinate On/Off times with the other exterior campus lighting.

All spaces shall utilize multi-level switching schemes to allow the lighting to be reduced, based on needs within the spaces. Switches shall be provided to allow the occupants to manually turn off lamps as desired.

Occupancy sensors shall be used for automatic off control of lighting circuits.

Emergency egress lighting shall be equipped with transfer relays to allow egress lighting to be switched normally when normal power is available and be operated to on automatically when normal power fails.

Occupancy sensors shall be ceiling or wall mounted depending of space layouts and requirements. Passive infrared (PIR), ultrasonic, or dual-technology (both PIR & ultrasonic) shall be used as required to met the required space requirements.

The use of photo-sensors for "daylight" harvesting shall be considered based on architectural layouts. When adequate levels of daylight are available, the daylight zones shall be controlled to a preset level using automatic dimming controls.

5.13.9 Electrical Wiring Devices

Devices shall be flush mounted and specification grade with white finish. Cover plates should be smooth nylon with white finish.

5.13.10 Fire Alarm System

The fire alarm system shall be a multiplex addressable microprocessor controlled system. The central processing unit should monitor and record all events. All initiation devices shall be programmable and addressable.

Audible and visual signaling devices shall be provided in all public areas including double occupancy offices. Additional signaling devices shall be provided in mechanical equipment rooms. Audio/visual signals shall be placed to cover all areas of the building for alarm signaling. Fire alarm pull stations and visual and audible devices shall be located to comply with public mode operations.

Smoke detectors shall be provided in storage areas, elevator equipment rooms, stairwells, elevator shafts, elevator lobbies, and mechanical equipment rooms. An elevator recall system with all relays and controls shall be provided.

Smoke detectors shall be provided in corridors at all smoke door locations. Smoke detectors shall also be placed inside HVAC ducts at smoke damper locations, upstream of each damper location. This requirement applies to all ducts supplying or returning in excess of 2,000 cfm and/or crossing smoke walls. Addressable control relays shall be provided for air handling equipment shut down.

LCD style alarm annunciator shall be provided at the main entry and in the Emergency Department.

Monitor relays shall be provided for fire protection valves and flow switches.

System shall comply with campus standards for emergency notification systems including, but not limited to, a building wide public address system.

5.13.11 Area of Rescue Assistance System

A complete area of rescue assistance system shall be provided in all stair tower landings. System shall be a stand alone two-way communication system between individual call-in stations and the master control station.

Master control station shall be located adjacent to the fire alarm annunciator panel at the fire department entrance to the building.

5.13.12 Clock System

A complete second impulse type digital clock system synchronized and traceable to NIST atomic clock in Fort Collins, Colorado shall be provided. The system shall provide time correction signaling to all remote clocks via wireless communications. Clocks shall be 4 digit red LED display.

5.13.13 Laboratory Electrical Systems

5.13.13.1 Laboratory Design Criteria

Load Calculation Criteria

Design Voltages

Secondary voltage	
Emergency/standby	- 480Y/277V, 3 phase, 4 wire
	- 208Y/120V, 3 phase, 4 wire
Secondary voltage, normal	
	- 480Y/277V, 3 phase, 4 wire
	- 208Y/120V, 3 phase, 4 wire

Preliminary Design Loads. Overall connected Volt-Amper per Square Foot

Office:

Lighting	- 1.5
Receptacle	- 2.0

Laboratory, Support and Technical Areas:

Lighting	- 3.5
Receptacle - Labs	- 20-35
Receptacle - Laboratory support	- 60-100

Storage:

Lighting	- 0.25
----------	--------

Corridor:

Lighting	- 0.50
Receptacle	- 0.50

Mechanical Areas:

Lighting	- 1.5
Power	- Actual Motor H.P.

Equipment Sizing Criteria

Branch Circuit Load Calculations

Lighting	- Actual installed wattage
Receptacles	- 180 VA per outlet
Surface wireway	- 180 VA per outlet
Special outlets	- Actual installed wattage of equipment served
Motors	- 125% of motor wattage

Demand Factors

Lighting	- 100% of total wattage
Receptacles	- 100% of first 10 kVA plus 50% of all over 10 kVA
Motors	- 125% of wattage of largest motor plus 100% of wattage of all other motors
Fixed equipment	- 100% of total wattage

Minimum Bus Sizes

277V Lighting panels	- 100A
480V Lab Equipment Panels	- 100A
120V Lab Equipment Panels	- 225A
120V General Receptacle Panels	- 225A

Division 5: Pre-Design Concept

480V Motor Control Center – 600A

Feeder Size

Feeders from service entrance to distribution panels to be sized the same as the distribution panel bus size. Distribution panels will be sized for 20% future capacity and space available.

Feeders from distribution panels to secondary panels to be sized the same as the secondary panel bus size.

Lighting Criteria

Design Lighting Levels, Maintained Foot-candles

Office: – 40-50 indirect
– 60-80 direct

Laboratory, Support, Technical Area:

Bench and table top – 75-80

Conference: – 50-75

Corridor: – 15-20

Storage: – 20-30

Mechanical: – 10-20

Standby Power Distribution

The following are minimum standby (SP) power densities. High SP distribution may be required.

Laboratories 1 duplex receptacle/module
Laboratory support 2 duplex receptacles/module

LIGHT LEVELS (design lighting levels, maintained footcandles)

Offices 40 fc direct, 30 fc indirect/direct
Laboratory, Laboratory Support 70 fc direct, 60 fc indirect/direct

Animal Holding 30 fc

Light levels listed here are generalized; refer to Detailed Space Requirements sheets for further information. Generally, indirect lighting will allow light levels to be set slightly lower.

5.13.13.2 Normal Service and Distribution

See 5.13.3 and 5.13.4.

5.13.13.3 Emergency and Standby Service Distribution

See 5.13.5.

Uninterruptible Power System (UPS)

The type of system to provide a clean and uninterruptible source of power to the facility, if any, will be determined during the DD phase.

Grounding System

Division 5: Pre-Design Concept

All parts of the normal and emergency power distribution system will be provided with a wired equipment ground conductor. This system will extend from building service transformer to the branch circuit load or device.

5.13.13.4 Interior Lighting Systems

See 5.13.6

5.13.13.5 Telephone/Data Systems

See 5.14.

5.13.13.6 Fire Alarm System

See 5.13.10.

5.13.13.7 Security System

Discuss need for security systems in the DD phase. The following is a generic listing of systems typical for consideration in labs. The security system will consist of two separate systems. A closed circuit television CCTV surveillance system and an intrusion detection and admittance system. All equipment and wiring will be provided by the owner under separate contract. The electrical contractor will provide backboards for equipment, conduit cable tray and back boxes only.

CCTV System:

CCTV's camera will be located typically at building exterior locations, lobbies, employee entrances, and loading docks.

Intrusion Detection and Door Access System:

Glass breakage sensors will be utilized for the intrusion alarm system for ground-level only. Audio discriminators will be utilized for area coverage in spaces such as lobbies, open offices, etc., where appropriate.

Card access will be provided at main entrances and at special interior areas requiring controlled access to be determined during detailed design. Eight (8) readers are typically planned per control panel.

Other security features:

- a. Electric mortises and electrified panic hardware.
- b. Egress shall be shunted via motion detectors.
- c. Door alarm contacts shall be flush mounted on the door header.
- d. Local, audible alarms shall occur for door breeches and excessive door-ajar time periods.
- e. Cabling for electric mortise hardware shall be wired through the hinge-side of door.
- f. Security components and panels shall not be located in mechanical rooms, VDER rooms, or electrical rooms, Security and Fire Alarm Systems can however be located in the same rooms.
- g. Fiber optics (DSF recommends coax or Cat 5e) cable will be used for video systems and a hardwired system for access/intercom system wiring.

5.14 Telecommunications Systems

5.14.1 Campus Backbone Cable

Fiber and copper outdoor rated backbone cable shall be provided from nearest data center or other campus wiring hub (User Agency has identified Wing Technology Center as campus hub) via underground signal conduits. Campus cable connections shall be sized minimally at 18 single mode (SM) fiber strands, 18 multimode (MM) fiber strands and 400 pair copper telephone cable. Additional .500 hardline coax may be required to serve cable TV needs. Six (6) new 4" conduits are recommended to be fed into new building from existing signal maintenance hole (MH) #28 as identified on site utility plan. Conduits and cable to proceed under new building slab floor in concrete encased duct bank and turn up into first floor main telecom room (MTR). Depth to be 48" or more below grade with 40" bend radius maintained for all conduit bends. Distance between the MH and the MTR must not exceed 250', otherwise an additional MH should be provided closer to MTR.

Existing signal MH #28 feeds into the MDF of existing Cowley Hall. If current service is to be maintained, this conduit route and MDF will need to be maintained. If existing Cowley Hall is to be demolished, service cannot be maintained via this route. If the entire building is not demolished (if west wing is to be preserved), a new route could be established into any remaining portions of Cowley Hall via signal MH #40 on the west side of the building. It may also be possible to interrupt the signal conduits as they proceed north from MH #40. Due to the age of Cowley Hall, if any portion is to be reused, no communications infrastructure will be salvageable or reused – all should be provided new, unless recent upgrades meeting current DSF standards have occurred.

The site utility plan indicates an existing route between Cowley Hall and Wing Technology Center. The preferred route would be from eastward from MH #28, to 27, the southward to 48, to 47, then appears to enter cable tray (?) under adjacent building and then into Wing MDF. An alternate route appears to run eastward from #27, to 19, southward to 18, to 17, to 15, to 1, then westward to 2, to 3, to 4 then into Wing MDF. Physical verification of routes will be required, including conduit/manhole fill/access.

5.14.2 Telecommunications Room (TRs)

See space needs are covered elsewhere for location and sizing of TRs (see below). TRs shall be constructed with walls from floor to deck above, ¾" fire-retardant plywood on all walls, no drop ceiling tiles, anti-static flooring and no windows. Connect TRs with minimum (4) 4" conduits. Doors are typically secured with card access, off public corridors, not trapped by restrooms, elevators or other MEP utilities. DSF standards do not require full-time cooling of TRs. Cooling requirements will vary depending on User Agency requirements, but typically begin at about 1 ton or 12kW per rack or cabinet. Provide cold air supply to front of racks and return grille at back of racks. Depending on user requirements, an additional 1 ton of cooling should be added for every additional data rack in the TR. Temperature to be maintained 24x7x365 between 68 and 77 degrees F and relative humidity between 40 and 55%. Two or three data racks are typically required, each having two dedicated power circuits. Additional power circuits are required on walls for wall mounted equipment and convenience. Overhead cable runway to be connected to top of all data racks and securely fastened to at least two walls for stability.

The main TR (MTR) may also be considered the building entrance facility (BEF). Cooling needs may increase (up to 5 tons) and power requirements will also increase.

Systems typically located within TRs include cable and electronics for: voice, data, paging, security CCTV, access control, fire alarm, audio-visual, cable TV, cable connections to other floors, cable connections to outside campus or telco services, connections to roof or antennae, other systems as determined by User Agency or local departments.

5.14.3 Telephone System

Telephone system hardware, electronics and handsets are presumed to be provided by the User Agency. Voice cabling, pathways (conduit, back boxes and cable tray) outlets, faceplates, termination blocks, backboards, termination and testing are included as part of this project. Method of serving voice requirements should be determined from User Agency, whether PBX, Centrex or VoIP. Method of voice service will impact backbone fiber and copper cable design. Backbone cable and horizontal cabling are included as part of this project.

5.14.4 Data System

Data system electronics including switches, routers, servers, distributed (rack mounted) uninterruptible power supplies and other electronic equipment are presumed to be provided by the User Agency. Data cabling (backbone fiber optic and horizontal copper), pathways (conduit, back boxes and cable tray), outlets, faceplates, patch panels, equipment racks, terminations and testing are included as part of this project.

5.14.5 Cable TV System

CATV system electronics such as tuners, source devices, signal processors, TVs and amplifiers are presumed to be provided by the User Agency. Amplifiers are User Agency provided due to the unknown nature of the cable feed, satellite feed and signal level or quality. CATV cabling, pathways, backboards, station end terminations and testing are included as part of this project.

5.14.6 Audio-Visual Instructional Systems

Responsibility to provide AV systems varies by campus. Until responsible party is determined by project team, it should be assumed that all AV infrastructure (including power and conduits) is to be included as part of this project, but with User Agency input and direction. Campus technical staff typically directs the engineer regarding use of preferred products and applications. In some cases the devices would be indicated on the plans, but equipment specifications may not be issued as User Agency may furnish the equipment. AV system to include screens, projectors, lecterns, user interface control devices, sound systems (microphones, amplifiers, speakers) environmental control interface (shades, screen, lights), pathways, faceplates, patch panels, equipment racks, terminations and testing. A cabinet space should be designated in every lecture hall of 50 persons and larger to house AV equipment and cabling. This space could be for an AV rack mounted in a closet, in a lectern or under casework. Some AV equipment may be located in the TR on that floor (but as a general rule is not). Provide means of securely mounting overhead projector from ceiling structure.

5.14.7 Security Access Control Systems

Responsibility to provide access control systems varies by campus and building use. At a minimum, the engineer shall provide back box, conduit and raceway for card readers and other devices as required by User Agency back to the TR. If directed by User Agency, engineer may provide specifications for preferred equipment.

5.14.8 Security Closed Circuit TV System

Responsibility to provide CCTV systems varies by campus and building use. At a minimum, the engineer shall provide back box, conduit and raceway for cameras and other devices as required by User Agency back to the TR. If directed by User Agency, engineer may provide specifications for preferred equipment.

5.14.9 Overhead Paging System

Responsibility to provide overhead paging and mass notification systems varies by campus and building use. At a minimum, the engineer shall provide wall space, power and raceway to anticipate requirements. User Agency to determine paging requirements and coordinate with engineer.

5.14.10 General Requirements

Structured cabling system shall be designed so that no horizontal voice or data cable exceeds 295 feet in length. Station voice and data cabling to be Cat 6, 4-pair, UTP copper. Refer to DSF specifications for mandatory, minimum performance criteria. All cable for all systems shall be routed in conduit and cable tray. J-hooks may be permitted in unexposed areas for last few feet of run between cable tray and conduit. Assume use of plenum rated cable until confirmation by mechanical engineer and architect that ceiling spaces are rated as non-plenum. Every workstation outlet assumed to consist of one voice and two data jacks, unless directed otherwise by User Agency. Private offices shall have two workstation outlets located on opposite walls. Open offices with modular furniture shall have minimum of one work station outlet. Design to accommodate cabling needs of special areas such as labs, large lecture halls and ceiling-mounted wireless devices as determined by User Agency, subject to DSF approval.

Division 5: Pre-Design Concept

5.14.11 Wireless Access

The engineer shall be responsible, with User Agency input, to provide Cat 6 cabling to approximate ceiling locations as appropriate for future installation of wireless access points (WAPs). The User Agency shall be responsible to provide WAPs and patch cords, and to adjust placement of WAPs to obtain best wireless coverage. If no User Agency input is provided, engineer shall provide ceiling-mounted data jacks at approximately 50 foot intervals above major corridors and near lecture halls and public areas.

For voice backbone cable requirements and all other requirements not discussed in this narrative consult the DOA Telecommunications Guidelines for Structured Building Wiring Systems. Begin fiber optic backbone cable count between TRs and MTR at 18 strands 50 micron laser optimized MM and 18 strands SM. Station jacks are to be terminated with either TIA 568A or 568B pin configurations. Both are acceptable to DSF. Consult with User Agency and DSF prior to final design to determine which pin out is required on this campus.

Provide grounding and bonding system for all telecommunications systems and equipment bonded to one central location at the main electrical service for the building. Provide telecommunications grounding bus bars in every TR.

Back boxes to be 4x4 with single gang mud ring connected to 1" conduit stubbed to nearest accessible ceiling or cable tray.

5.14.12 Space Requirements

A minimum of one telecom room (TR) shall be provided on each floor. TR size to begin at industry recommended size of 10'x11', centrally located on the floor plan, stacked one above the other. TRs should be located no farther than 250 feet from the farthest voice/data station outlet in order to maintain the required 295' wiring length. Wire lengths beyond this limit may cause systems to fail. Depending on size and shape of building, an additional TR may be required on each floor to maintain wiring lengths of 250' or less. Fewer TRs are better to reduce network electronics, power and cooling requirements. In other words, it is better to centralize the TRs to require only one per floor than to locate (separate) them such that more than one TR per floor is required.

The TR on first level where campus backbone cable enters should be designated as the main TR (MTR) and be sized slightly larger (12'x14' per DSF recommendation) to accommodate campus backbone services and to consolidate all riser cable within the building. The MTR will also serve as the TR for that floor. Because campus cable will also enter into this room, it may also be considered the BEF as described above. Should heavy use by User Agency require more servers, AV or other electronic equipment, larger TRs and MTR may be required.

As noted above, additional spaces for AV equipment will be required in or near larger classrooms. Restricted lengths of AV cable may preclude use of TRs for AV systems. As a general rule, AV equipment should not be located within TRs but be provided within dedicate AV cabinets in or near classrooms. Such equipment can often be located within lecterns.

This code review utilizes the current Wisconsin Building Code which incorporates the 2006 International Building Code and Comm. 62 modifications effective July 10, 2007. It should be noted that the proposal to revise the Wisconsin Building Code to follow the 2009 International Building Code along with updated Wisconsin Comm. 62 modifications has been put forth to legislature and is expected to be adopted September 1, 2011.

6.1 Building Occupancy and Construction Classification

1. The building is to be considered as 2 separate “buildings”; the addition (Phase 1) and the main building (Phase 2). These are to be separated by a 2 hour fire wall.
2. The buildings are considered Type A-3 (Assembly), B (Business), Group H-2, H-3, H4 (Hazardous), and S (Storage) occupancies. The Hazardous occupancies are to be separated from the remainder of the building which will be constructed as non-separated. The H-2 occupancy (Room 415) is to be separated from all other occupancies by a 3 hour fire barrier. This space may only be located on the first or second floor of the facility. The H-3 and H-4 spaces (Room 1, Room 4, Room 6, and Room 415A) are to be separated from each other and all other spaces by 2 hour fire barriers.
3. Because of the height and area of each building they are to be Type IIA construction – non-combustible with protected interior elements. The buildings are to have a minimum 30 foot setback due to the H-2 occupancy.

602.2 Types I and II

Type I and II construction are those types of construction in which the building elements listed in Table 601 are of noncombustible materials, except as permitted in Section 603 and elsewhere in this code.

Table 601-IIA	
Element	Fire-Resistance Rating Requirement (Hours)
Structural Frame	1
Exterior Bearing Walls	1
Interior Bearing Walls	1
Floor Construction	1
Roof Construction	1

Table 602 – Fire Separation Distance		
>30 feet	Group A, B, H, and S	0 Hours

4. With a construction Type IIA the use of combustible materials is limited.

603.1 Allowable Uses

Combustible materials shall be permitted in buildings of Type I and Type II construction in the following applications and in accordance with Sections 603.1.1 through 603.1.3:

1. Fire-retardant-treated wood shall be permitted in:
 - 1.1 Nonbearing partitions where the required fire-resistance rating is 2 hours or less.
 - 1.2 Nonbearing exterior walls where no fire rating is required.
 - 1.3 Roof construction, including girders trusses, framing and decking.
2. Thermal and acoustical insulation, other than foam plastics, having a flame spread index of not more than 25.

Exceptions:

1. Insulation placed between two layers of noncombustible materials without an intervening airspace shall be allowed to have a flame spread index of not more than 100.
2. Insulation installed between a finished floor and solid decking without intervening airspace shall be allowed to have a flame spread index of not more than 200.
3. Foam plastics in accordance with Chapter 26.
4. Roof coverings that have an A, B, or C classification.
5. Interior floor finish and interior finish, trim and millwork such as doors, door frames, window sashes and frames.
6. Where not installed over 15 feet above grade, show windows, nailing or furring strips, wooden bulkheads below show windows, their frames, aprons and show cases.
7. Finish flooring applied directly to the floor slab or to wood sleepers that are fireblocked in accordance with Section 717.2.7.
8. Partitions dividing portions of stores, offices or similar places occupied by one tenant only and which do not establish a corridor serving an occupant load of 30 or more may be constructed of fire-retardant treated wood, 1-hour fire-resistance-rated construction or of wood panels or similar light construction up to 6 feet in height.
9. Stages and platforms constructed in accordance with Section 410.3 and 410.4, respectively.
10. Combustible exterior wall coverings, balconies, bay or oriel windows, or similar appendages in accordance with Chapter 14.

11. Blocking such as for handrails, millwork, cabinets, and window and door frames.
12. Light-transmitting plastics as permitted by Chapter 26.
13. Mastics and caulking materials applied to provide flexible seals between components of exterior wall construction.
14. Exterior plastic veneer installed in accordance with Section 2605.2.
15. Nailing or furring strips as permitted by Section 803.4.
16. Heavy timber as permitted by Note d to Table 601 and Sections 602.4.7 and 1406.3.
17. Aggregates, component materials and admixtures as permitted by Section 703.2.2.
18. Sprayed fire-resistant materials and intumescent and mastic fire-resistant coating, determined on the basis of fire-resistance tests in accordance with Section 703.2.
19. Materials use to protect penetrations in fire-resistance-rated assemblies in accordance with Section 712.
20. Materials used to protect joints in fire-resistance-rated assemblies in accordance with Section 713.
21. Materials allowed in the concealed spaces of buildings of Types I and II construction in accordance with Section 717.5.
22. Materials exposed within plenums complying with Section 602 of the International Mechanical Code.

6.2 Fire Protection

1. Both buildings are to have sprinkler systems installed throughout, with the exception of storage room 415 due to its water reactive contents. Stairs and other vertical shafts which connect 4 stories are to be 2 hour fire rated. Corridors are to have zero-hour fire rated walls.

6.3 Occupant Load and Means of Egress

1. The occupant load of each phase is calculated separately. Phase 1 has an occupant load of 1,876 people. Phase 2 has an occupant load of 2,344 people.

Table 1004.1.1 Maximum Floor Areas Allowances per Occupant

- Business areas – Offices = 100 square feet gross.
- Assembly un-concentrated (tables and chairs) – Conference Rooms, Collabs = 15 square feet per occupant net
- Assembly concentrated (chairs only, not fixed) = 7 square feet per occupant net
- Assembly fixed seating – Classrooms, Auditoria = by seat
- Educational – classrooms = 20 square feet per occupant net
- Educational – shops and vocational – Vivarium, Greenhouse, Herbarium, = 50 square feet per occupant net
- Library Reading Rooms – Specimen Museum = 50 square feet per occupant net
- Industrial Areas – Shop = 100 square feet gross
- Stages and Platforms = 15 square feet per occupant net
- Kitchens – Commercial = 200 square feet gross
- Accessory storage areas, mechanical, equipment rooms = 300 square feet gross.

Phase	No. of Occupants
Phase 1	1,876
Phase 2	2,344

2. Exits from each building/phase are to be considered separately. Final distribution of the spaces within each phase will affect the number of stairs and exiting width required.

1005.1 Minimum Required Egress Width

The means of egress width shall not be less than required by this section. The total width of means of egress in inches shall not be less than the total occupant load served by the means of egress multiplied by the factors in Table 1005.1 and not less than specified elsewhere in this code. Multiple means of egress shall be sized such that the loss of any one means of egress shall not reduce the available capacity to less than 50 percent of the required capacity. The maximum capacity required from any story of a building shall be maintained to the termination of the means of egress.

Assembly/Business with Sprinkler System	Stairways	.2" per occupant
	Other Egress Components	.15" per occupant
For H with Sprinkler System	Stairways	.3" per occupant
	Other Egress Components	.2" per occupant

1025.2 Assembly Main Exit

Group A occupancies that have an occupant load of greater than 300 shall be provided with a main exit. The main exit shall be of sufficient width to accommodate not less than one-half of the occupant load, but such width shall not be less

than the total required width of all means of egress leading to the exit. Where the building is classified as a Group A occupancy, the main exit shall front on at least one street or an unoccupied space of not less than 10 feet in width that adjoins a street or public way.

Exception: In assembly occupancies where there is no well-defined main exit or where multiple main exits are provided, exits shall be permitted to be distributed around the perimeter of the building provided that the total width of egress is not less than 100 percent the required width.

3. The configuration of the stairs means that one area of refuge to be located at each of the stairs in each building with the exception of the third floor of the Main building which requires 2 areas of refuge at each stair.

1007.6 Areas of Refuge

Every required area of refuge shall be accessible from the space it serves by an accessible means of egress. The maximum travel distance from any accessible space to an area of refuge shall not exceed the travel distance permitted for the occupancy in accordance with Section 1016.1. Every required area of refuge shall have direct access to an enclosed stairway complying with Sections 1007.3 and 1020.1 or an elevator complying with Section 1007.4. Where an elevator lobby is used as an area of refuge, the shaft and lobby shall comply with Section 1020.1.7 for smokeproof enclosures except where the elevators are in an area of refuge formed by a horizontal exit or smoke barrier.

1007.6.1 Size

Each area of refuge shall be sized to accommodate one wheelchair space of 30 inches by 48 inches for each 200 occupants or portion thereof, based on the occupant load of the area of refuge and areas served by the area of refuge. Such wheelchair spaces shall not reduce the required means of egress width. Access to any of the required wheelchair spaces in an area of refuge shall not be obstructed by more than one adjoining wheelchair space.

6.4 Plumbing Systems

1. The plumbing fixture count is calculated based upon the occupant load for each phase. Phase 1 has an occupant load of 1,876 people. Phase 2 has an occupant load of 2,344 people. The occupant load is split evenly to accommodate males and females.

Plumbing Fixtures			
Phase 1 (1,876 occupants)	Male Water Closets	1 per 125	8
	Female Water Closets	1 per 65	15
	Lavatories	1 per 200	10
	Drinking Fountains	1 per 500	4
	Service Sink	1	1
Phase 2 (2,344 occupants)	Male Water Closets	1 per 125	10
	Female Water Closets	1 per 65	19
	Lavatories	1 per 200	12
	Drinking Fountains	1 per 500	5
	Service Sink	1	1

1. *Calculations based on Assembly Occupancy – Lecture Halls, etc.*
2. *Wherever more than 500 people congregate and more than the required minimum number of water closets or urinals are provided for males, twice as many of those additional toilet facilities shall be provided for females.*

Comm 62.2902 Plumbing Fixtures

1) Minimum Number of Fixtures

- a) 1) Where more than one water closet is required for males, urinals may be substituted for up to 50 percent of the required number of water closets.

2902.1.1 Unisex Toilet and Bath Fixtures

Fixtures located within unisex toilet bathing rooms complying with Section 404 of the *International Plumbing Code* are permitted to be included in determining the minimum required number of fixtures for assembly and mercantile occupancies.

6.5 Laboratory Codes and Standards

Design and construction codes and standards are listed below.

The codes and standards listed are minimum requirements. Nothing is to prevent the architect, engineer, or consultant from exceeding the applicable requirements. In the case of laboratory related research buildings, the recommendations of the guidelines below and the standards and requirements suggested by the design team will often address issues not sufficiently covered in local building codes.

In all cases the most recent editions of referenced standards apply.

References and guidelines:

American National Standards Institute. ANSI Z358.1: Emergency Eyewash and Shower Equipment.

American National Standards Institute. ANSI/AIHA Z9.5: Laboratory Ventilation.

American National Standards Institute. ICC/ANSI A117.1: Accessible and Usable Buildings and Facilities.

Americans with Disabilities Act (ADA). 1990.

National Fire Protection Association. NFPA 30: Flammable and Combustible Liquids Code.

National Fire Protection Association. NFPA 45: Standard on Fire Protection for Laboratories Using Chemicals.

National Fire Protection Association. NFPA 110: Life Safety Code.

National Institutes of Health. NIH Design Policy and Guidelines. Clinical Center; Research Laboratory; Vivarium; Reference Materials. <http://des.od.nih.gov/planning/nihpol.htm>.

National Research Council. Guide for the Care and Use of Laboratory Animals. National Academy Press 1996.

Occupational Safety and Health Administration, Labor. Code of Federal Regulations: 29 CFR Ch. XVII. § 1910.1450 Occupational Exposure to Hazardous Chemicals in Laboratories.

Project specific references and guidelines:

Lawrence Berkeley National Laboratory. A Design Guide for Energy-Efficient Research Laboratories. <http://ateam.lbl.gov/design-guide>.

U.S. Green Building Council. Leadership in Energy and Environmental Design (LEED) Green Building Rating System. <http://www.usgbc.org/programs/leed.htm>.

Applicable Code Commentary

Uniform Building Code

Occupancy: The laboratory areas shall be classified as a B-2 occupancy.

Fire Separation: Laboratories shall be separated from each other and other portions of the building by not less than a one-hour fire resistive occupancy separation.

Hazardous Materials: The quantities of hazardous materials shall not exceed those listed in Tables 3-D and 3-E of the code.

Exits: Occupants in laboratories having an area in excess of 200 square feet shall have access to at least two exits from the room and all portions of the room shall be within 75 feet of an exit.

NFPA 101: Life Safety Code

Means of Egress: Where exits are not immediately accessible from an open floor area, safe and continuous passageways, aisles, or corridors shall be maintained leading directly to every exit and shall be arranged as to provide convenient access for each occupant to at least two exits by separate ways of travel.

Exit access shall be so arranged that it will not be necessary to pass through any area identified under protection from hazards in Chapter 28.

Corridor Width: The minimum width of any corridor or passageway serving as a required exit, exit access, or exit discharge shall be 44 inches.

NFPA 45: Fire Protection For Laboratories Using Chemicals

Means of Egress: The means of egress for laboratory units and laboratory work areas shall comply with NFPA 101.

Access to Exits: A second means of access to an exit shall be provided from a laboratory work area if any of the following situations exist:

- A laboratory work area contains an explosion hazard so located that an incident would block escape from or access to the laboratory work area.
- A fume hood in a laboratory work area is located adjacent to the primary means of exit access.
- A compressed gas cylinder in use which is larger than lecture bottle size, and contains a gas which is flammable or has a hazard rating of 3 or 4 and would prevent safe egress in event of accidental release of cylinder contents.
- The required exit doors of all laboratory work areas within Class A or Class B laboratory units shall swing in the direction of exit travel.

Furniture and Equipment: Furniture and equipment in laboratory work areas shall be arranged so that means of access to an exit may be reached easily from any point.

Explosion Hazard: Explosion hazard is considered to exist if reactivity rating 4 materials are stored or used, or if highly exothermic reactions or procedures without established properties are planned, or if high pressure reactions are planned. Program information does not indicate that explosion hazards, as described above, exist in this project.

NFPA 30 - Flammable and Combustible Liquids Code

Liquid Classification: Combustible liquids have a flash point at or above 100° F (37.8°C) and are classified as follows:

- Class II: Liquids with a flash point at or above 100°F (37.8°C) and below 140°F (60°C)
- Class III A: Liquids with a flash point at or above 140°F (60°C) and below 200°F (93°C)
- Class III B: Liquids with a flash point at or above 200°F (93°C)

Flammable liquids have a flash point below 100°F (37.8°C) and a vapor pressure not greater than 40 lbs per square inch (absolute) (2,068 mm Hg) at 100°F (37.8°C). Flammable liquids are classified as follows:

- Class I A: Liquids with flash point below 73°F (22.8°C) and a boiling point below 100°F (37.8°C).
- Class I B: Liquids with flash point below 73°F (22.8°C) and a boiling point at or above 100°F (37.8°C).
- Class I C: Liquids with flash points at or above 73°F (22.8°C) and below 100°F (37.8°C).

Storage Cabinets: Not more than 120 gallons (454 L) of Class I, Class II, and Class III A liquid may be stored in a storage cabinet. Of this total, not more than 60 gallons (227 L) may be of Class I and Class II liquids and not more than three (3) such cabinets may be located in a single fire areas, except that, in an industrial occupancy, additional cabinets may be located in the same fire area if the additional cabinets (not more than a group of three (3) are separated from other cabinets or group of cabinets by at least 100 feet (30 M).

Division 6: Code Review

In addition to the above standards it will be necessary during the design phases of the project to work closely with the owners representatives. The project team may need to incorporate additional requirements as laboratory and support spaces are more definitively outlined.

Division 7: Project Cost Estimate

Phase 1 – Estimated Project Cost

A. Construction Total		\$63,490,080
General Construction	\$205.20/SF	36,894,960
Demolition	\$0/SF	0
Plumbing Construction	\$31.35/SF	5,636,730
Fire Protection Construction	\$3.99/SF	717,400
HVAC Construction	\$54.72/SF	9,838,660
Electrical Construction	\$33.92/SF	6,097,920
Telecommunications	\$4.56/SF	819,890
Audio/Visual Equipment	\$11.40/SF	2,049,720
DDC	\$7.98/SF	1,434,800
B. Hazardous Materials Abatement		\$0
C. Design & Supervision Total		\$12,830,510
DSF Management Fee (4% of Construction Total)		2,539,600
A/E Fees (7% of Construction Total)		4,444,300
Project Contingency (8% of Construction Total)		5,079,210
Commissioning (1% of Construction Total)		634,900
Other Prime Consultants (Abatement)		0
Other Prime Consultants (Audio/Visual – Allowance)		100,000
Geotechnical Investigation (Allowance)		10,000
Site Survey		7,500
Plan Review Fees		15,000
D. Equipment		\$3,131,510
Furnishings		1,339,510
Movable Laboratory Equipment		1,792,000
E. Percent for Art		\$0
F. Total Estimated Project Cost		\$79,452,100

Notes:

1. UW-La Crosse has identified seven laboratory spaces that are to be included in Phase 1 if budget allows.
2. UW-La Crosse has identified a need for unfinished basement space for storage and is to be included in Phase 1 if budget allows.
3. Phase 1 Construction Cost Estimate adjusted to construction start date of 2015.

Division 7: Project Cost Estimate

Phase 2 – Estimated Project Cost (New Facility)

A. Construction Total		\$43,522,780
General Construction	\$190.50/SF	28,141,040
Demolition	\$7.49/SF	1,348,740
Plumbing Construction	\$10.16/SF	1,500,860
Fire Protection Construction	\$3.56/SF	525,300
HVAC Construction	\$27.94/SF	4,127,350
Electrical Construction	\$31.75/SF	4,690,170
Telecommunications	\$5.08/SF	750,430
Audio/Visual Equipment	\$11.94/SF	1,876,070
DDC	\$3.81/SF	562,820
B. Hazardous Materials Abatement		\$250,000
C. Design & Supervision Total		\$8,944,560
DSF Management Fee (4% of Construction Total)		1,740,910
A/E Fees (7% of Construction Total)		3,046,600
Project Contingency (8% of Construction Total)		3,481,820
Commissioning (1% of Construction Total)		435,230
Other Prime Consultants (Abatement)		75,000
Other Prime Consultants (Audio/Visual – Allowance)		150,000
Geotechnical Investigation (Allowance)		0
Site Survey		0
Plan Review Fees		15,000
D. Equipment		\$2,269,010
Furnishings		1,678,120
Movable Laboratory Equipment		590,890
E. Percent for Art		\$0
F. Total Estimated Project Cost		\$54,986,350

Notes:

1. UW-La Crosse has identified seven laboratory spaces that are to be included in Phase 1 if budget allows.
2. UW-La Crosse has identified a need for unfinished basement space for storage and is to be included in Phase 2 if budget allows.
3. Phase 2 Construction Cost Estimate adjusted to construction start date of 2017.

Division 7: Project Cost Estimate

Phase 2 – Estimated Project Cost (Renovation and New Addition)

A. Construction Total		\$47,659,950
	Construction Total (New Addition)	\$22,865,800
	General Construction	\$190.50/SF 14,504,670
	Demolition	\$12.00/SF 1,128,140
	Plumbing Construction	\$10.16/SF 773,580
	Fire Protection Construction	\$3.56/SF 270,750
	HVAC Construction	\$27.94/SF 2,127,350
	Electrical Construction	\$31.75/SF 2,417,450
	Telecommunications	\$5.08/SF 386,790
	Audio/Visual Equipment	\$12.70/SF 966,980
	DDC	\$3.81/SF 290,090
	Construction Total (Renovation)	\$24,794,140
	General Construction	\$180.34/SF 14,950,190
	Demolition	\$12.00/SF 0
	Plumbing Construction	\$13.34/SF 1,105,470
	Fire Protection Construction	\$5.72/SF 473,770
	HVAC Construction	\$34.93/SF 2,895,280
	Electrical Construction	\$39.37/SF 3,263,770
	Telecommunications	\$6.35/SF 526,420
	Audio/Visual Equipment	\$11.00/SF 1,158,110
	DDC	\$5.08/SF 421,130
B. Hazardous Materials Abatement		\$250,000
C. Design & Supervision Total		\$9,772,000
	DSF Management Fee (4% of Construction Total)	1,906,400
	A/E Fees (7% of Construction Total)	3,336,200
	Project Contingency (8% of Construction Total)	3,812,800
	Commissioning (1% of Construction Total)	476,600
	Other Prime Consultants (Abatement)	75,000
	Other Prime Consultants (Audio/Visual – Allowance)	150,000
	Geotechnical Investigation (Allowance)	0
	Site Survey	0
	Plan Review Fees	15,000
D. Equipment		\$2,442,850
	Furnishings	1,806,690
	Movable Laboratory Equipment	636,160
E. Percent for Art		\$0
F. Total Estimated Project Cost		\$60,124,800

Notes:

1. UW-La Crosse has identified seven laboratory spaces that are to be included in Phase 1 if budget allows.
2. UW-La Crosse has identified a need for unfinished basement space for storage and is to be included in Phase 2 if budget allows.
3. Phase 2 Construction Cost Estimate adjusted to construction start date of 2017.

Division 7: Project Cost Estimate

This page intentionally left blank

Division 8: Project Schedule

TASK/ACTIVITY	DATE
Begin Pre-Design Study	March 2010
Draft Program Statement and Pre-Design Study Complete	May 2011
Final Program Statement and Pre-Design Study Complete	August 2011
Phase 1 Project Schedule	
A/E Selection for Building Design	September 2013
A/E Begins Design Work	October 2013
35% Design Report Complete	March 2014
Approval to Construct by Board of Regents/State Building Commission	April 2014
Construction Documents Complete	December 2014
Project Bidding	February 2015
Construction Starts	April 2015
Substantial Completion	May 2017
Students & Faculty Occupy Building	Fall 2017
Phase 2 Project Schedule	
A/E Selection for Building Design	TBD
A/E Begins Design Work	TBD
35% Design Report Complete	TBD
Approval to Construct by Board of Regents/State Building Commission	TBD
Construction Documents Complete	TBD
Project Bidding	TBD
Construction Starts	TBD
Substantial Completion	TBD
Students & Faculty Occupy Building	TBD

Division 8: Project Schedule

This page intentionally left blank